



This page intentionally left blank.

PhonePad 5 User Guide

by Cybercom Software

PhonePad 5 User Guide

Copyright © 2026 Cybercom Software

All rights reserved. No parts of this work may be reproduced in any form or by any means - graphic, electronic, or mechanical, including photocopying, recording, taping, or information storage and retrieval systems - without the written permission of the publisher.

Products that are referred to in this document may be either trademarks and/or registered trademarks of the respective owners. The publisher and the author make no claim to these trademarks.

While every precaution has been taken in the preparation of this document, the publisher and the author assume no responsibility for errors or omissions, or for damages resulting from the use of information contained in this document or from the use of programs and source code that may accompany it. In no event shall the publisher and the author be liable for any loss of profit or any other commercial damage caused or alleged to have been caused directly or indirectly by this document.

Printed: May 2026.

Please report any errors or omissions to support@cybercom-software.com.

Table of Contents

Foreword	0
Chapter 1 - Introduction	13
Chapter 2 - Getting Started	15
1 Setting Up the Connection to the Server	16
Connection Troubleshooter	16
What to Do if PhonePad Can't Find the Server	18
2 Starting PhonePad	20
3 Version Mismatch	21
What Can Cause a Version Mismatch?	22
4 Trial Period	23
5 Logging In	24
6 Splash Screen	25
7 Welcome Screen	25
8 Tip of the Day	26
9 User Interface	27
Toolbar	28
Home Tab	28
Folders Tab	29
Follow Up Tab	30
Settings Tab	31
Help Tab	31
Menus	32
File Menu	33
Tools Menu	35
View Menu	37
Help Menu	38
Inbox	40
Folder Tree	41
User List	43
Status Bar	44
Message Lists	45
Message List Columns.....	45
Changing the Order of Columns.....	47
Changing the Width of Columns.....	47
Selecting Which Columns to Display.....	48
Color Coding	50
Search Bar	51
Information Panel	52
Follow Up Notes	53
Caller Information	53
Message Preview	53
Splitters	54
Guided User Interface Help	55

10	User Interface Modes.....	57
11	Configuring the Toolbars.....	58
12	Message Notification Service Error.....	59

Chapter 3 - Messages 63

1	Phone Messages (Incoming).....	64
	Logging an Incoming Call	68
	Message Date and Time.....	69
	Recipients	70
	Caller's Name	71
	Adding a New Caller with Additional Details.....	73
	Editing an Existing Caller	76
	Phone Number	77
	Company	79
	Category	80
	Message Details	80
	Subject	82
	Reference	82
	Attachments	82
	Message Text	83
	Options Button	85
	Sending the Message.....	86
2	Phone Messages (Outgoing).....	86
	Logging an Outgoing Call	88
	Message Date and Time.....	88
	Recipients Name	89
	Company	91
	Phone Number	91
	Notes	92
	Category	94
	Subject	94
	Reference	94
	Message Options	95
	Attachments	95
	Message Text	96
	Saving the Message	97
3	Text Messages.....	97
	Creating a Text Message	99
	Message Date and Time.....	99
	Recipients	100
	Category	102
	Subject	103
	Attachments	103
	Message Options	104
	Message Text	105
	Sending the Message.....	105
4	Viewing Messages.....	106
	Viewing Phone Messages (Incoming)	106
	Viewing Phone Messages (Outgoing)	108
	Viewing Text Messages	110
	Viewing Message Read Receipts	111

Viewing Email Replies	111
Viewing Email Read Receipts	112
Viewing Email Delivery Failure Messages	113
Viewing Attachments	115
5 Forwarding Messages.....	116
6 Replying to Messages.....	116
7 Resending Messages.....	117
8 Moving Messages to Another User's Inbox.....	117
9 Message History.....	118
10 Editing Received or Sent Messages.....	119
11 Deleting Messages.....	120
12 CallFlow.....	121
13 Printing Messages.....	122
Print Messages	122
Printing Options	124
Example Printouts	126
Quick Print	131
Print Message List	131
14 Emailing Messages.....	132
Email Message Settings	133
15 Smart Assistance.....	137

Chapter 4 - Short Messages 141

1 Pushover Messages.....	142
Sending a Pushover Message	144
2 SMS Messages.....	145
Sending an SMS Message	146

Chapter 5 - Folders 149

1 Inbox.....	150
Message Filtering	152
2 Outgoing Folder.....	154
3 Sent Folder.....	155
4 Deleted Folder.....	156
5 Personal Folders.....	158
Adding a Personal Folder	158
Editing a Personal Folder	159
Deleting a Personal Folder	159
Emptying a Personal Folder	160
Accessing a Personal Folder	160
Changing a Personal Folder to a Public Folder	161
6 Public Folders.....	162
Adding a Public Folder	163
Editing a Public Folder	163
Deleting a Public Folder	164
Emptying a Public Folder	165

- Accessing a Public Folder 165
- Changing a Public Folder to a Personal Folder 166
- 7 Group Folders..... 167**
 - Adding a Group Folder 168
 - Editing a Group Folder 169
 - Deleting a Group Folder 169
 - Emptying a Group Folder 170
 - Accessing a Group Folder 170
- 8 Sub-Folders..... 171**
 - Adding a Sub-Folder 172
 - Editing a Sub-Folder 173
- 9 Undeleted Folder..... 173**
- 10 Moving Messages..... 174**
- 11 Moving Folders..... 176**
- 12 Folder Message Counts..... 176**
- 13 Searching Folders..... 178**
- 14 Navigation Bar..... 179**

Chapter 6 - Following Up 181

- 1 Mark Messages for Follow Up..... 182**
- 2 Mark Follow Ups as Completed..... 183**
- 3 Unmarking a Message for Follow Up..... 184**
- 4 Automatically Marking Messages for Follow Up..... 184**
- 5 Follow Up Notes..... 184**
 - Add a Follow Up Note 184
 - Edit a Follow Up Note 185
 - Delete a Follow Up Note 186
 - View a Follow Up Note 187
 - Printing Follow Up Notes 187
- 6 Reminders..... 188**
 - Adding a Reminder 188
 - Editing a Reminder 189
 - Viewing Due Reminders 190
 - Managing Reminders 191
 - Reminder Alerts 193

Chapter 7 - Caller ID 195

- 1 CallerID.com..... 196**
 - How It Works 197
 - Installing the Caller ID Service 198
 - Configuring CallerID.com 198
 - Caller Information 199
 - Call History 200
 - History List 201
 - History Graph 202
- 2 TAPI..... 203**
 - How It Works 203

Configuring TAPI	204
Caller Information	205
Received Calls	206
Dialling a Number	206
Dialling a Number from the Inbox.....	206
Dialling a Number from Received Calls.....	207
Chapter 8 - Global Searching	209
Chapter 9 - Passwords	213
1 Changing Your PhonePad Password.....	214
Chapter 10 - Preferences	215
1 General.....	216
2 Startup.....	219
3 Notifications.....	222
4 Messages - 1.....	225
5 Messages - 2.....	227
6 Messages - 3.....	228
7 Messages - 4.....	230
8 Messages - 5.....	232
9 Follow Up.....	233
10 Reminders.....	234
11 Address Book.....	236
12 Telephone Setup.....	238
13 Short Messaging.....	239
Pushover Messages	239
SMS Messages	240
14 Message Alert.....	241
15 Voice Announcements.....	243
16 Appointment Calendar.....	244
Chapter 11 - Automatic Message Forwarding	247
1 Forward to Other PhonePad Users.....	248
2 Forward Via Email.....	250
3 Forward Via SMS.....	252
4 Forward Via Pushover.....	254
5 Availability Settings.....	256
6 Important Information About Automatically Forwarded Emails.....	257
Chapter 12 - Address Book	259
1 Address Tabs.....	261
2 Add an Address Book Entry.....	262

3	Edit an Address Book Entry	273
4	Delete an Address Book Entry	273
5	View an Address Book Entry	273
6	Print Address Book Entries	273
7	Importing Your Contacts	273
8	Exporting Your Contacts	276
9	Deleting All Entries	276
10	Setting the Columns	277
11	Address Book Settings	277
12	Searching	277
13	Documents	279
	Adding a Document	280
	Editing a Document	281
	Deleting a Document	282
	Opening a Document	282
	Saving a Document	282
	Searching for Documents	283
14	Close the Address Book	284
Chapter 13 - System Information		285
Chapter 14 - Control Bar		287
1	Control Bar Settings	289
2	Launching ControlBar	293
Chapter 15 - Shortcuts		295
Chapter 16 - Instant Chat		297
1	Starting a Chat	298
2	Receiving a New Chat	300
3	Ending a Chat	300
4	Settings	301
5	Closing Instant Chat	302
Chapter 17 - Message Alert		305
1	Menu	306
2	Setting Up Message Alert	307
	Select the Inboxes You Want to Monitor	308
	Set the Message Checking Frequency	309
	Set the Notification Display	309
	Save Your Settings	309
3	Using Message Alert	310
4	Starting and Stopping Message Alert Automatically	310

Chapter 18 - ToDo List	311
Chapter 19 - WhereRU	313
1 User Interface	314
Main Window	314
Toolbar	315
Menus	316
File Menu	316
Tools Menu	317
Help Menu	317
2 Setting Your Status	317
3 Setting a Return Time	318
Clearing a Return Time	319
4 Setting Status Text	319
5 Comments	320
6 Resetting Your Status	320
7 User Details	321
8 Maintain Status Text	321
9 Sorting the User List	322
10 Automatic Message Forwarding	323
Chapter 20 - WorkstationConfig	325
Chapter 21 - Workstation Service Center	333
Chapter 22 - Example Scenarios	335
1 Setting Up a Common Inbox	336
A. Disabled User Account	336
B. Group Inbox	338
2 PhonePad for Answering Services	339
Chapter 23 - Connecting Remotely Over the Internet	341
Chapter 24 - Updating PhonePad	345
1 How Updating Works	347
2 Installing Server Updates	348
3 Updating PhonePad from My PhonePad	349
4 Update Notifications	350
Chapter 25 - Troubleshooting Problems	351
1 Startup Problems	352
Login Validation Error	352
Windows Startup	353
Freezing on Startup	355

2	Connection Issues.....	356
3	I/O Error 103.....	357
4	Checking Windows Permissions.....	359
5	Speed Issues.....	359
	Anti-Virus and Anti-Spyware Software	360
	Network Connectivity	360
	High Network Traffic	361
	Heavy Server Load	361
	Chapter 26 - Connection Issues	363
	Chapter 27 - Support	367
	Chapter 28 - Update Plan	369
1	Renewing Your Update Plan.....	371
2	Refreshing Your Update Plan.....	373
	Index	375

Chapter

1

Introduction

Introduction

Welcome to PhonePad 5.

If you're new to PhonePad we recommend you start with the Getting Started section.

A massive amount of work has gone into producing this version. In fact, it's the biggest update to PhonePad in years. It features a new, high performance database engine that allows us to do things that weren't possible in previous versions.

PhonePad 5 uses a completely different method for connecting. Instead of having to manually configure each workstation to connect to the PhonePad database it's now all done automatically.

We have incorporated a lot of changes and new features based on feedback from our wonderful customers. PhonePad is a continually evolving product that is shaped by people like you. We truly value your suggestions and look forward to receiving more of them.

We hope you enjoy using PhonePad 5 and find it a valuable tool for your business or organization.

Cybercom Software



While all due care is taken in the writing of this user guide, it's possible that there are errors because we have overlooked something.

If you find that there is missing, incorrect, incomplete, or out-of-date information, please contact us and let us know. We'll do our best to get it corrected quickly.

Just send an email along with the details to support@cybercom-software.com.

Thanks.

Chapter

2

Getting Started

Getting Started

Follow the steps in this chapter to get PhonePad 5 up and running.

Setting Up the Connection to the Server

You may be pleased to know that once you have installed PhonePad 5 on your workstation there is nothing else you need to do. You don't need to configure PhonePad to connect to the Server or Host PC.

When PhonePad starts up it will try to auto-discover any PhonePad 5 Servers on your network. Your workstations will automatically establish a connection with the server once it finds it.

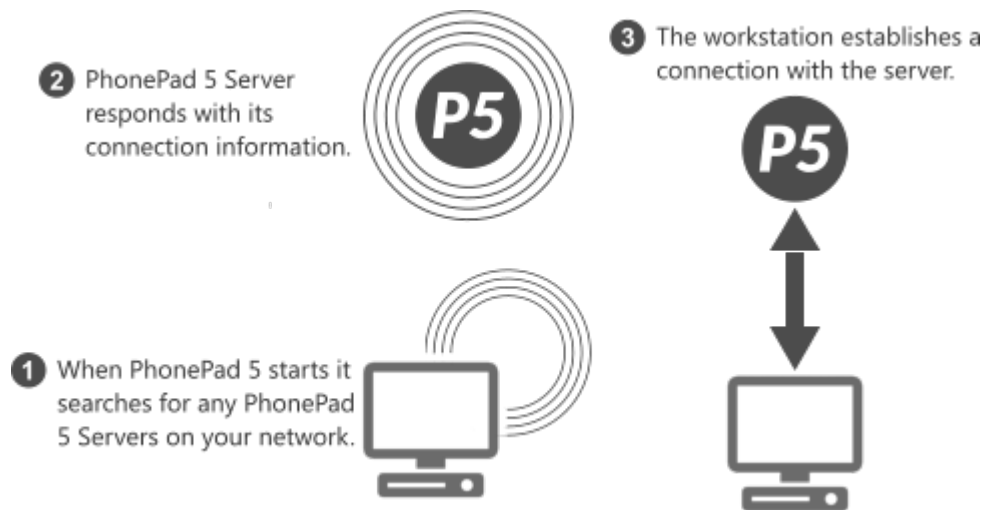

If PhonePad is unable to connect to the PhonePad 5 Server then it will be due to one of the following reasons:

- The PhonePad 5 Server service has not been installed or is not running.
- A firewall, and/or security software, on the Server or Host PC, or on the workstation is blocking the connection. You may need to configure it to allow the connection.

Connection Troubleshooter

If PhonePad is unable to locate the PhonePad 5 Server, or if it is able to locate it but is unable to connect, then the **Connection Troubleshooter** wizard will automatically open.



The wizard will try to help you determine what is causing the connection issues. In most cases it is Anti-Virus software

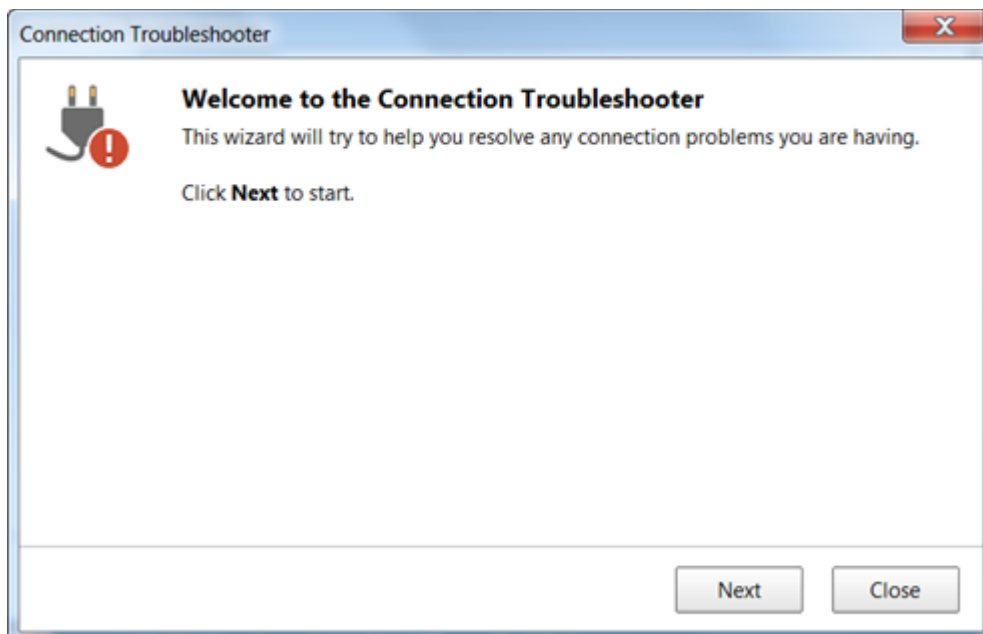

Step through each screen by clicking the **Next** button, and try each of the suggestions.

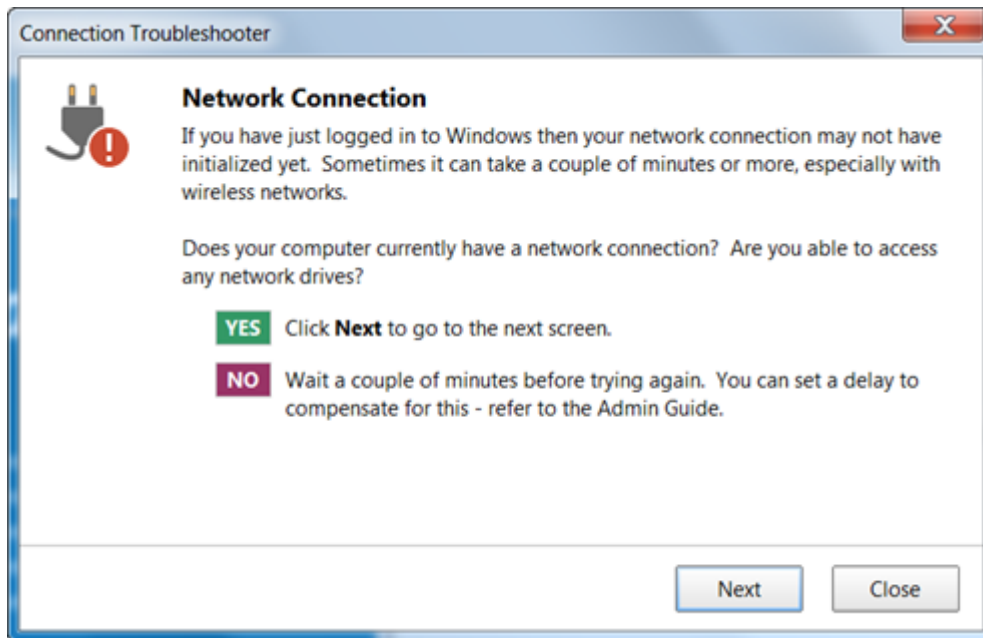

What to Do if PhonePad Can't Find the Server

If you have tried everything and still can't find out what is blocking PhonePad's automatic connection system, then you can override the server auto-discovery system by manually specifying the server settings.

1. Run the **Workstation Configuration** application (WorkstationConfig.exe) - it's located in the PhonePad 5 folder on each workstation.

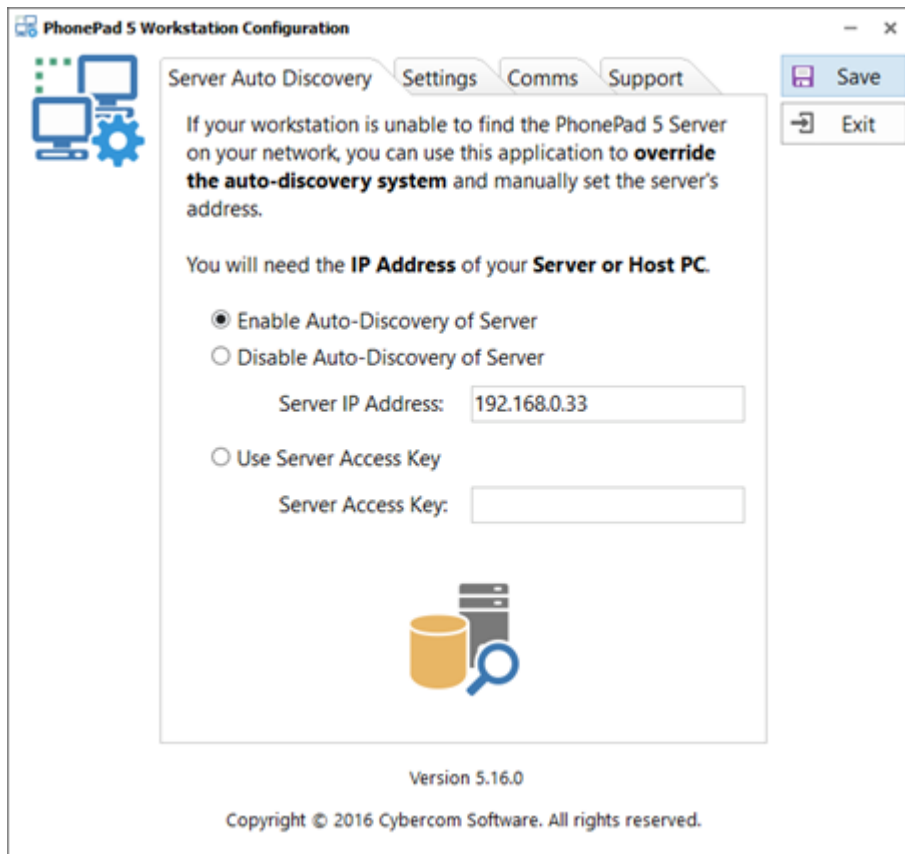

2. Select **Disable Auto-Discovery of Server**.
3. Enter the Server's IP Address.
4. Click **Save**.
5. Click **Exit**.
6. Try starting PhonePad again. You should now be able to connect to the Server or Host PC.

 Using the ServerOverride setting will disable the automatic connection system so any changes to the Server IP Address will not be detected.

Starting PhonePad

Double-click the PhonePad 5 icon to start PhonePad.



PhonePad will auto-discover any PhonePad 5 Servers on the network and establish a connection.

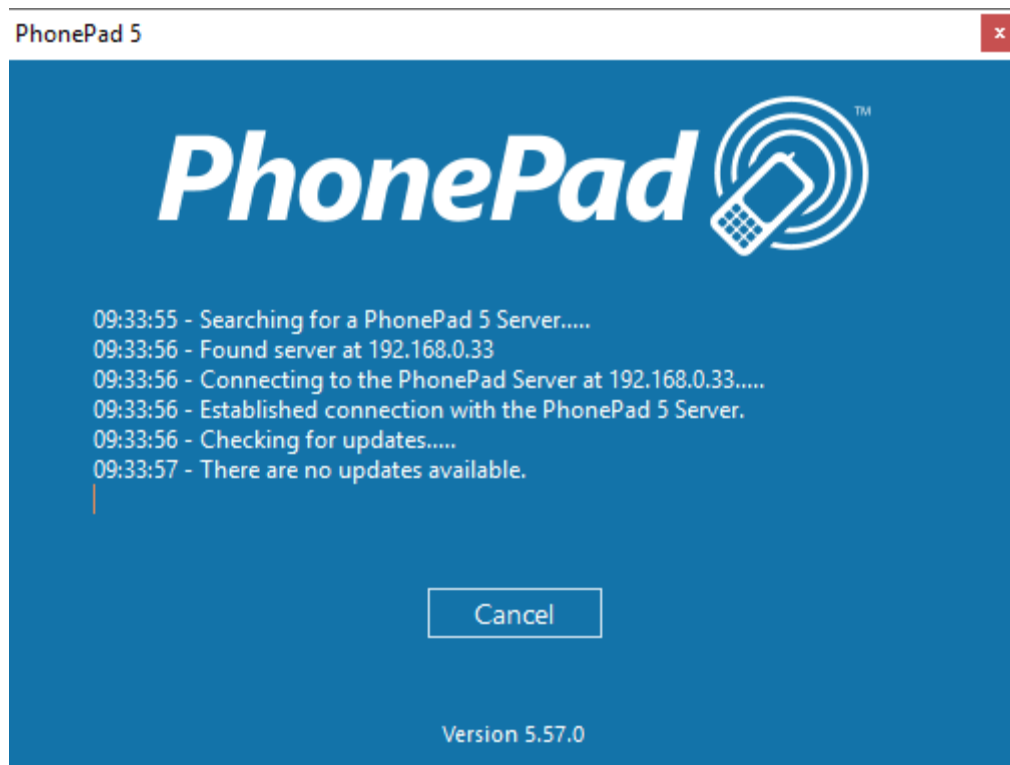

It will then check for any workstation updates and install them if they are found.

The version number for the installed version of PhonePad is displayed at the bottom of this screen.

Version Mismatch

The PhonePad 5 Workstation and PhonePad 5 Server software should always be the same version. If they're not then PhonePad may not function correctly.

Normally you shouldn't have to worry about this as the PhonePad 5 Server should keep the versions on the workstations and Server/Host PC synchronized.

To avoid problems, PhonePad will check both version numbers on start up. If there is a version mismatch then an error message will be displayed.

Older Version on Workstation

If the workstation version is *older* than the Server/Host PC version then this message will be displayed:

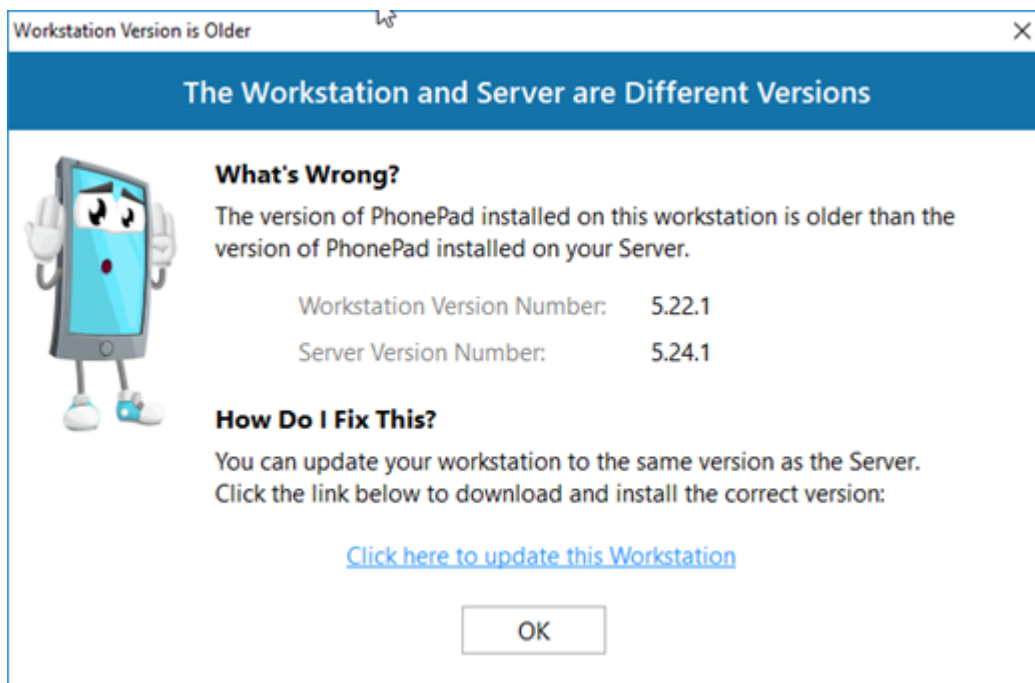

This can be easily resolved by clicking on the link in the message. PhonePad will automatically download the correct version for the workstation.

Newer Version on Workstation

If the version on the workstation is *newer* than the Server/Host PC then this version will be displayed:

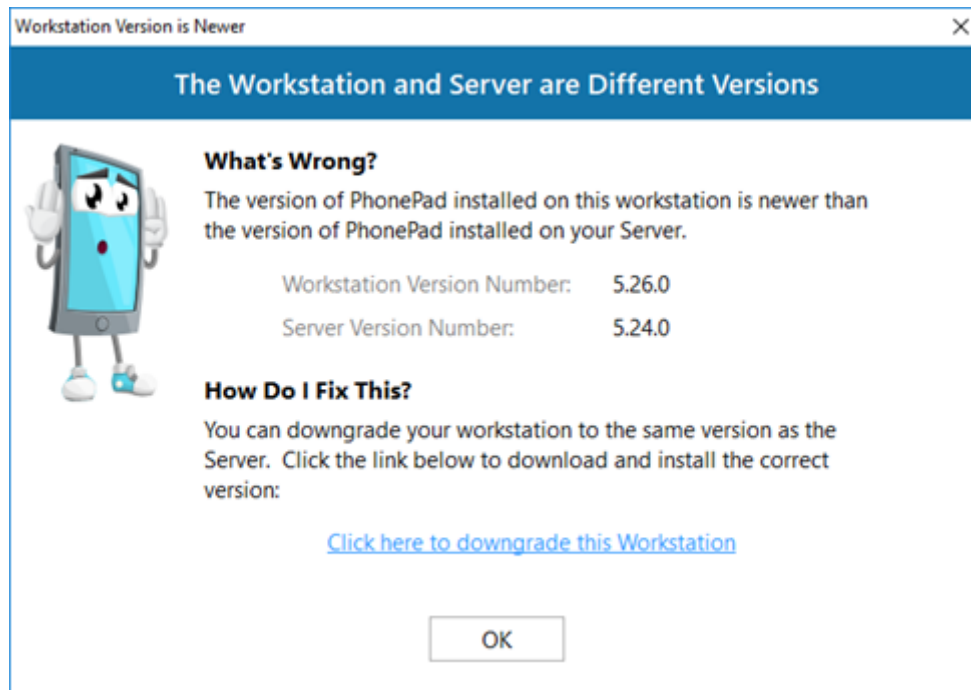

This would only happen if the wrong version of PhonePad 5 Workstation was manually downloaded and installed on the workstation. For example, if you added a new computer to your network you may have accidentally downloaded the latest version of the workstation software from the website instead of downloading the version installed on all other workstations.

This can be quickly fixed by clicking the provided link to download and install the correct version.

What Can Cause a Version Mismatch?

The most common cause of a version mismatch between the PhonePad 5 Workstation software and the PhonePad 5 Server software is this scenario:

- PhonePad 5 is already up and running on a network and a new computer is installed. PhonePad 5 Workstation is downloaded from the website and installed on the new computer, but the version downloaded is a more recent version.

There are 3 ways to avoid this scenario:

1. Retain a copy of the original Workstation setup program you downloaded when you installed PhonePad. Use this copy to install PhonePad 5 Workstation on all new computers.
2. Install PhonePad 5 Server Updates whenever they are released.
3. Keep your system up-to-date with the latest releases by setting up automatic updates.

Another far less likely cause is that the automatic workstation updates done by the PhonePad 5 Server have failed for some reason. This can happen if the workstation has insufficient access rights for the PhonePad 5 folder.

Trial Period

If you are using PhonePad during the trial period you will see the trial screen appear when PhonePad starts up.



The image shows a trial screen for PhonePad 5. On the left is a cartoon character of a blue smartphone with a smiling face, arms, and legs. To the right of the character is the PhonePad logo, which consists of the word "PhonePad" in a bold, sans-serif font and a blue circular icon with a white smartphone inside, emitting signal waves. Below the logo, the text reads: "Thank you for trying PhonePad 5. You can try PhonePad for 60 days free of charge. Once the trial period has expired, you will need to purchase PhonePad to continue using it. There is no need to reinstall PhonePad after purchasing a license. We have been in business since 1995 and we are here to help any way we can. For more information about PhonePad, please contact us or visit our website." Below this text are contact details: Website: www.phonepad5.com, Email: sales@cybercom-software.com and support@cybercom-software.com, Telephone: 1-866-806-2144 (Toll Free in US and Canada) and 1800-856-453 (Toll free in Australia). At the bottom, there is a bold statement: "You have 60 days left of your 60-day trial." Below this statement are five buttons: "Continue Trial" (with a play button icon), "Buy Now" (with a shopping cart icon), "License" (with a key icon), "Extend Trial" (with a refresh icon), and "Exit" (with a square icon).

PhonePad

Thank you for trying PhonePad 5. You can try PhonePad for 60 days free of charge.

Once the trial period has expired, you will need to purchase PhonePad to continue using it. There is no need to reinstall PhonePad after purchasing a license.

We have been in business since 1995 and we are here to help any way we can.

For more information about PhonePad, please contact us or visit our website.

Website: www.phonepad5.com

Email: sales@cybercom-software.com
support@cybercom-software.com

Telephone: 1-866-806-2144 (Toll Free in US and Canada)
1800-856-453 (Toll free in Australia)

You have 60 days left of your 60-day trial.

[Continue Trial](#) [Buy Now](#) [License](#) [Extend Trial](#) [Exit](#)

The number of days left of your trial will be displayed on this screen.

Click the **Continue Trial** button to continue using PhonePad.

Click **Purchase** to buy PhonePad.

Click **License** to change your trial version into a fully licensed version. Once this has been done the trial screen will no longer appear.

Click **Extend Trial** if your trial period is almost over and you need more time to evaluate. This will extend the trial by another 60 days, and you can use it twice (giving you a total of 180 days). **Please note:** this button only becomes enabled a couple of days before your trial ends.

Click **Exit** to close PhonePad.

Logging In

The login dialog is displayed when PhonePad starts up.

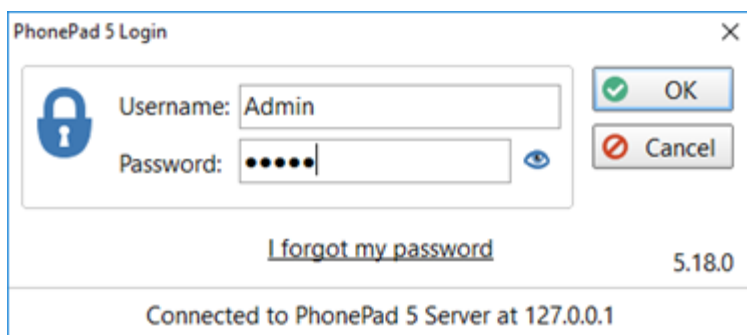

Enter the **username** and **password** provided to you by your PhonePad administrator.

The **username** is *not* case-sensitive but the **password** is. Make sure **CAPS LOCK** is **not** on.

Once you have typed in your user name and password, click **OK** to continue the login process. You will be given *three attempts* to login. After a third unsuccessful attempt PhonePad will automatically shut down.

If you click on the "eye" icon and hold down your mouse button, it will reveal the password you entered. You can use this to verify that you entered your password correctly.

If you have forgotten your password, you can click the **I forgot my password** link to have your password sent to your email address or cell/mobile phone (this feature has to be enabled by your PhonePad administrator).

The login dialog also shows the version number of PhonePad you are using (in this example it is 5.18.0), and the PhonePad Server you are connected to.

Splash Screen

The splash screen will be displayed while PhonePad 5 is loading and will automatically close when it has finished.



If you get an error message when PhonePad is loading (or suspect there might be one) but you can't see it because it's being obscured by the splash screen, just **double-click** on the splash screen to close it.

Welcome Screen

After you login, the Welcome window should be displayed (unless the **Show on Startup** check box has been unchecked).

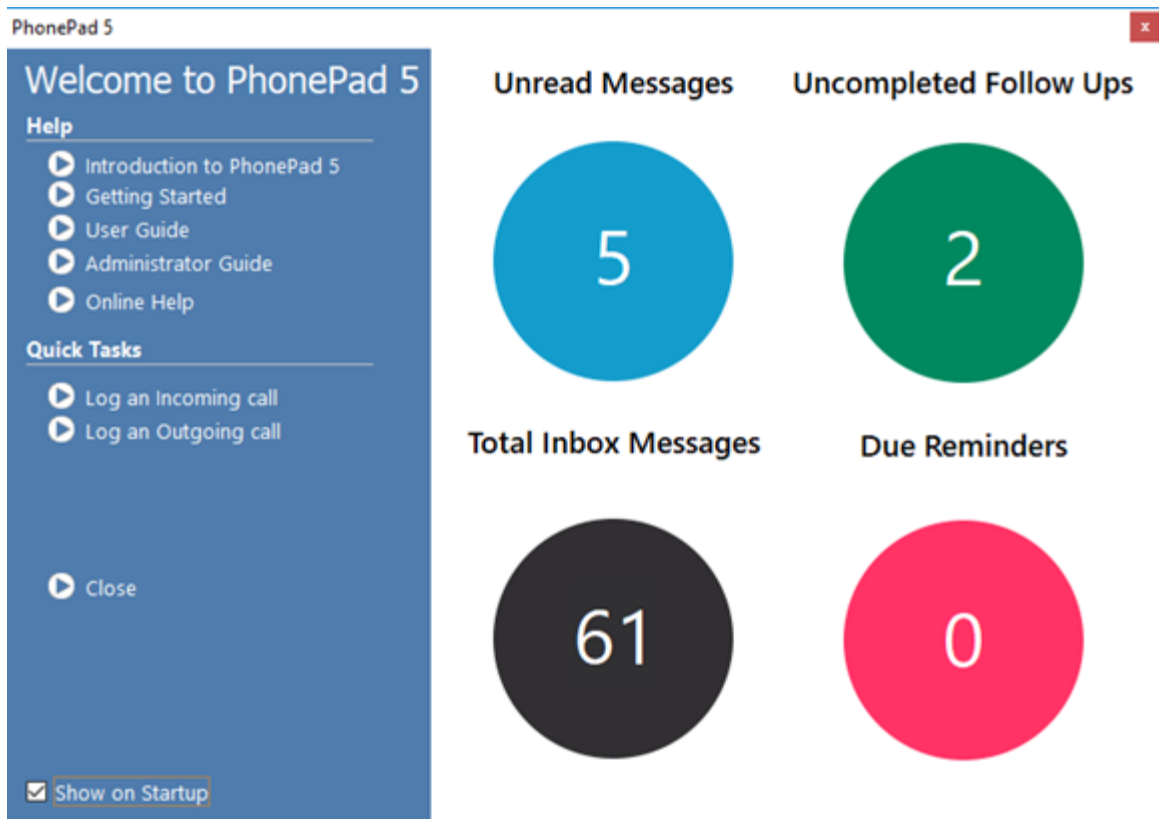

This window has a number of handy links in addition to a graphical overview of the current status of all of your messages.

Tip of the Day

The **Tip of the Day** window will automatically appear after logging in to PhonePad.



A tip is randomly selected and displayed. Tips inform you about many of PhonePad's features and are tell you about things you may not know about your new software.

You can click the **Next Tip** button to randomly display other tips.

The **Close** button will close Tip of the Day.

If you don't want tips being displayed, uncheck the **Show on startup** checkbox *before* clicking **Close**.

You can access Tip of the Day at any time by selecting **Tip of the Day** from the **Help** menu.

User Interface

The main window features menus, a multi-tabbed toolbar, the folder tree, the inbox, follow up notes and the status bar. The window's title bar shows the currently logged-in user.

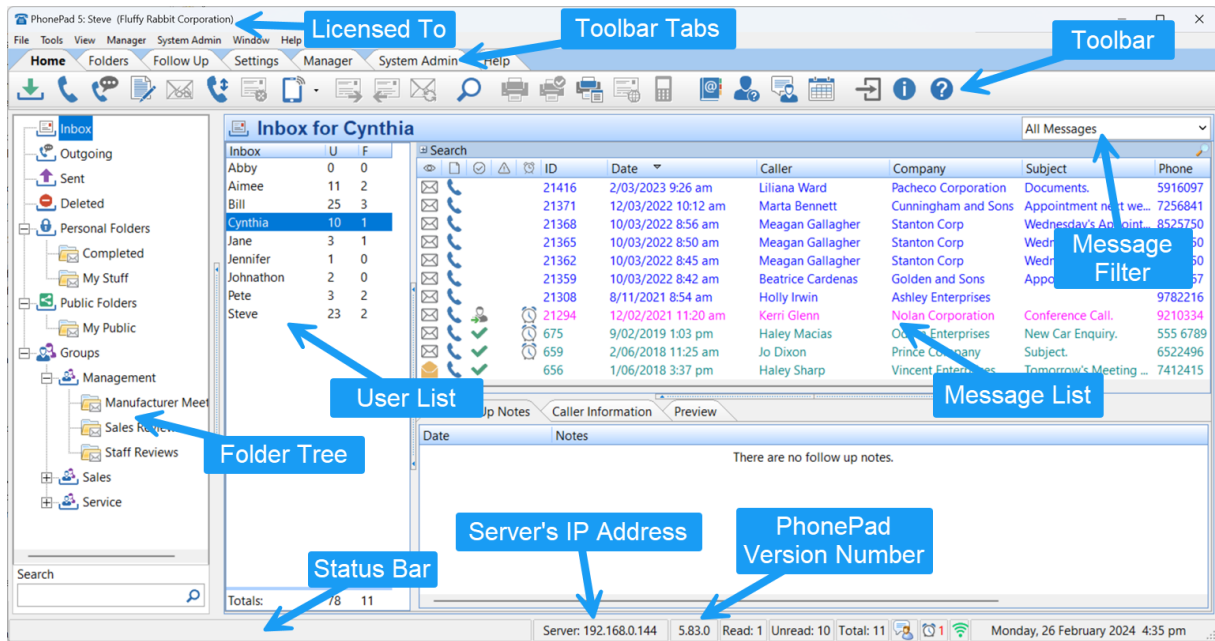

Toolbar

PhonePad 5 features a multi-tab toolbar, organized by functionality. These features can also be accessed via the menus.

Home Tab



1	Check for new messages.
2	Create new incoming phone message.
3	Create new outgoing phone message.
4	Create text message (not to be confused with SMS messages).
5	View message.
6	View CallFlow.
7	Delete message.

8	Short Messages.
9	Forward message.
10	Reply to message.
11	Resend message (only applies to message in the Sent folder).
12	Search for a message.
13	Print message.
14	Quick print message.
15	Print message list.
16	Email selected message.
17	Dial phone number in the selected message (requires TAPI devices).
18	Access the PhonePad Address Book.
29	Open WhereRU, the PhonePad In-Out Board.
20	Open Instant Chat, and instant messaging application included with PhonePad.
21	Appointment Calendar. Open the Appointment Calendar application.
22	Exit PhonePad (also logs out).
23	Show About window.
24	Show online help.

Folders Tab

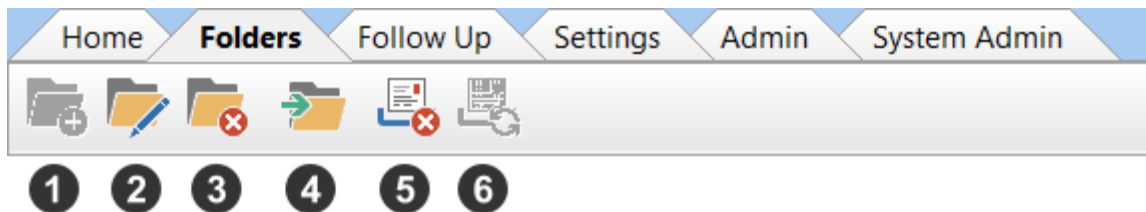

1	Create a new folder.
2	Edit a folder.

3	Delete a folder.
4	Move messages to another folder.
5	Empty a folder.
6	Undelete a message in the Deleted folder.

Follow Up Tab

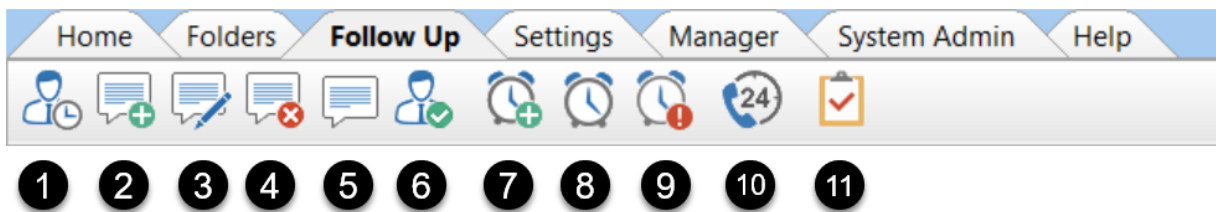

1	Mark/unmark message for Follow Up.
2	Add Follow Up note.
3	Edit Follow Up note.
4	Delete Follow Up note.
5	View Follow Up note.
6	Mark Follow Up as Completed.
7	Add Reminder.
8	Manage Reminders.
9	View Reminders.
10	View Incoming and Outgoing calls captured by Caller ID.
11	Open the To Do List application included with PhonePad.

Settings Tab

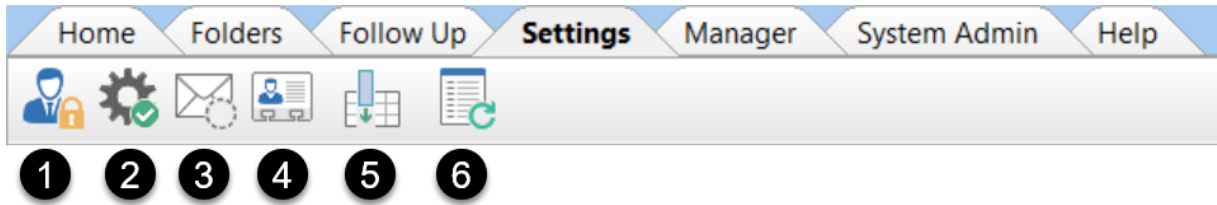

1	Change PhonePad password.
2	User Preferences.
3	Automatic Message Forwarding settings (requires MessageSender 6 to work).
4	Caller ID Settings.
5	Select the columns you want displayed in the selected message list. Each of the message lists can be set independently of each other, eg. Inbox, Sent folder, Outgoing folder, etc.
6	Refresh all lookup lists. The lookup lists are updated regularly but it can sometimes take a little while to propagate to all workstations. You can force the lookup lists to update immediately.

Help Tab

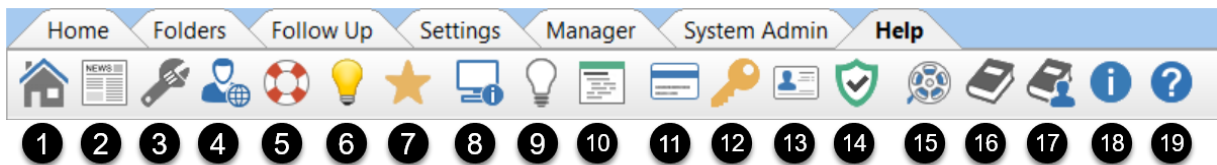

1	Go to PhonePad Home Page.
2	View the Latest News on the Cybercom Software Blog.
3	Access the online support center when you need help with something.
4	Go to your online PhonePad account.
5	Lodge a support request. You can alternatively send an email to support@cybercom-software.com

6	Send us your suggestions. We love getting feedback. Suggestions often lead to valuable new features so have at it.
7	Leave a review of PhonePad and Appointment Calendar. Your review is invaluable in informing and attracting new customers. This helps us stay in business, developing PhonePad and new products we have lined up. Please consider leaving a review. It only takes a couple of minutes.
8	Display important system information. Often needed for support purposes.
9	Show Tip of the Day.
10	View the What's New window.
11	Buy PhonePad 5 if you don't already have a license, or upgrade to another version or edition.
12	Enter your license details to license your copy of PhonePad. This is a system-wide setting so it only needs to be done once.
13	Display your PhonePad license details.
14	Display your current Update Plan details.
15	Go to the Video Tutorials page on our website.
16	View the Admin Guide
17	View the User Guide.
18	Show About window.
19	Show online help.

Menus

PhonePad 5 has 6 menus. Many of the features covered by the menus can also be accessed via the toolbar.

File Menu

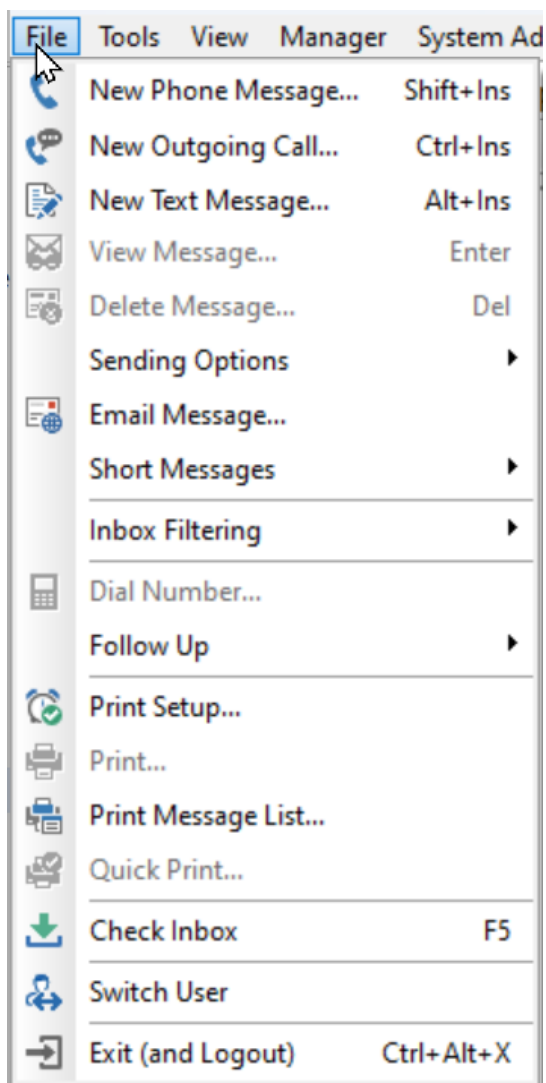

New Phone Message	Open a new phone message for logging an incoming call.
New Outgoing Message	Open a new phone message for logging an outgoing call.
New Text Message	Open a new text message. This is not the same as an SMS text message.
View Message	Open the selected message for viewing.
Delete Message	Delete the selected message. Deleted messages are moved to the Deleted Folder.

Sending Options	Forward, reply to, or resend the selected message.
Email Message	Email the selected message.
Short Messages	Send a quick message via Pushover or SMS.
Inbox Filtering	Filter the messages in the Inbox.
Dial Number	Dial the phone number contained in the selected message, if you have a TAPI compliant device attached.
Follow Up	Mark/unmark a message for Follow Up, or mark a message as completed.
Print Setup	Specify the default printer to use.
Print	Print the selected messages.
Print Message List	Print a list of all messages.
Quick Print	Print the selected messages using a simplified layout.
Check Inbox	Check for any new messages.
Switch User	Click Switch User to logout of PhonePad and login as a different user.
Exit (and Logout)	Log out of PhonePad and close it.

Tools Menu

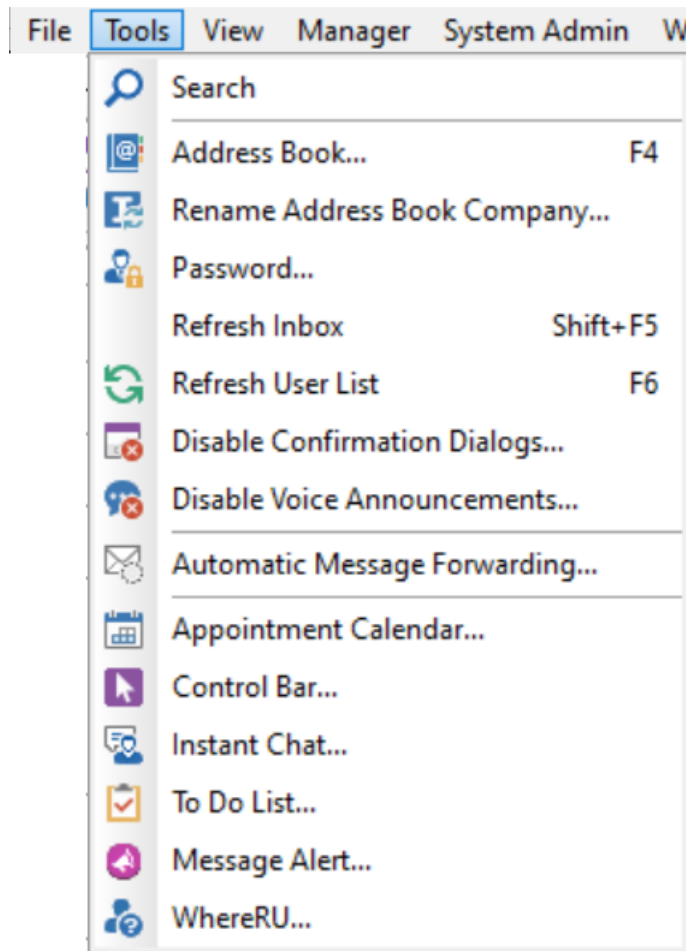

Search	Search for messages by caller, company, phone number, message text and subject.
Address Book	Maintain all of your PhonePad contacts.
Rename Address Book Company	Rename a company wherever it appears in the Address Book.
Password	Change your PhonePad password.
Refresh Inbox	Force update the message list in Inbox.
Refresh User List	Refreshes the user list if it is displayed. The user list is only displayed if you have access to other user's folders.

Disable Confirmation Dialogs	Provides a way to disable all confirmation dialogs at once, instead of disabling them individually in Preferences.
Disable Voice Announcements	Provides a way to disable all voice announcements at once, instead of disabling them individually in Preferences.
Automatic Message Forwarding	Specify your message forwarding settings. Requires MessageSender 6.
Appointment Calendar	Open the PhonePad Appointment Calendar.
Control Bar	This toolbar gives you quick access to common PhonePad features. It runs separately from PhonePad.
Instant Chat	Open InstantChat, the instant messaging application.
To Do List	Open the To Do List application.
Message Alert	If you have access to multiple Inboxes, Message Alert can give you new message notifications for each Inbox.
WhereRU	Open WhereRU, the staff availability application.

View Menu

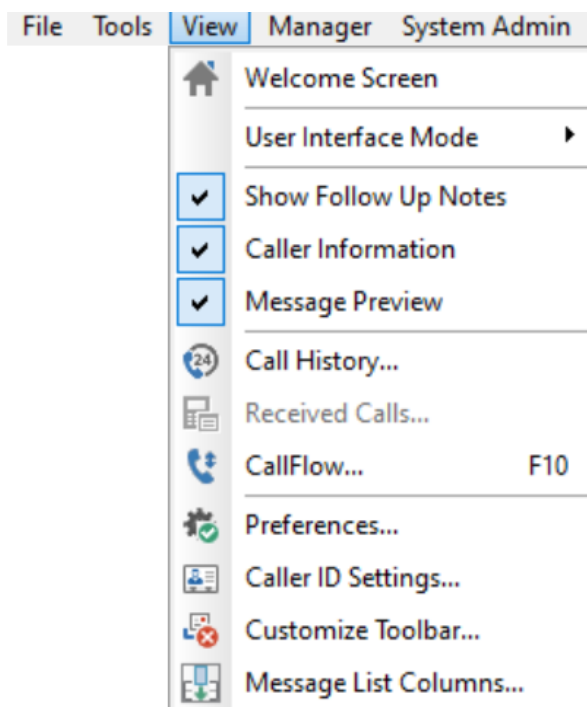

Welcome Screen	Open the Welcome window. This window can be set to display at startup.
User Interface Mode	Select the User Interface Mode most suitable to the way you work: Basic, Standard, Advanced and Custom.
Show Follows Ups	Show/Hide the Follow Ups tab.
Caller Information	Show/hide the Caller Information tab.
Message Preview	Show/hide the Message Preview tab.
Call History	Open the Call History window. If your network has a CallerID.com device connected then this window will show all incoming and outgoing calls.
Received Calls	Open the Received Calls window. If the computer is connected to a TAPI-compliant device then this window will show all phone calls received.
CallFlow	Open the CallFlow window, which displays all messages for the selected caller.
Preferences	Customize your personal settings for various features.

Caller ID Settings	If you have a TAPI-Compliant device or a CallerID.com device, then you can configure PhonePad to use them by selecting this option.
Customize Toolbar	Allows you to show or hide buttons on the various toolbars so that only the buttons you use are displayed.
Message List Columns	Set the columns you want appearing in each folder. Edits the message list in the selected folder.

Help Menu

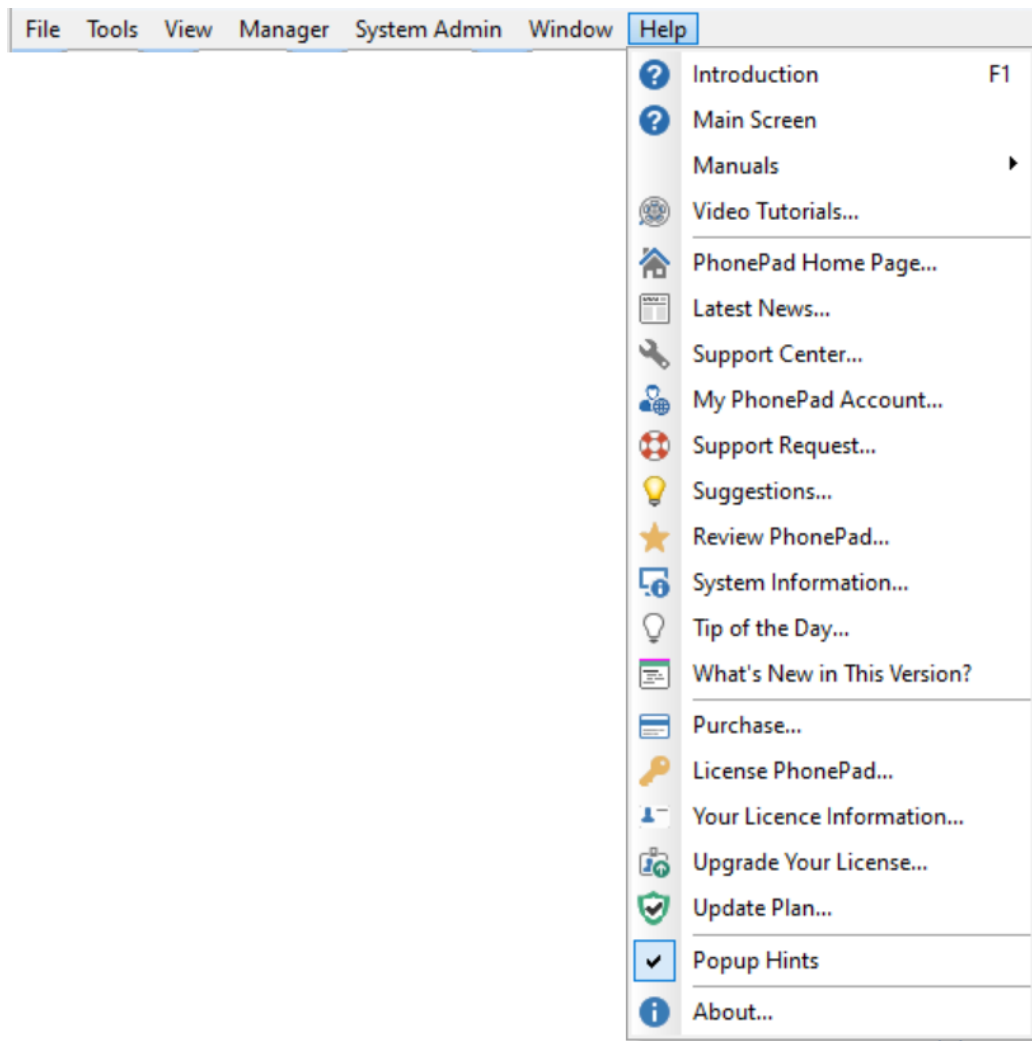

Introduction	Display online help.
---------------------	----------------------

Main Screen	Display an online help topic about PhonePad's main window.
Manuals	Open the User Guide and/or Admin Guide from within PhonePad.
Video Tutorials	Go to the Video Tutorial page on the website.
PhonePad Home Page	Go to the PhonePad home page.
Latest News	View the latest PhonePad news.
Support Center	Access the online support center when you need help with something.
My PhonePad Account	Go to your online PhonePad account (My PhonePad) where you can view your license details, update your contact information, etc.
Support Request	Lodge a support request if you're having problems.
Suggestions	Tell us your suggestions for improving and enhancing PhonePad.
Review PhonePad	Reviews help potential customers make an informed decision about purchasing PhonePad, and help us get more customers so that we can continue to develop it.
System Information	Displays important system information. Often needed for support purposes.
Tip of the Day	Displays random tips designed to help you get the most out of your software.
What's New in This Version	Displays the changes that have been made in the installed version of PhonePad 5.
Purchase	Buy PhonePad 5 if you don't already have a license, or upgrade to another version or edition.
License PhonePad	Enter your license details to license your copy of PhonePad. This is a system-wide setting so it only needs to be done from one workstation.

Upgrade Your License	Upgrade your license to add more users.
Your License Information	Display your PhonePad license details.
Update Plan	Display your current Update Plan details.
Suggestions	Tell us your suggestions for improving and enhancing PhonePad.
Popup Hints	If checked, popup hints will be displayed for toolbar buttons.
About	Display information about PhonePad.

Inbox

The Inbox is where you'll probably spend most of your time in PhonePad. It contains all of the messages you receive.

The screenshot shows the 'Inbox' window with a message list and a detailed view of a message. The message list includes columns for ID, Date, Caller, Company, Subject, and Phone. The detailed view shows the 'Followup Notes' tab with a note for message ID 244, dated 27/10/2015 3:14 pm, with the note 'Called back and left a message.' and the user 'Steve'.

- | | |
|----------|---|
| 1 | Message Filter. Select the filter you want to apply from the drop-down menu. |
| 2 | The Search option allows you to search for messages in your Inbox. Click the small button to open the search feature. |

3	Inbox message list. Like the other folders, the Inbox features a color-coded message list.
4	The Follow Up Notes tab displays all notes for the selected message.
5	The Caller Information tab displays contact information for the caller in the selected message. You can show/hide this tab on the View menu.
6	The Preview tab shows a preview of the selected message. You can show/hide this tab on the View menu.

Folder Tree

The Folder Tree gives you quick and easy access to all of the folders in PhonePad.

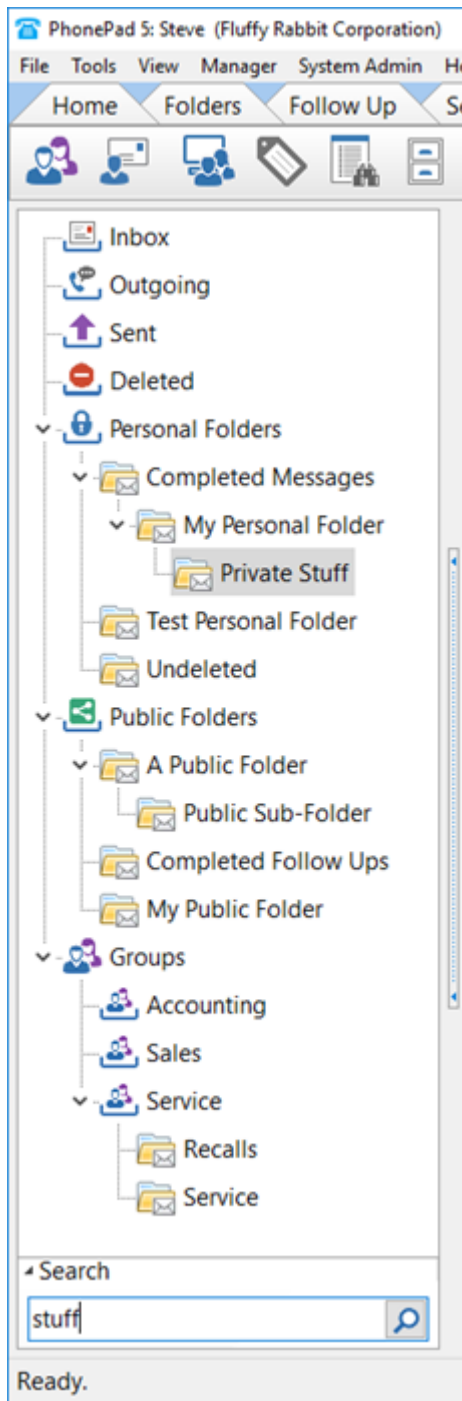

Inbox	The Inbox is the default folder view in PhonePad and it is where you access all of your received messages.
Outgoing	Any outgoing calls you log can be found in the Outgoing folder.

Sent	When you log an incoming call and send the message to other users, PhonePad keeps a copy of these messages in the Sent folder.
Deleted	The Deleted folder is where your messages end up when you delete them. If you need to undelete a message go to this folder. <u>Important:</u> any messages in the Deleted folder are automatically deleted by the system after 14 days.
Personal Folders	The Personal Folders folder is a storage area for any personal folders you have created.
Public Folders	The Public Folders folder is a storage area for any public folders that exist in PhonePad, ie. any public folders created by you or anyone else.
Groups	Groups shows all of the Groups you have been given access to by a PhonePad administrator. Each group will list any Group folders belonging to that group.

User List

If you have been given access to other user's Inboxes by a PhonePad administrator, a user list will appear to the left of your Inbox.

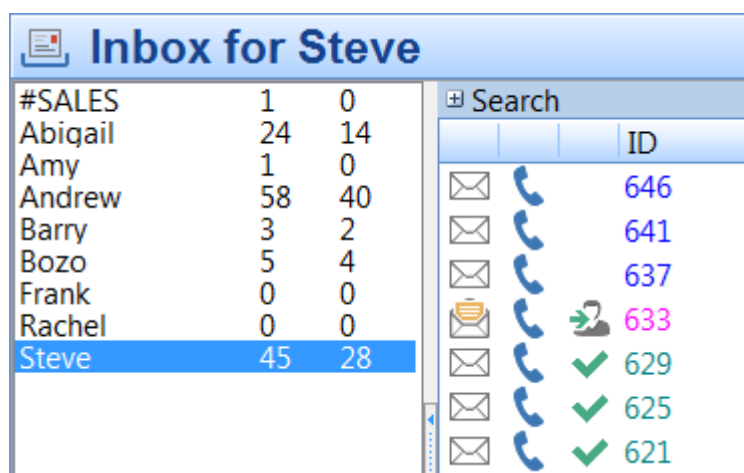

You can access another user's Inbox simply by selecting their name from the user list. You will then be able to access all of the messages in their Inbox.

If you are a member of a group that has an Inbox, you will also be able to access the group inbox. Group Inboxes are always in upper case and are prefixed with a #.

The two columns next to each user's name show the number of unread messages and the number of messages not yet followed up.

Status Bar

The Status Bar sits at the bottom of the PhonePad main window.

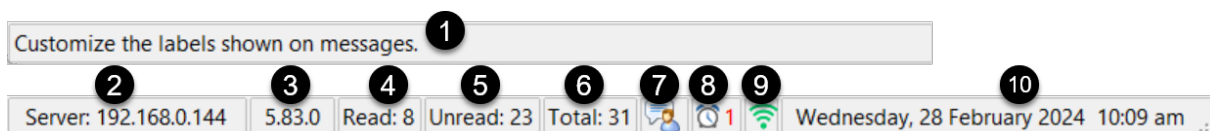

1	The left side of the Status Bar displays extended hints when the mouse is moved over toolbar buttons and menu items.
2	Displays the IP Address of the PhonePad Server you are connected to.
3	Displays the PhonePad Version Number.
4	Shows how many unread messages are in your Inbox.
5	Shows how many read messages are in your Inbox.
6	Shows the total number of messages that are in your Inbox.
7	Click to access Instant Chat.
8	Shows how many due reminders you have. Click to view the due reminders.
9	Status indicator for the PhonePad Workstation Notification Service. This should be green.
10	Shows the current date and time. The format is controlled by System Rules, which is set by a PhonePad administrator.
11	The resize handle allows you to resize the main screen.



If you click on the *Unread Messages*, *Read Messages* or *Total Messages* parts of the **Status Bar** your Inbox messages will be filtered for you.

Message Lists











Every folder in PhonePad has a message list. A message list shows all of your messages contained in that folder.

Search							
	ID	Date	Caller	Company	Subject	Pho...	
	291	21/01/2016 3:59 pm	-----	-----	RE: System Issues.	----	
	288	21/01/2016 9:38 am			fwd: Phone Message.		
	286	21/01/2016 8:17 am	Abby Brock	Mathews Limited	Test	817...	
	282	20/01/2016 9:50 pm			Test Message.		
	280	20/01/2016 8:26 pm	Abby Brock		Urgent Matter.	889...	
	275	20/01/2016 11:17 am	Abby Brock	Mathews Limited	Golf on Thursday?	817...	
	269	8/12/2015 10:20 am	Abby Brock	Mathews Limited	Tuesday Meeting.	817...	
	233	10/11/2015 2:30 pm	-----	-----	RECEIPT: Documents f...	----	
	232	28/10/2015 9:17 am	Lacey Eaton	Schwartz Corp	Returned your call.	750...	
	230	28/10/2015 9:17 am	Gabriela Stark	Clayton and Associates	Appointment.	958...	
	226	27/10/2015 1:32 pm	Abigail Patterson	Fischer Corp	Please call ASAP.	586...	
	222	27/10/2015 1:16 pm	Michael Farmer	Rice Co	Follow Up Meeting.	800...	
	207	29/09/2015 8:40 am	Abby Brock	Mathews Limited	New call from Abby.	817...	
	256	27/09/2015 3:51 pm	Abby Brock	Mathews Limited	Re: Documents	817...	
	251	27/09/2015 3:33 pm	Abby Brock	Mathews Limited	Documents.	817...	

Message List Columns

Message lists are divided into a number of columns:

	<p>The first column shows the read status of a message.</p> <p> The message has not been read.</p> <p> The message has been read.</p> <p> The message has not been read and is urgent.</p>
	<p>The second column indicates the type of message.</p> <p> This is a phone message.</p> <p> This is a text message.</p>

	<p> This is a message read receipt.</p> <p> This is a forwarded phone message.</p> <p> This is a forwarded text message.</p> <p> This is a reply to a phone message.</p> <p> This is a reply to a text message.</p> <p> This is an Outgoing call.</p> <p> This is an email reply.</p> <p> This is an email read receipt.</p> <p> This is an email delivery failure.</p>
	<p>The third column indicates the Follow Up Status of the message.</p> <p>If there is no icon then the message is not marked for Follow Up.</p> <p> The message is marked for Follow Up.</p> <p> Follow Up has been completed on this message and no further action is required.</p>
ID	This column shows the Message ID.
Date	This column shows the date and time of the message.
Caller	This column shows the Caller if it is a phone message. It will be blank for text or system messages.
Company	This column shows the Company if it is a phone message. It will be blank for text or system messages.
Subject	This column shows the Subject of the message.
Phone	This column shows the phone number if it is a phone message. It will be blank for text or system messages.
Category	This column shows the Category selected for the message.

Reference	This column shows the Reference field from the selected message.
Identification	This column shows the Identification field from the Address Book entry for the caller.
Contact Type	This column show the Contact Type field from the Address Book entry for the caller.

Changing the Order of Columns

You can change the order of columns displayed in the message lists. This is done by clicking on a column and, while keeping the left mouse button pressed, dragging it to a new position. The insertion point will be highlighted with two red arrows.

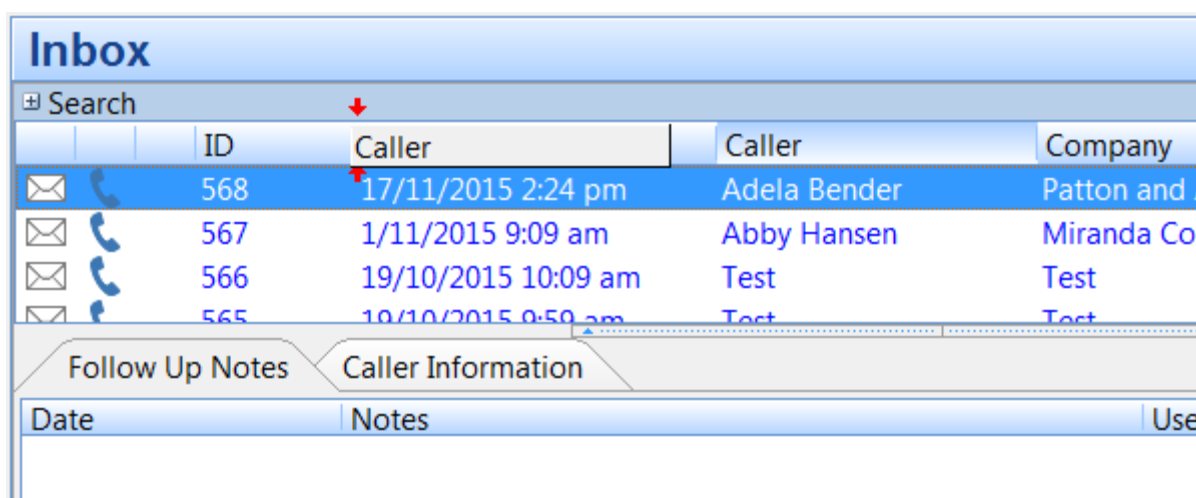

In the above example, the **Caller** column is being moved to a new position.

PhonePad will remember these positions so that they are persistent between PhonePad sessions.

Changing the Width of Columns

You can change the width of columns in the message lists. Just place your mouse cursor over the line between column headings and when it changes to a double-arrow cursor, click and hold the mouse button, and drag the column to a new size.

		ID	Date	Caller	Company
✉	☎	568	17/11/2015 2:24 pm	Adela Bender	Patton an
✉	☎	567	1/11/2015 9:09 am	Abby Hansen	Miranda C
✉	☎	566	19/10/2015 10:09 am	Test	Test
✉	☎	565	19/10/2015 9:59 am	Test	Test

PhonePad will remember the column widths between login sessions.

Selecting Which Columns to Display

If you don't want all columns displayed in the message lists, there is an option to change this.

Right-click on the Inbox message list and select **Message List Columns** from the popup menu.

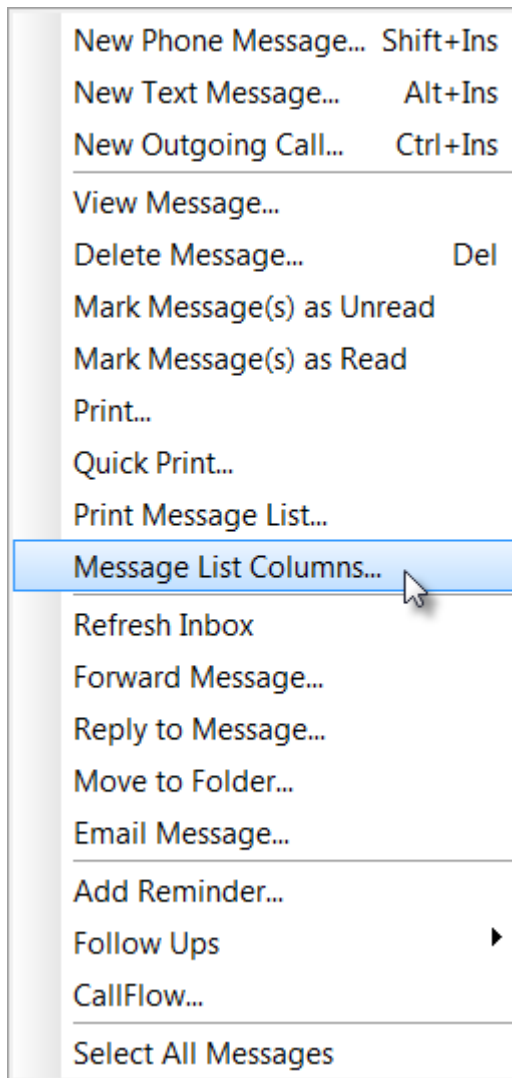

The following window will be displayed:

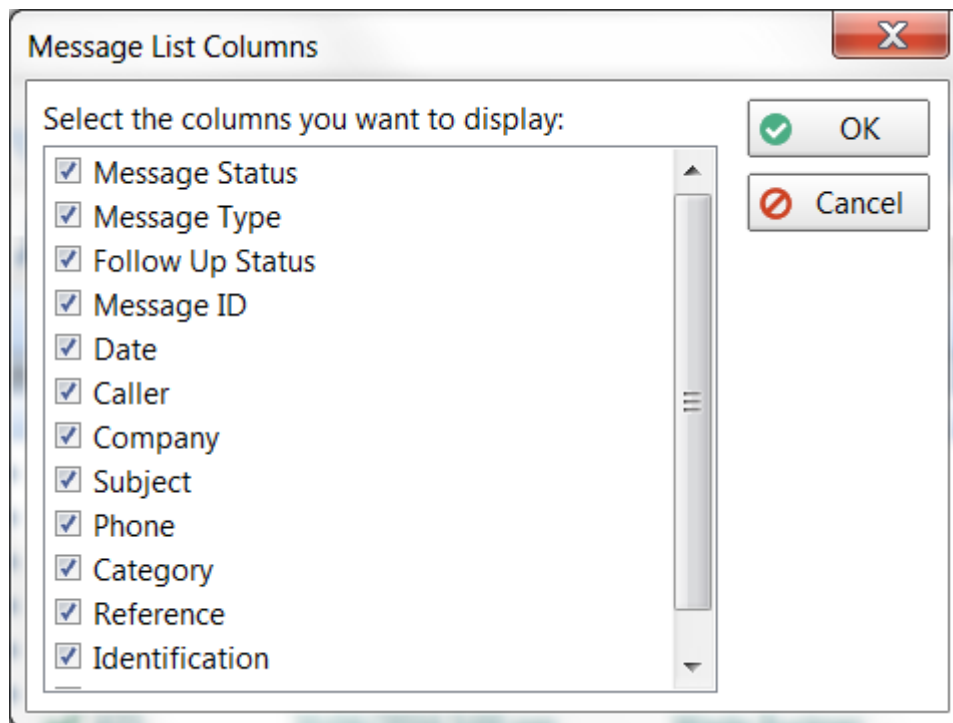

By checking or unchecking the various check boxes, you can select which columns you want displayed in the message lists. This affects all message lists.

Color Coding

Message lists also use color coding to identify the status of messages. These are the default colors:

BLUE	Unread message.
RED	Urgent message.
BLACK	Read message.
GREEN	Private message.
FUCHSI A	Message marked for Follow Up.
TEAL	Follow Up completed on the message.
PURPL E	Group message.

You can change the colors used by selecting **Preferences** from the **Tools** menu, then selecting **Messages-3**.

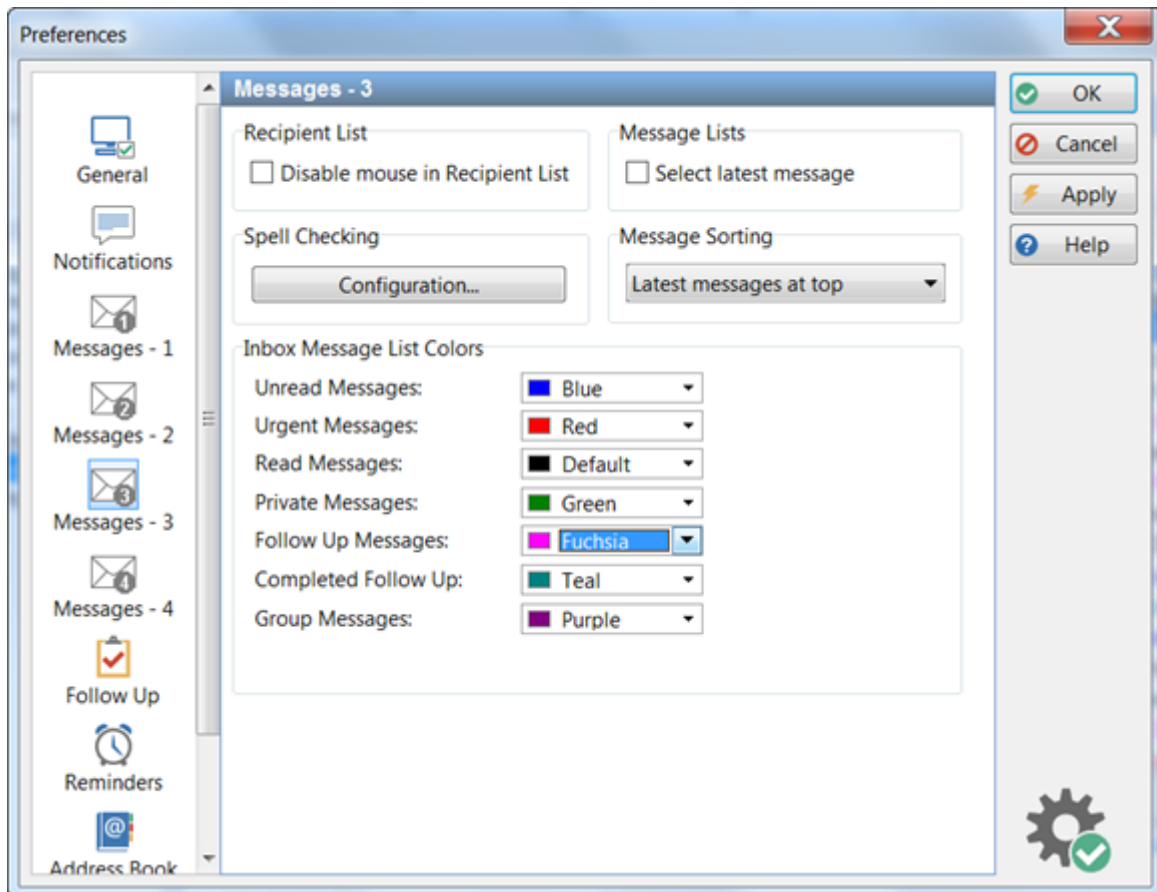

Search Bar

Each message list has a built-in search function, located at the top. Click the small + button to open the **Search Bar**.

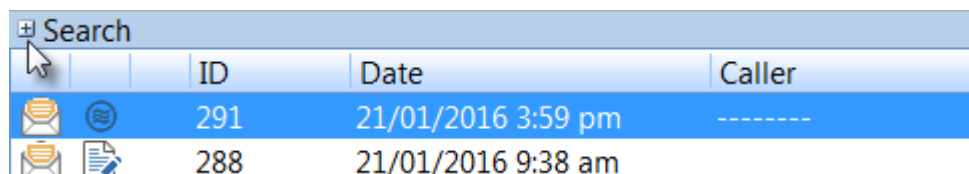

Once the Search Bar has been expanded you can enter the text you want to search for.

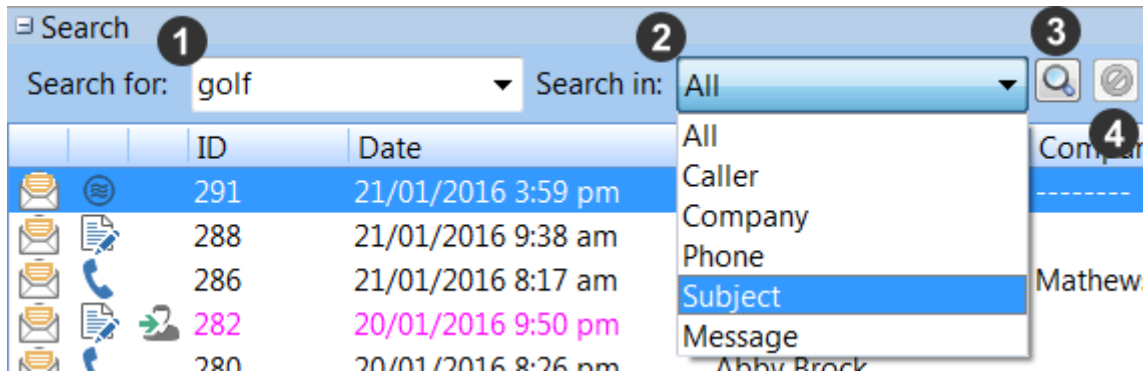

1. Enter your **Search Text**.
2. Select the field you want to search.
3. Click the **Search** button.
4. Click the **Cancel** button to cancel the search.

The message list will only display messages that match your search criteria.

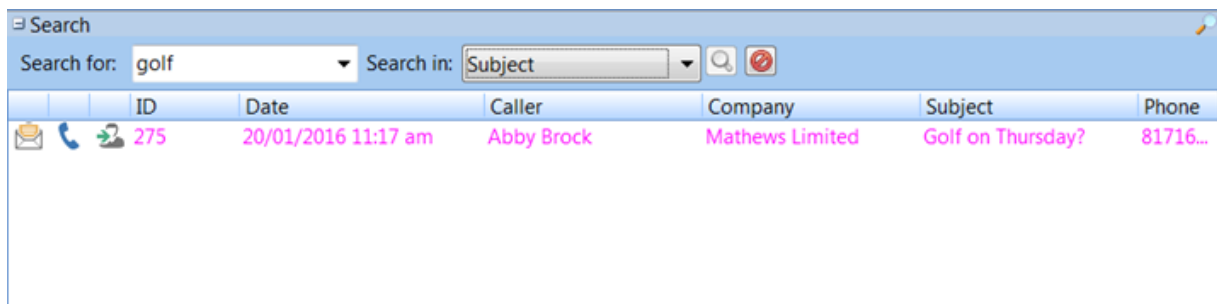

To cancel the search just click the **Cancel** button. The message list will then show all messages again.



The Search Bar only searches the messages in the current folder. If you want to search all messages then use the main Search option.

Information Panel

Below the Message List is an information panel, separated by a splitter. Every folder has a **Follow Up Notes** tab, except for the Inbox which has 3 tabs: Follow Up Notes, Caller Information and Preview.

Follow Up Notes

The **Follow Up Notes** tab shows all follow up notes for the selected message. This tab is always visible, unless you close the splitter.

Followup Notes		
Date	Notes	User
28/09/2015 1:02 pm	Left another message.	Stev
28/09/2015 9:37 am	Return Abby's call and left a voicemail message.	Stev

Caller Information

Caller Information displays details about contact information for the selected message. It allows you to view all phone numbers for the caller without having to open the message or look them up in the Address Book.

Caller Information			
Caller:	Abby Brock		
Company:	Mathews Limited		
Business Phone:	8171612	Home Phone:	8795641
Business Alt Phone:	8171614	Home Alt Phone:	
Business Cell/Mobile:	8894563	Home Cell/Mobile:	8997412
Business Fax:		Home Fax:	

This tab is shown/hidden by selecting **Caller Information** from the **View** menu.

Message Preview

Message View displays details about the selected message. It allows you to view most of the information without opening the message.

Followup Notes	Caller Information	Preview
To:	steve	Date: 20/01/2016
		Time: 11:17 am
Caller:	Abby Brock	Phone: 8171612
Company:	Mathews Limited	
Subject:	Golf on Thursday?	
Message:	Abby rang to see if you are still up for a game of golf on Thurssday.	

This tab is shown/hidden by selecting **Message View** from the **View** menu.

Splitters

You may have noticed these little dividers between panes on the main window.

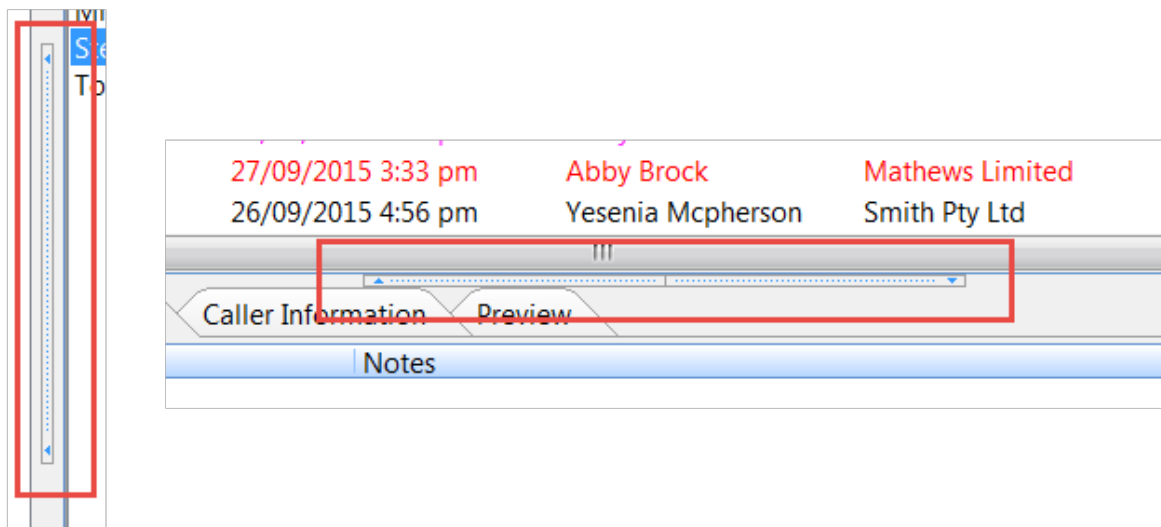

Image: Horizontal and Vertical splitters.

These are called "splitters" as they split the panes they are connected to. These splitters allow you to resize the pane you are viewing so that you can see them better. If you click on the bar with the arrows, it will open or close one of the panes.

If you position the mouse cursor outside of the bars you will see a double-arrowed cursor. By then clicking on the splitter you can resize either pane to your liking.

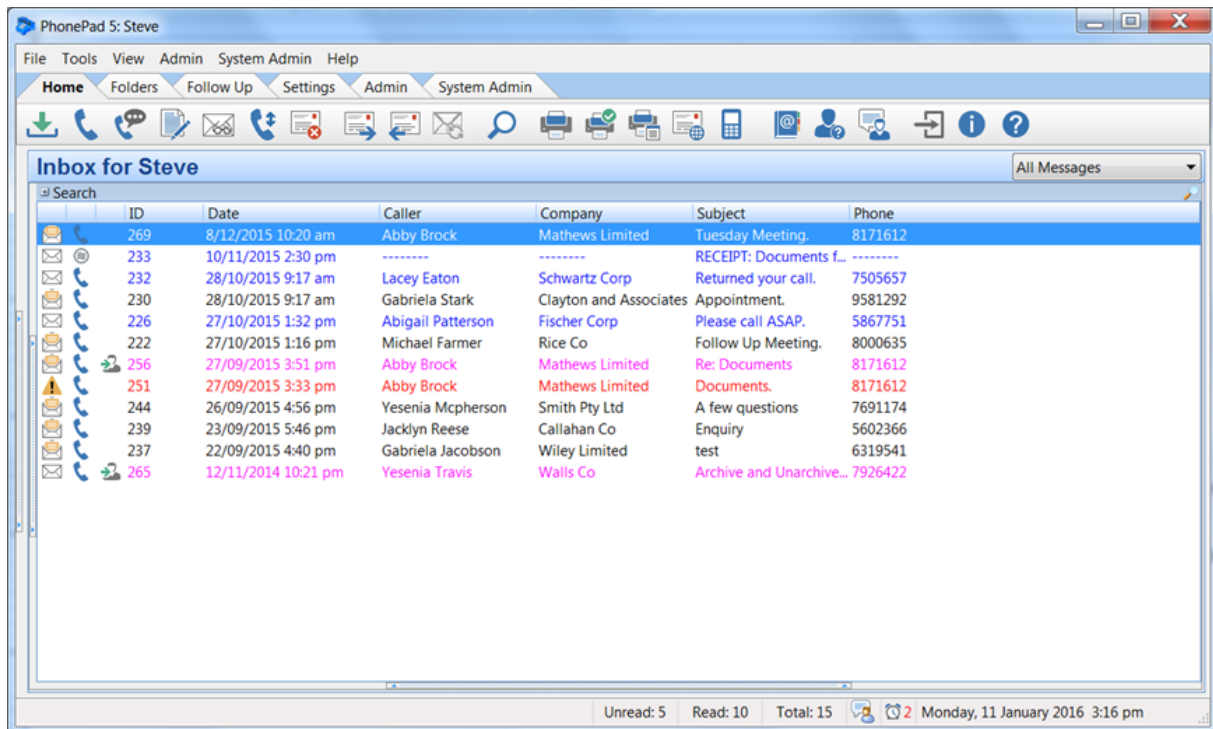
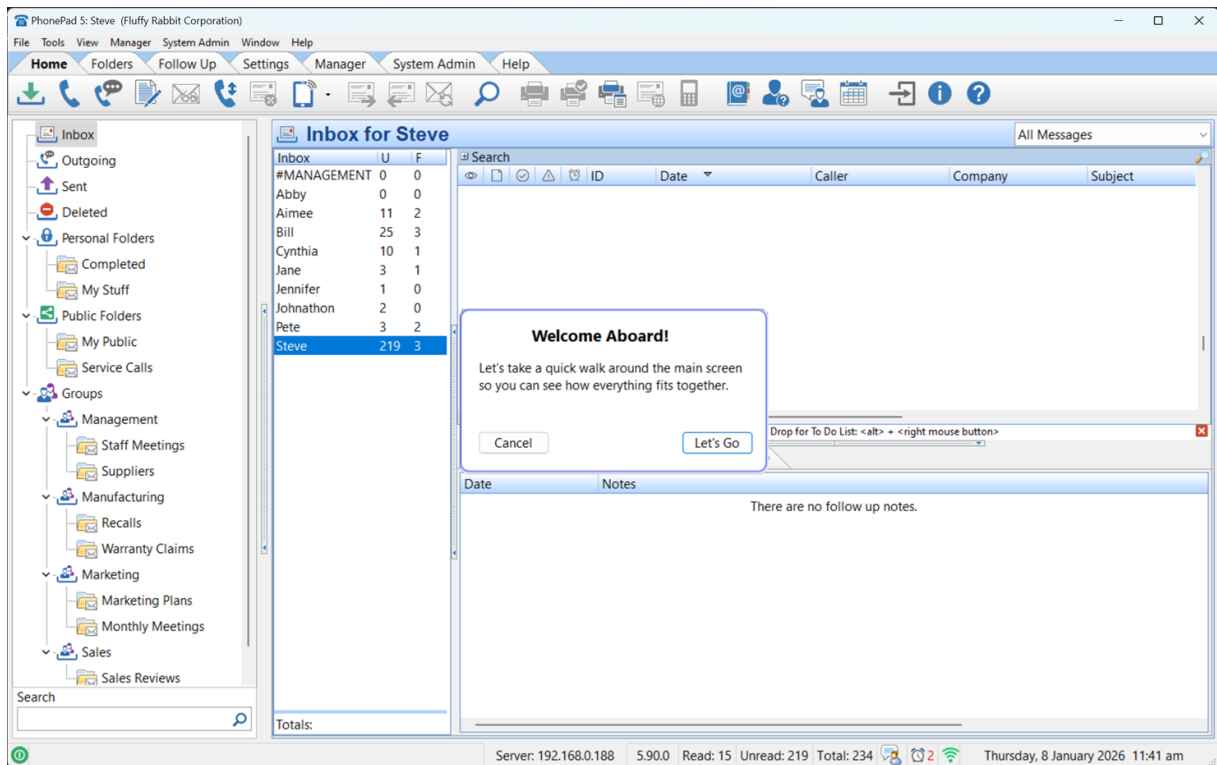

Image: All splitters closed.

In this example you can see that all of the splitters have been closed, allowing the Inbox to fill up all of the available space.

Guided User Interface Help

When you login to PhonePad for the *first time*, the **Guided User Interface Help** will be displayed.



You can display this help at any time by selecting **Guided Help** from the **Help** menu, or by clicking on the **Guided Help** button on the **Help** toolbar.

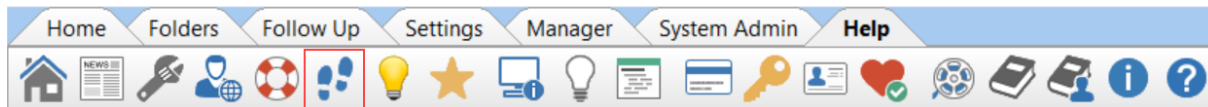
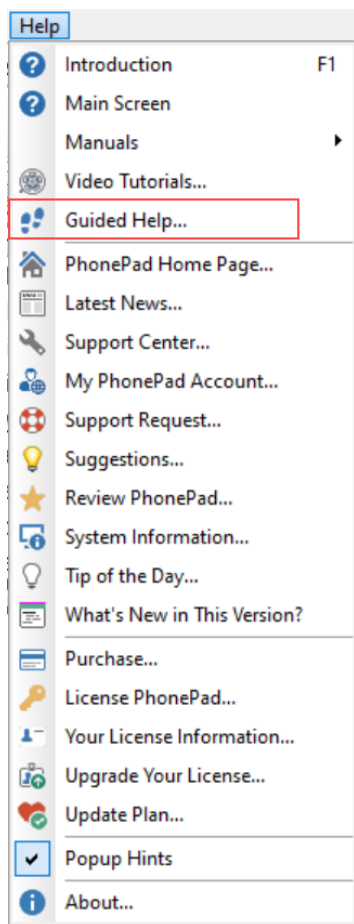

User Interface Modes

PhonePad 5 can seem a little overwhelming with the many features and options available. To help ease into using PhonePad you can minimize the number of features available using *User Interface Modes*.

There are 3 modes available: *Basic*, *Standard* and *Advanced*. *Basic* and *Standard* show a subset of features, while *Advanced* (the default) shows all features.

You can set the mode by selecting **User Interface Modes** from the **View** menu, and then selecting the appropriate mode.

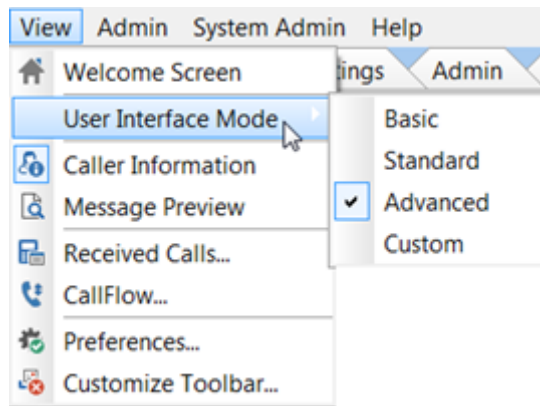

If you want more precise control over which buttons are shown on the toolbars, use the Toolbar Configuration feature. The *Custom* mode is used when you modify the toolbar configuration.

Configuring the Toolbars

If you don't use all of the features in PhonePad you can modify the toolbars so that only the buttons for the features you use are shown.

To do this, select **Customize Toolbar** from the **View** menu.

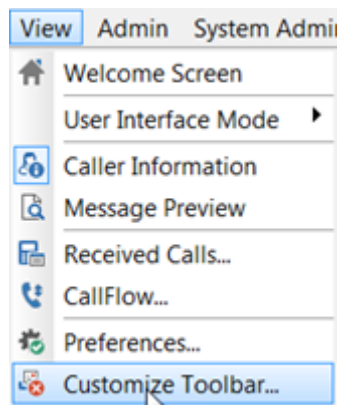

The **Customize Toolbar** window will appear.

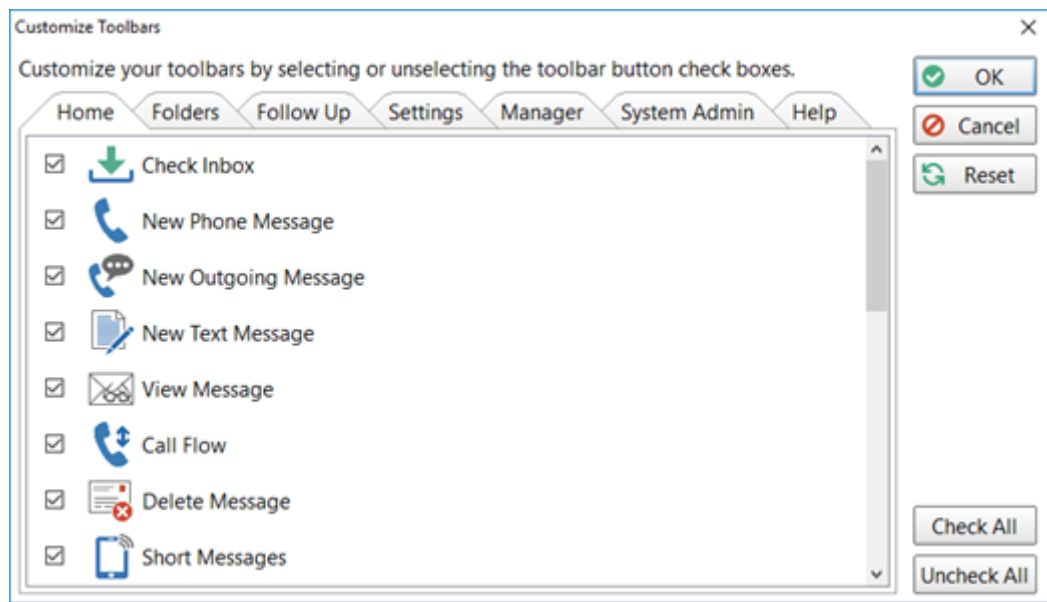

Each of the toolbar tabs are shown (only administrators will see the admin tabs).

To hide a button from the toolbar just uncheck the check box next to it.

When you have made all the changes you want, click the **OK** button to save them.

The **User Interface Mode** option on the **View** menu will be set to *Custom*. You can easily switch between showing all toolbar buttons or just the buttons you have set by selecting either *Advanced* or *Custom*.

System Administrators can also configure the toolbars for all users in System Rules.

Message Notification Service Error

During the installation process on a workstation, the **Message Notification Service** is also installed. This service is responsible for updating the Inbox and other folders, as well as lookup lists and other features.

If the service doesn't start automatically when installed, you will get this message when logging in to PhonePad.

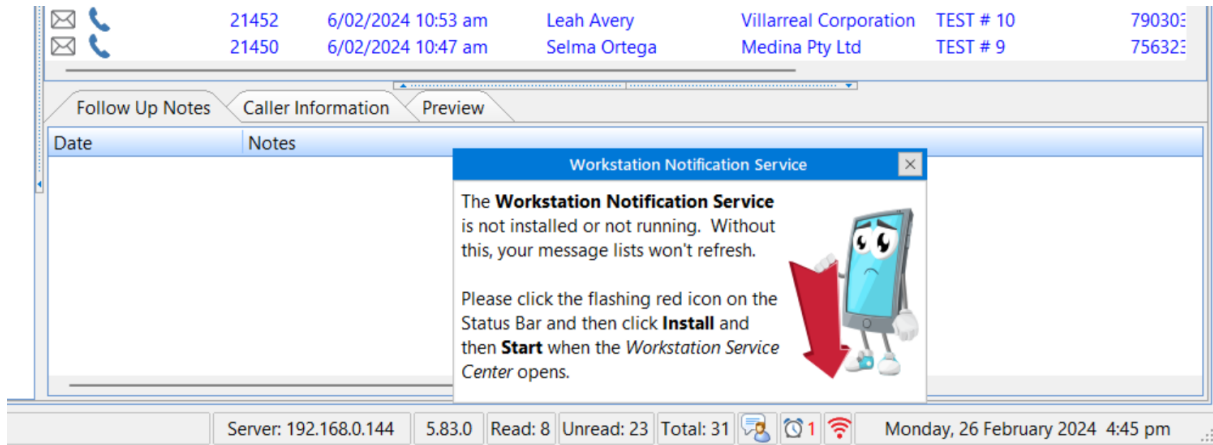

The **red** icon on the status bar the message is pointing to will be flashing, just in case the message didn't get your attention.

To fix this all you need to do is click on the flashing icon.

The **PhonePad Workstation Service Center** will then be displayed. If the Install button is enabled and the other buttons are disabled, it means that the installation process was unable to install the service for you.

Just click the **Install** button to install the service.

When the **Start** button is enabled, click on it and then click the **Exit** button

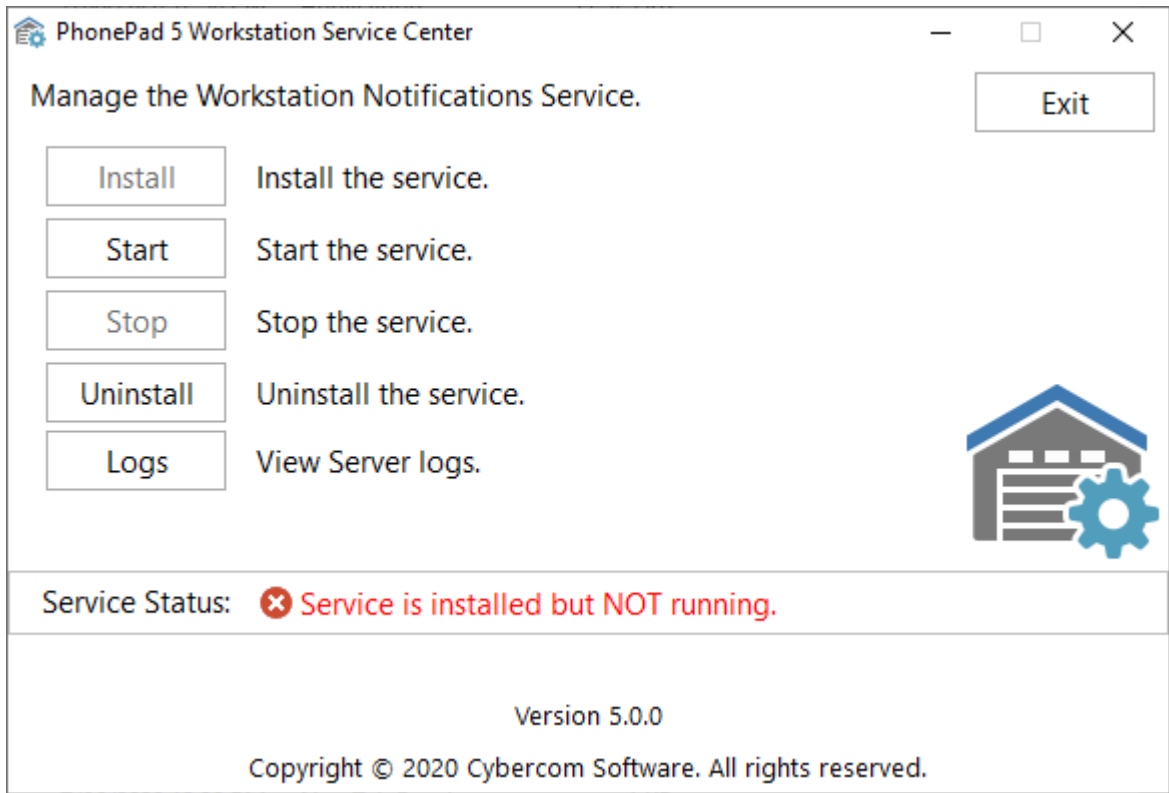

You should see the Notification Service icon in PhonePad's status bar is now **green**.

This page intentionally left blank.

Chapter

3

Messages

Messages

Phone messages is what PhonePad is all about. You can keep a record of all incoming and outgoing calls, as well as any follow up action performed. There are also text messages for intra-office communication.

Phone Messages (Incoming)

This message form is used to log details of incoming calls. Don't be intimidated by the number of fields. Although it may look a little complicated from this screenshot, it is actually quick and easy to use. And you don't need to complete all of the fields. Many labels and fields can be customized to suit your business and workflow.



1	Click the TO button to display a list of all PhonePad users. Select the users you want the message sent to.
2	As an alternative to clicking the TO button, you can just type the user names in this field. It will automatically do an incremental search and find the user's name for you. Press <ENTER> to select a name.
3	The date field is automatically filled in for you but you can change it if needed.

4	The time field is automatically filled in for you but you can change it if needed.
5	Click the Caller button to look up the caller's details (if they are in the Address Book).
6	Type in the Caller's name. If they exist in the Address Book PhonePad will fill in the details for you.
7	Click the Add Caller button to enter additional details about a <i>new</i> caller.
8	Click the Address Book button to open the Address Book entry for an <i>existing</i> caller. This allows you to update any additional details.
9	<p>Enter the caller's phone number. If the caller already exists in the system then this will be pre-filled for you, but you can change it if the number is different.</p> <p>The small phone icon next to the phone number field lets you select from a number of phone numbers for the user.</p>
10	This is the company the caller is from. If the caller isn't from a company you can leave this blank.
11	You can assign this call to a Category (if your administrator has set them up).
12	Select an item from the drop-down list, eg. Phoned, Returned Your Call, and Came to See You. This list can be changed by Managers and Administrators.
13	If checked, any user who has access to your folders will not be able to read the content of the message unless they are one of the recipients.
14	<p>Click the Notes button to add notes about the caller.</p> <p>The Caller Notes window will be displayed. There are 10 tabs of notes that you can add. These will be stored in the Address Book entry for the Caller.</p>

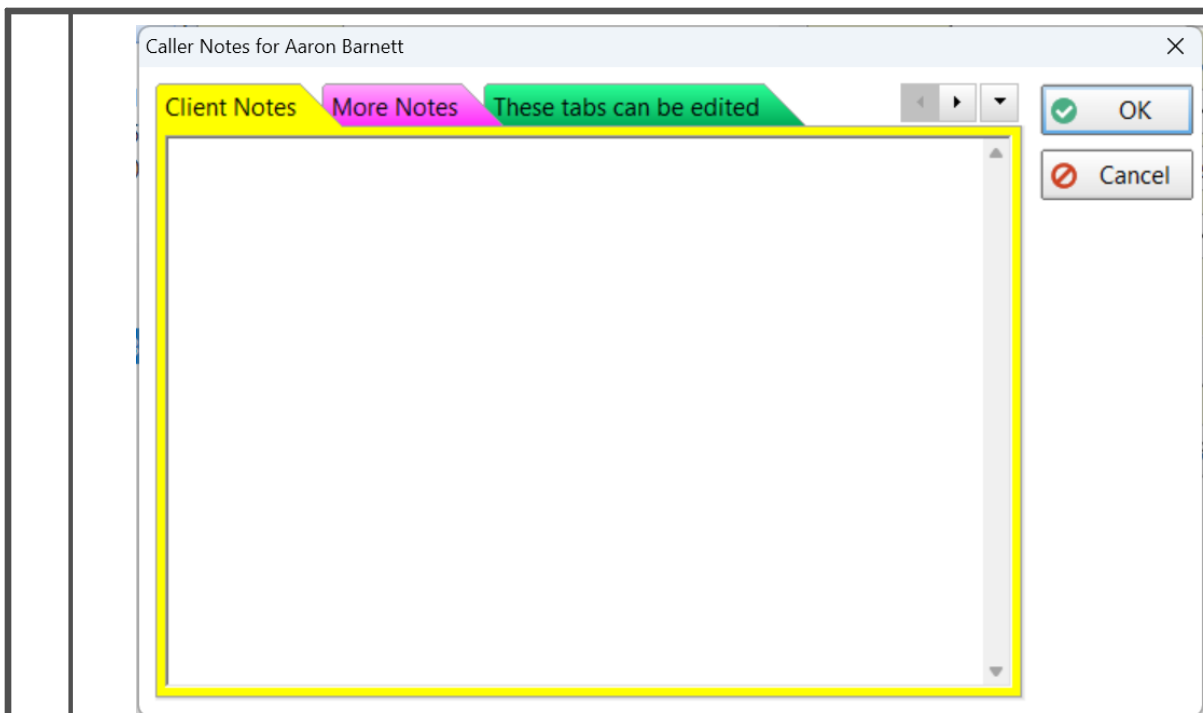

As you can see, the names of the Notes tabs, and the colors of the tabs, can be changed to suit your needs (this is done by a System Administrator under **System Rules**).

<p>15</p>	<p>Select an item from the drop-down list, eg. No Action Required, Please Phone, Will Phone Again, Will Drop By Again, Wants to See You. This list can be changed by Managers and Administrators.</p>
<p>16</p>	<p>If checked, you will receive a message when the recipient/s read the message.</p>
<p>17</p>	<p>If checked, a follow up deadline will be placed on the message - you can specify the follow up date.</p>
<p>18</p>	<p>Enter information on when the caller will be available.</p>
<p>19</p>	<p>If checked, the message will be marked as Urgent.</p>
<p>20</p>	<p>This field can either be an edit fields or a drop-down list. The name and the drop-down list contents can be changed by a Manager or Administrator. This field can be configured not to appear.</p>
<p>21</p>	<p>This field can either be an edit fields or a drop-down list. The name and the drop-down list contents can be changed by a Manager or Administrator. This field can be configured not to appear.</p>

22	You can enter the caller's email address in this field. The email address will be added or updated for this caller in the Address Book. This field will not be visible if the Show Email Address check box is unchecked in the Label Editor.
23	You can enter the caller's Date of Birth in this field. The Date of Birth will be added or updated for this caller in the Address Book. This field will not be visible if the Show Date of Birth check box is unchecked in the Label Editor.
24	Subject of the message.
25	A free form text field that can also be used for other messages. When you enter text in this field, it can be accessed for other messages (by any user).
26	You can add attachments to messages. If there is an attachment, the number of attachments will be shown in a red circle (which is known as a "Badge").
27	Toolbar for the message text.
28	The message text is where you enter additional details of the call.
29	Your name will be entered here by PhonePad when you create a new message. This cannot be changed.
30	Click the Options button to add the following to message text: Date/Time Stamp, Insert Separator at Top, Insert Separator at Bottom.
31	When checked, some fields will display their keyboard shortcuts when the mouse hovers over them.
32	Click the Send button to send the message.
33	Click the Cancel button to cancel the message.
34	Click the Help button to display online help.
35	Click the Suggest button to invoke Smart Assistance.

Logging an Incoming Call

To log an incoming phone call, click the **New Phone Message** button on the toolbar, or select **New Phone Message** from the **File** menu, or press the **<shift>** **<insert>** keys on your keyboard.

Message Date and Time

PhonePad will automatically fill in the current date and time for you. You can change these if needed.

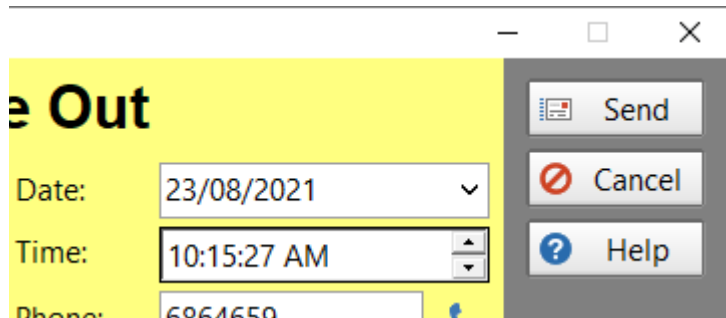

To change the date, you can either type it in or select it from the drop-down calendar.

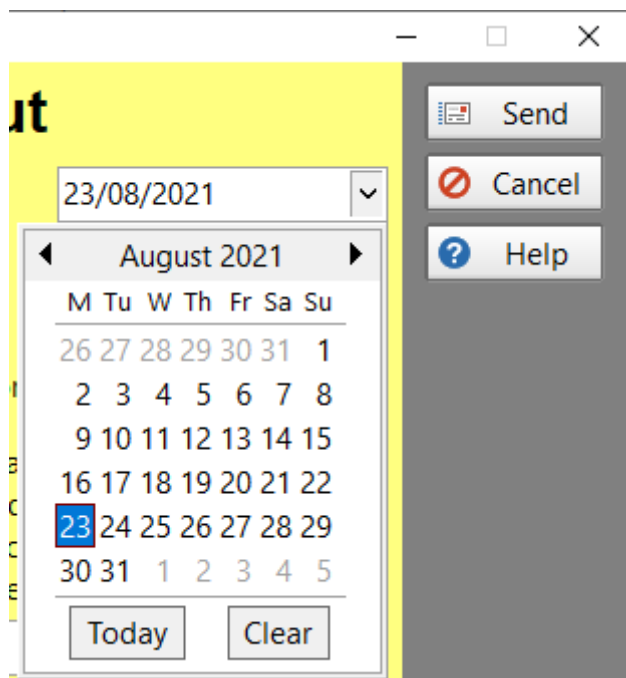

You can edit the time directly, or you can use the up and down arrows keys on your keyboard to change the hour, minutes and am/pm. You can also use the up and down arrow buttons of the **Time** field.

Use the left and right arrow keys to move between hours, minutes and am/pm.

Recipients

The first step is to address the message to at least one person.

The fastest way to do this is to type in the **To** field.

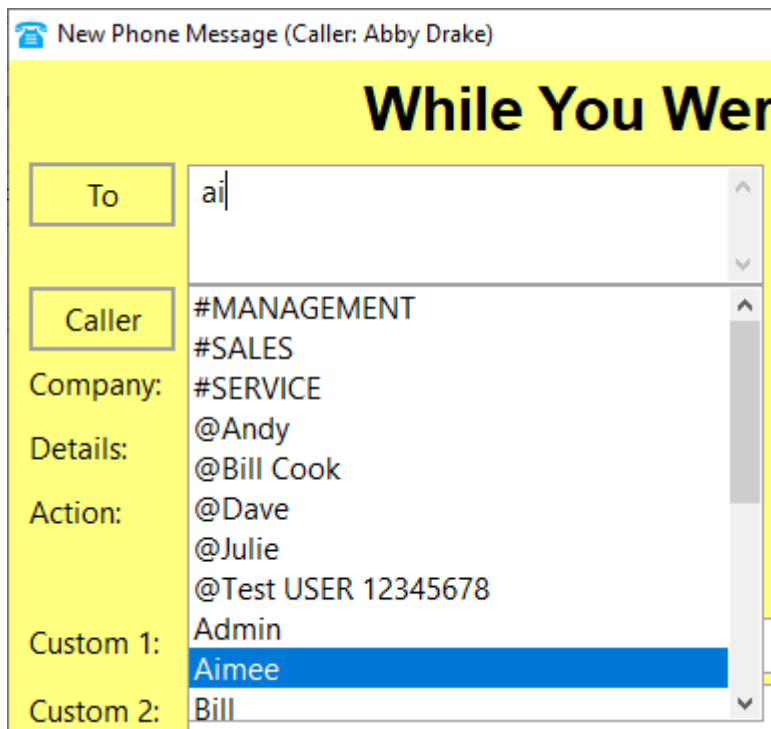

As you type in a name, PhonePad will drop down a list of users and perform an incremental search. Press **<enter>** to select a user. You can add additional users if you want.

Names beginning with a # are groups, eg. #Service. When you send a message to a group it will be sent to everyone in the group.

Names beginning with an @ are External Users, eg. @Aimee. When you send a message to an external user the message doesn't go into an Inbox but instead is placed on the message queue and is sent by email, SMS and/or Pushover.

You can also select names by clicking the **To** button. The **Users** tab allows you to select users while the **Groups** tab allows you to select groups. You can expand a group to see who the members are.

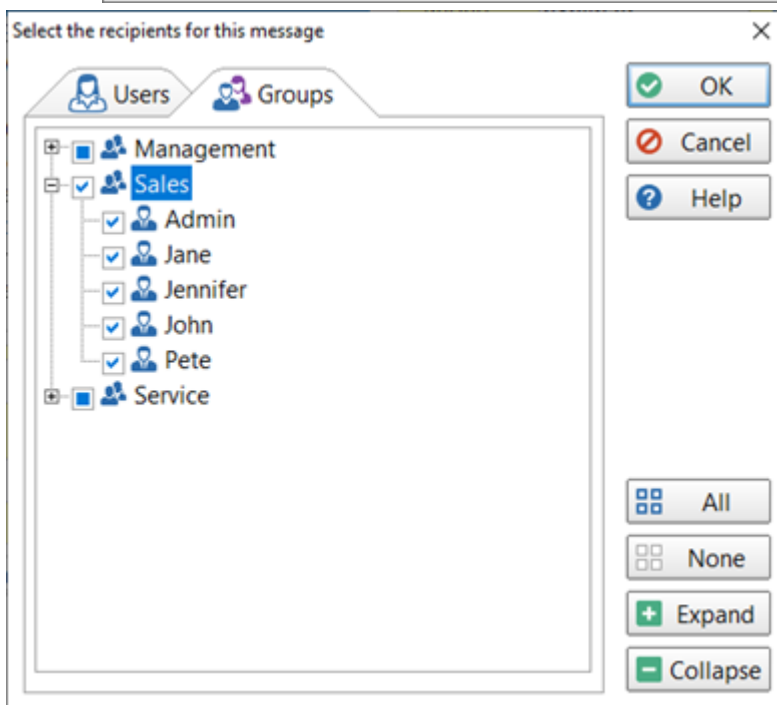
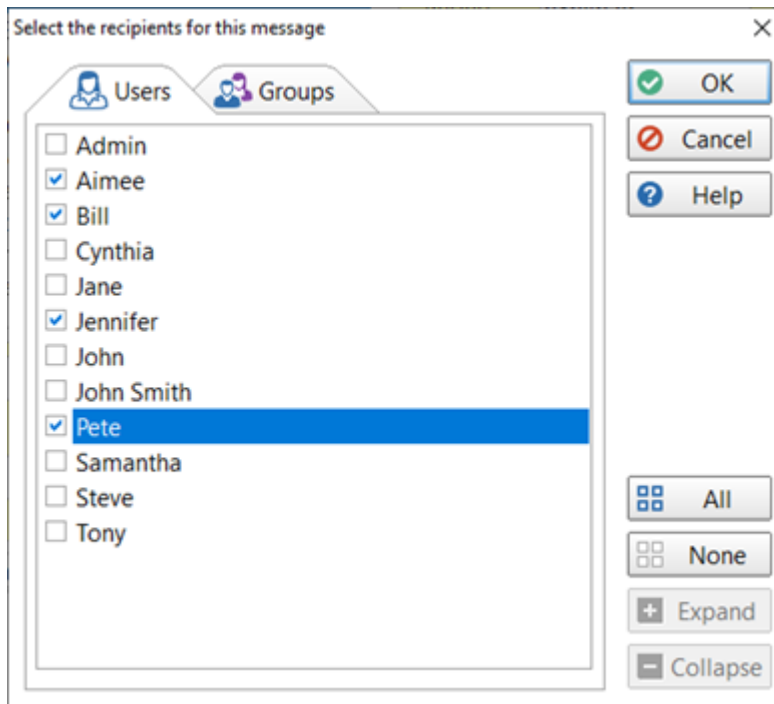

Caller's Name

Type the name of the caller in the **Caller** field. PhonePad will perform an incremental search to try to locate the caller's name.

New Phone Message (Caller: Abby Drake)

While You

To: Aimee,

Caller: Abby Drake

Company: Abby Drake

Details: Abby Farmer

Action: Abby Hansen

Abby Mcdowell

Abby Mckinney

Abby Mclaughlin

Abby Padilla

Custom 1: Abby Robbins

If the caller appears in the list, select their name and press the **<enter>** key. If the caller isn't in the list just type in their name and press the **<enter>** key.

You can also select a Caller by clicking on the **Caller** button. The **Caller Lookup** window will appear.

Caller Lookup

Search text: Fullname

Caller	Company	City	State	Phone
Abby Delaney	Mcdonald Pty Ltd			9884925
Abby Drake	Fischer and Sons			6864659
Abby Farmer	Walters Co			9312409
Abby Hansen	Miranda Company			5573188
Abby Mcdowell	Rich Corporation			9285957
Abby Mckinney	Stafford Corp			6614732
Abby Mclaughlin	McMahon and Associates			8153766
Abby Padilla	Crane LLC			8937445
Abby Robbins	Hull Corp			7128938

Caller: Abby Drake Company: Fischer and Sons

Address 1: Address 2:

City: State: Postal Code:

Country: Phone: 6864659

Alt. Phone: 6869606 Fax:

Cell/Mobile: 5556789 Email:

OK Cancel Help

Enter your **Search Text** and select the fields you want to search, then click the **Search** button.

When you select a name from the list their details will appear below so you can verify it's the right person. Click **OK** to select the caller.

If you want to add a new caller, you can do this by either entering their name, company (if applicable) and phone number, or by clicking the **Add** button next to the **Caller** field.

Adding a New Caller with Additional Details

When you enter a new caller in a phone message a new entry will be added to the Address Book (providing you have this option set) with the caller's name, company and phone number(s).

There is another way to add a new caller but with extra information. Click the **Add** button next to the **Caller** field.

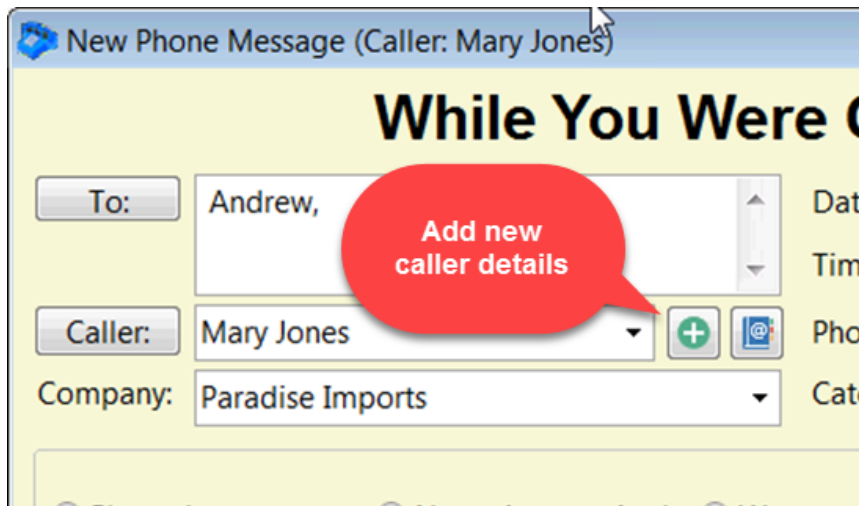

The **Add New Caller** window will be displayed.

A screenshot of a dialog box titled "Add Caller: Mary Jones" with a close button (X) in the top right corner. The dialog has two tabs: "Caller Details" (selected) and "Map". On the right side, there are three buttons: "OK" (with a green checkmark), "Cancel" (with a red X), and "Help" (with a question mark). The main area contains several input fields and radio buttons. On the left, there are fields for "Firstname:" (Mary), "Lastname:" (Jones), "Company:" (Paradise Imports), "Address 1:" (Carmichael Road), "Address 2:" (empty), "City:" (Nassau), "State:" (empty), "Postal Code:" (empty), "Country:" (The Bahamas), and "Address Type:" (Business Address). On the right, there are radio buttons for "Business Phone:" (selected, with value 123456), "Business Cell/Mobile:" (empty), "Home Phone:" (empty), and "Home Cell/Mobile:" (empty).

On this screen you can not only enter the name, company (if applicable) and phone number for the caller, you can also enter their address and other phone numbers.

When you have entered the address, select the **Address Type** so PhonePad knows which fields to populate in the Address Book.

If you like, you can enter multiple phone numbers and then select the phone number type for the call.

If you click on the **Map** tab you can look up their address on Google Maps and then save it into the system.

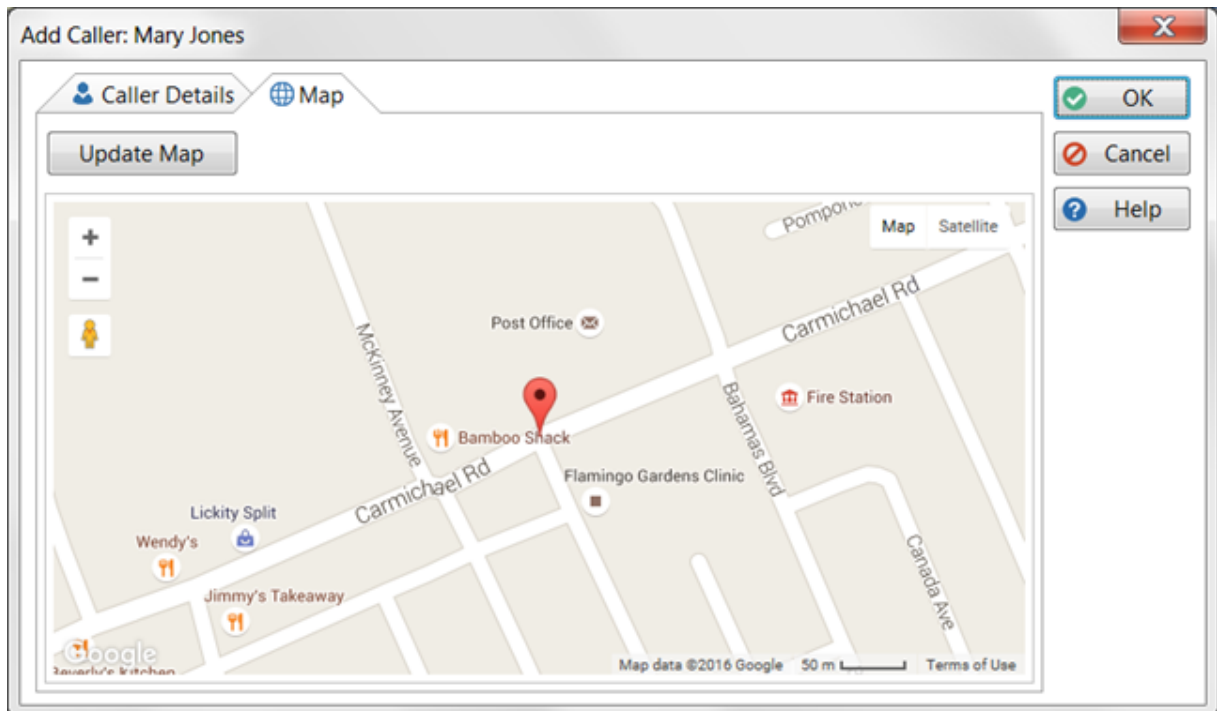

When you click the **OK** button, the details you entered will be added to the Address Book and the **Firstname, Lastname, Company** and selected phone number will be added to the message form.

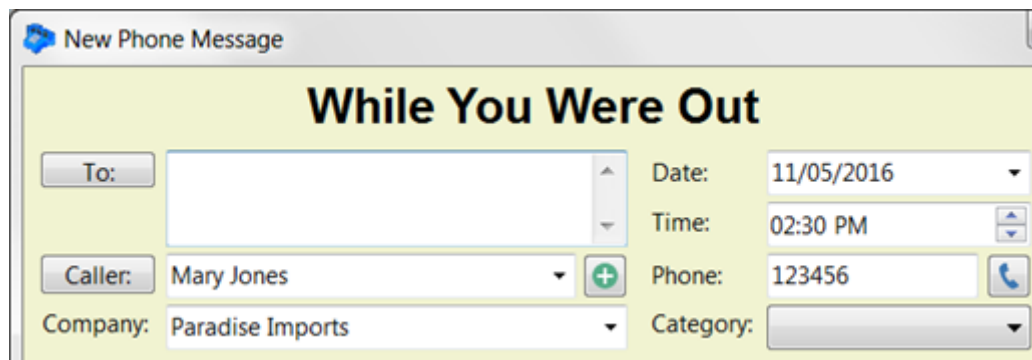
The image shows a "New Phone Message" form. The title "While You Were Out" is prominently displayed at the top. The form contains several input fields: "To:" (empty), "Date:" (11/05/2016), "Time:" (02:30 PM), "Caller:" (Mary Jones), "Phone:" (123456), "Company:" (Paradise Imports), and "Category:" (empty). There are also small icons for adding a new caller and a phone icon next to the phone number field.

Editing an Existing Caller

If the caller you are entering for the call already exists in your Address Book, you can click the **Address Book** button to open their details.

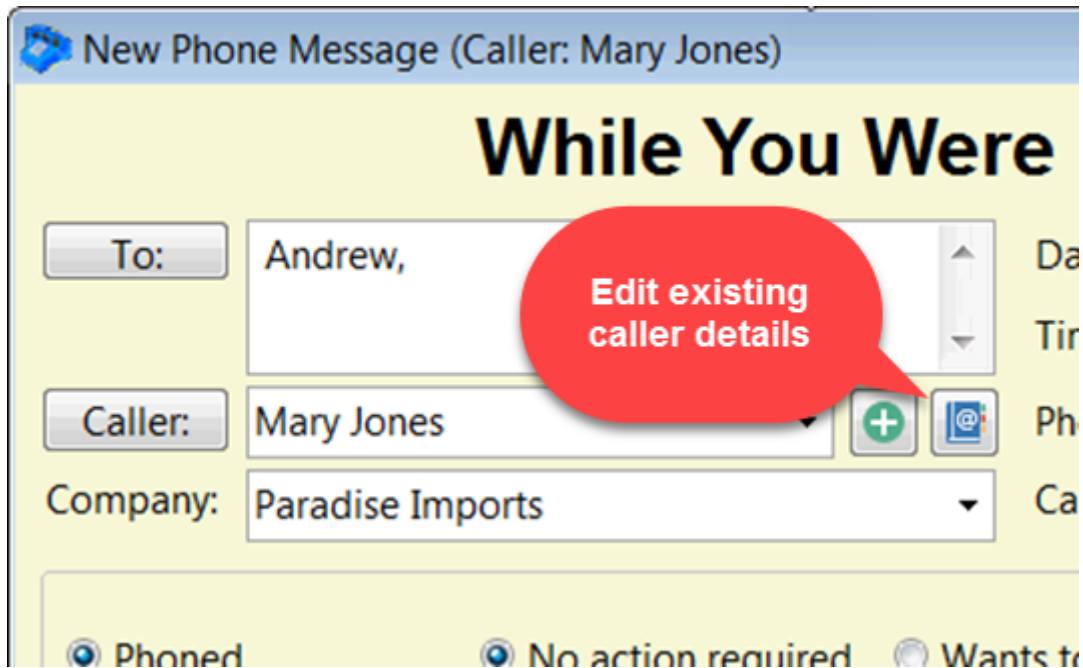

The **Update Entry** screen will be displayed.

Update Entry

Caller Information

Fullname: Mary Jones

Job Title:

Company: Paradise Imports

OK

Cancel

Print

Help

General Business Postal Home Map Family Notes

Title:

Firstname: Mary

Middlename:

Lastname: Jones

Date of Birth:

Age Now:

Identification: Client No, Patient No, etc.

Contact Type:

Load... Save... Clear...

Private Address Book Entry

Added by: Steve Updated by: Steve

Date: 11/05/2016 2:42:18 PM Date: 11/05/2016 2:42:18 PM

This allows you to update any information for the caller.

Phone Number

Enter the phone number in the Phone field. If the caller you selected is already in the system this field will be prefilled for you.

You Were Out

Date: 20/01/2016

Time: 08:57 AM

Phone: 8171612

Category:

If you click the button with the telephone icon, you can select additional phone numbers if there are any.

You Were Out

Date: 23/08/2021

Time: 10:15:27 AM

Phone: 6864659

Category:

- Private
- Read Re
- Follow
- Urgent

Bus Phone	6864659
Bus Alt Phone	6869606
Bus Fax	
Bus Cell/Mobile	5556789
Home Phone	5559202
Home Alt Phone	5557932
Home Fax	
Home Cell/Mobile	5559034

Buttons: Send, Cancel, Help

Normally the Phone field is a free-form text field, which means you can enter phone numbers in any format you like. However, if your PhonePad administrator has specified a phone number format for the Phone field then you will be restricted to that format.

Were Out

Company

If the caller is from an organization you can select a **Company** from a list of companies known to PhonePad (via the Address Book). As you type in a name PhonePad will perform an incremental search, narrowing down the company names to match what you type in. Press the <enter> key to select a company.

If the name doesn't exist you can just type it in.

New Phone Message (Caller: Abby Drake)

While You Wer

To: Aimee,

Caller: Abby Drake

Company: Fields and Sons

Details: Fields and Sons

Action: Fields Co
 Fields Corporation
 Fields Limited
 Figueroa and Associates

Custom 1: Figueroa and Sons
 Figueroa Corp

Custom 2: Figueroa Corporation

If the caller has called before then the Company name will be automatically filled in for you, however, you can change it if required.

Category

If your PhonePad administrator has created some categories, you can select a Category from the drop-down list.

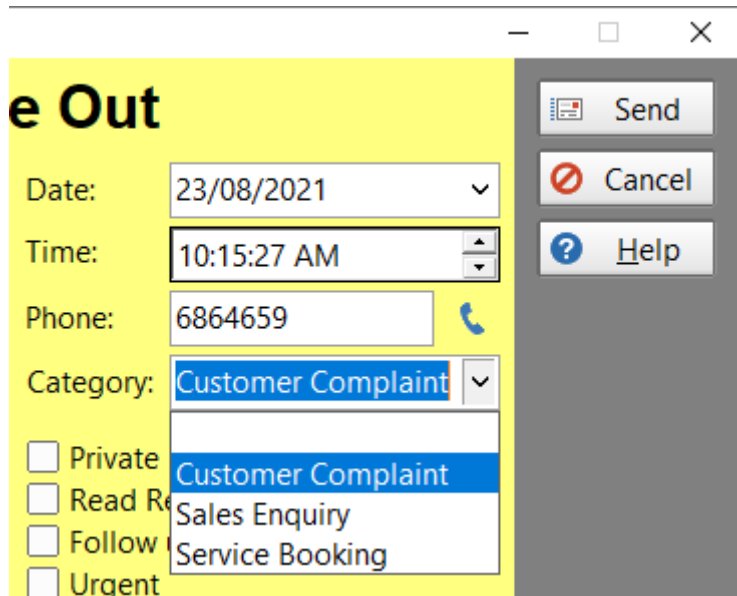

The screenshot shows a window titled "e Out" with a yellow background. On the left, there are several input fields: "Date:" with a dropdown menu showing "23/08/2021", "Time:" with a time picker showing "10:15:27 AM", "Phone:" with a text box containing "6864659" and a phone icon, and "Category:" with a dropdown menu showing "Customer Complaint". Below these are four checkboxes: "Private", "Read R", "Follow", and "Urgent". On the right side of the window, there are three buttons: "Send", "Cancel", and "Help". The "Category:" dropdown menu is open, showing a list of options: "Customer Complaint", "Sales Enquiry", and "Service Booking".

Message Details

Here is where you add some details about the call.

The first thing to select is information about the call. This is called **Details**. The default details are shown in the example below. Your list may look different if a Manager or Administrator has changed the list.

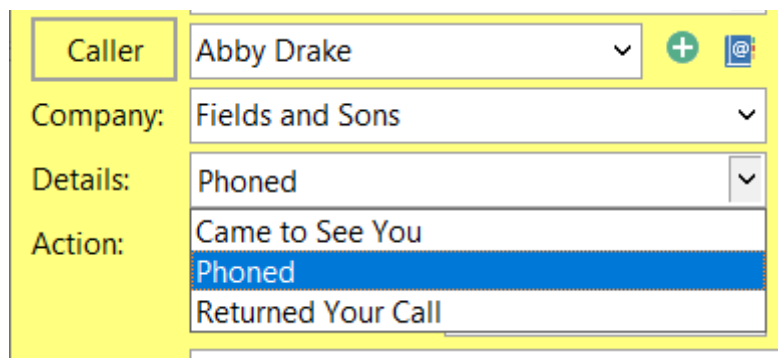

The screenshot shows a form with a yellow background. On the left, there are four input fields: "Caller" with a dropdown menu showing "Abby Drake", "Company:" with a dropdown menu showing "Fields and Sons", "Details:" with a dropdown menu showing "Phoned", and "Action:" with a dropdown menu showing "Came to See You". On the right side of the "Caller" field, there are two icons: a plus sign and a person icon. The "Action:" dropdown menu is open, showing a list of options: "Came to See You", "Phoned", and "Returned Your Call".

Next, select the required action. This is called **Action**. The default actions are shown in the example below. Your list may look different if a Manager or Administrator has changed the list.

The screenshot shows a form with the following fields:

- Caller:** Abby Drake
- Company:** Fields and Sons
- Details:** Phoned
- Action:** Please phone (dropdown menu is open, showing options: No Action Required, Please phone, Please phone)
- Custom 1:** Wants to see you
- Custom 2:** Will drop by again, Will phone again

The Will be in at option allows you to add some free-form text below it, eg. what time the Caller will be available.

And finally, there are some options you can select.

The screenshot shows a form with the following fields:

- Details:** Phoned
- Action:** Please phone
- Will be in at: After 2:00pm
- Private Message
- Read Receipt
- Follow up by: 29/08/2021
- Urgent

Private	When checked, only the recipients and sender of the message can view it. Anyone else who has access to your Inbox and folders will not be able to read the message unless they are also a recipient.
Read Receipt	When checked, you will receive a receipt message when a recipient has read the message.
Follow Up By	Check this check box if you want the message followed up by a specific date. You also need to select the follow up date. A reminder will be created for this message.
Urgent	When checked the message will be marked as Urgent.

Subject

The **Subject** is the subject of the phone call, although you can enter whatever you like in this field. .



A screenshot of the PhonePad interface showing the 'Subject' field. The field is highlighted with a red border and contains the text 'Golf on Thursday?'. To the right of the 'Subject' field is a 'Reference:' dropdown menu and an 'Attachments' button. Below the 'Subject' field is a 'Message:' label.

This field may be prefixed with some text that has been set up by your PhonePad administrator.

Reference

The Reference field is a free-form text field that can contain whatever text you want. Its purpose is to make the text available for future messages. When you enter text in this field, PhonePad will remember it so that the next time you create an incoming or outgoing phone message you can select the text from the drop-down list.

The text in the drop-down list is available for *all* users to access.

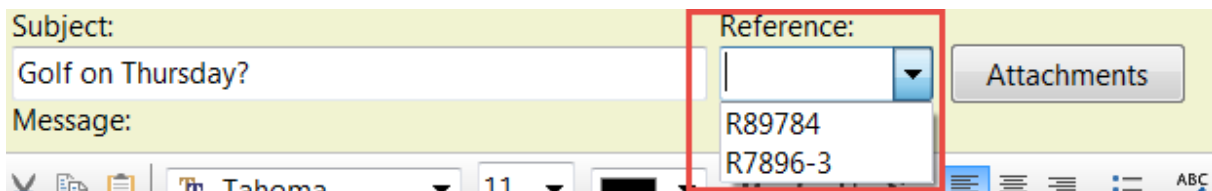

A screenshot of the PhonePad interface showing the 'Reference' field. The field is highlighted with a red border and contains a dropdown menu with two options: 'R89784' and 'R7896-3'. To the left of the 'Reference' field is the 'Subject' field containing 'Golf on Thursday?'. To the right of the 'Reference' field is an 'Attachments' button. Below the 'Reference' field is a 'Message:' label.

Possible uses for this field are: patient numbers, client numbers, file numbers and so on.

Attachments

You can attach up to 5 attachments to each message.

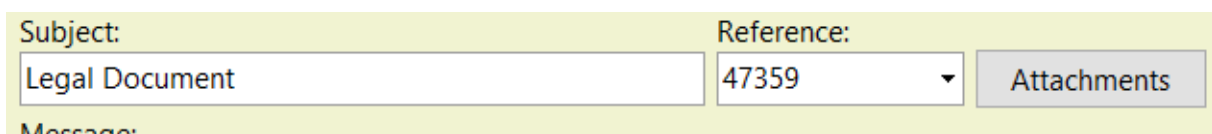

A screenshot of the PhonePad interface showing the 'Attachments' field. The field is highlighted with a red border and contains the text 'Legal Document'. To the right of the 'Attachments' field is a 'Reference:' dropdown menu containing '47359' and an 'Attachments' button. Below the 'Attachments' field is a 'Message:' label.

Click the **Attachments** button.

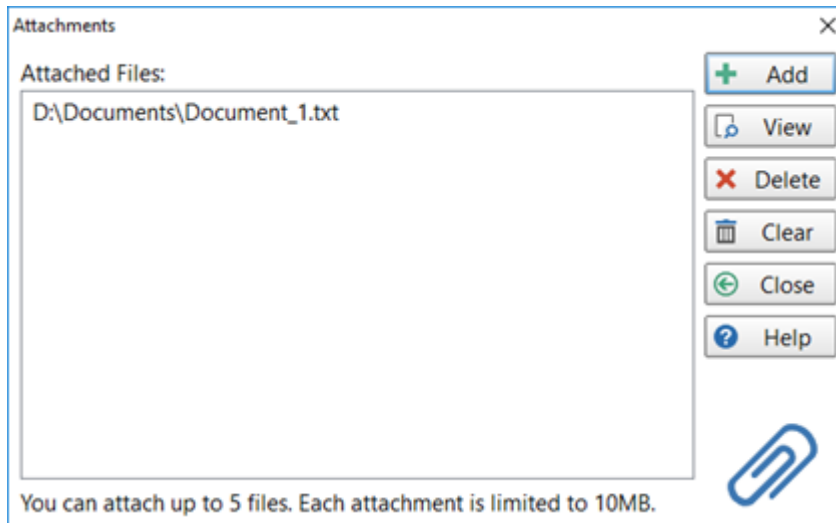

Add	Add an attachment. You can add up to 5.
View	View the selected attachment.
Delete	Delete the selected attachment.
Clear	Delete all attachments.
Close	Close the Attachments window.
Help	Display online help.

If you have added any attachments, the number of attachments will be displayed on the **Attachments** button (the red circle is known as a "Badge").

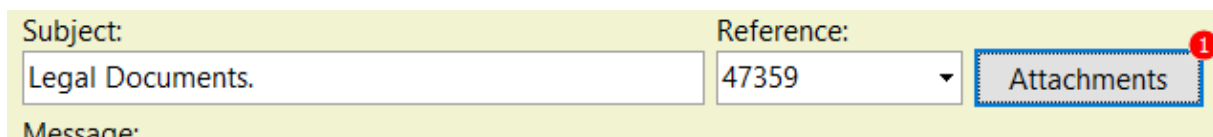

Message Text

The **Message** field is where you can enter additional information.

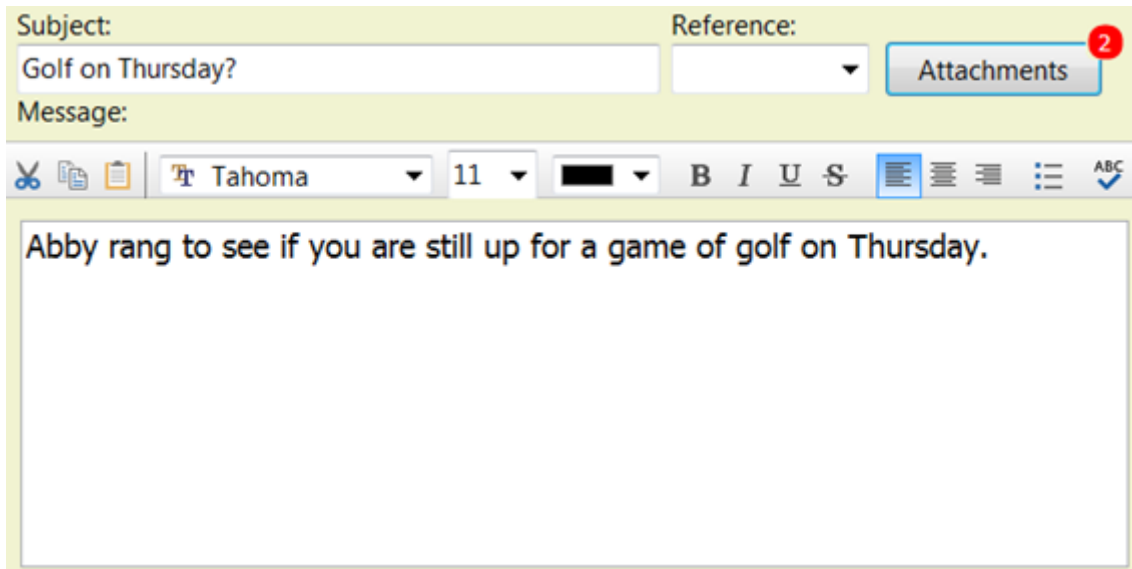

This field has its own toolbar so that you can customize the appearance of the text you enter. The usual buttons are there such as Cut, Copy and Paste, as well as buttons to manipulate the font.

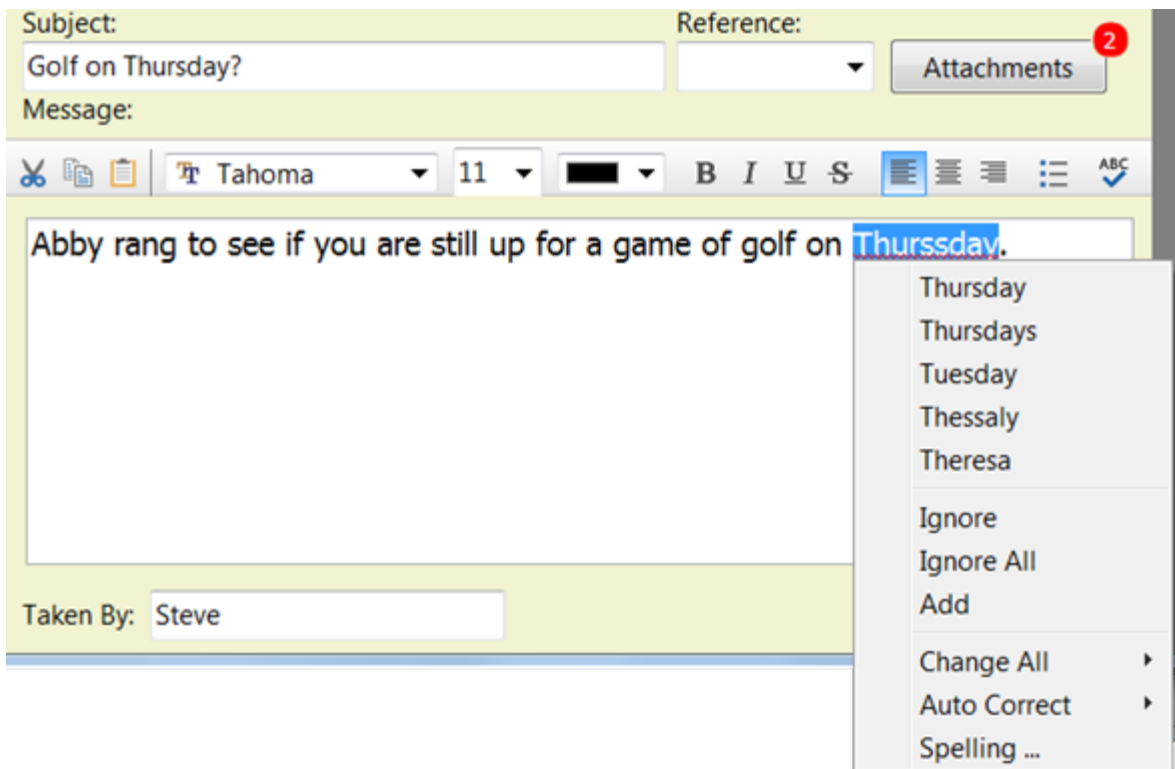

There is also a spell checker to check your spelling. You can either click the Spell Check button on the message toolbar, or you can use Live Spell Check (you will see red squiggly lines under words that may be mis-spelt).

Options Button

The **Options** button at the bottom of the phone message form has 3 options.

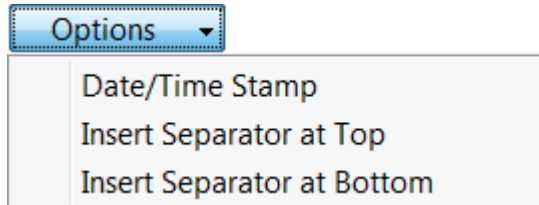

<p>Date/Time Stamp</p>	<p>Inserts a Date and Time stamp with the logged in user's name.</p> <p>The screenshot shows the message form with the 'Options' button selected. The message content area contains the text: [14/10/2016 5:59:17 PM][Jane]: </p>
<p>Insert Separator at Top</p>	<p>Inserts a line above the current line.</p> <p>The screenshot shows the message form with the 'Options' button selected. The message content area contains the text: *****[14/10/2016 6:06:51 PM][Jane]:</p> <p>The separator character and length can be set under View/Preferences/Messages-3.</p>

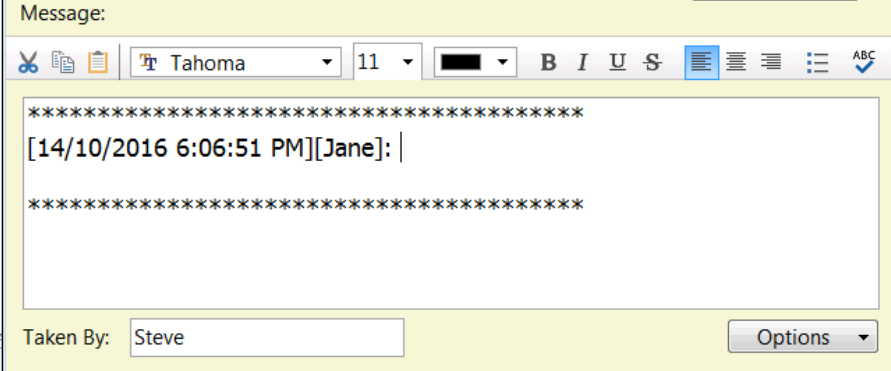
<p>Insert Separator at Bottom</p>	<p>Inserts a line below the current line.</p>  <p>The separator character and length can be set under View/Preferences/Messages-3.</p>
--	---

Sending the Message

All that's left to do is click the **Send** button.

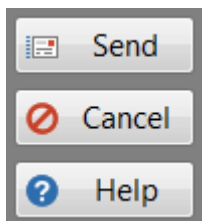

Phone Messages (Outgoing)

This message form is used to log details of outgoing calls. Whenever you call someone, you can enter the details of the call in an outgoing message.

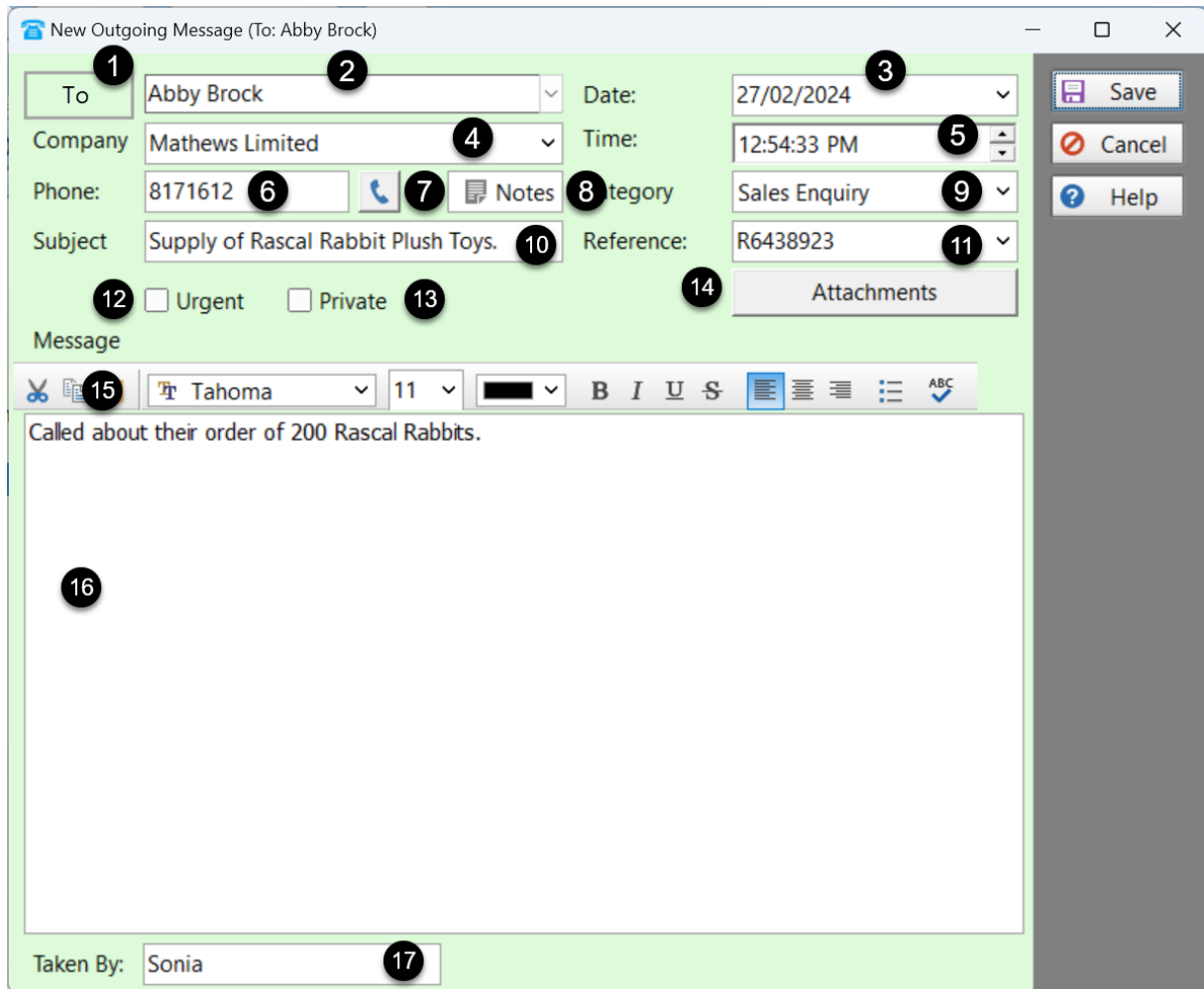

1	Click the To button to look up the details for the person you are calling (if they are in the Address Book).
2	Type in the person's name. If they exist in the Address Book PhonePad will fill in the details for you.
3	The date field is automatically filled in for you but you can change it if needed.
4	This is the company the person is from. If the person isn't from a company you can leave this blank.
5	The time field is automatically filled in for you but you can change it if needed.

6	Enter the person's phone number. If the person already exists in the system then this will be pre-filled for you, but you can change it if the number is different.
7	You can click this button to select other phone numbers for this person.
8	View or add notes for this person.
9	You can assign this call to a Category (if your administrator has set them up).
10	Subject of the message.
11	A free form text field that can also be used for other messages. When you enter text in this field, it can be accessed for other messages (by any user).
12	If checked, the message will be marked as Urgent.
13	If checked, any user who has access to your folders will not be able to read the content of the message.
14	You can add attachments to messages. If there is an attachment, the number of attachments will be shown in a red circle (which is known as a "Badge").
15	Toolbar for the message text.
16	The message text is where you enter additional details of the call.
17	Your name will be entered here by PhonePad when you create a new message. This cannot be changed.

Logging an Outgoing Call

To log an outgoing phone call, click the **New Outgoing Call** button on the toolbar, or select **New Outgoing Call** from the **File** menu, or press the **<ctrl> <insert>** keys on your keyboard.

Message Date and Time

PhonePad will automatically fill in the current date and time for you. You can change these if needed.

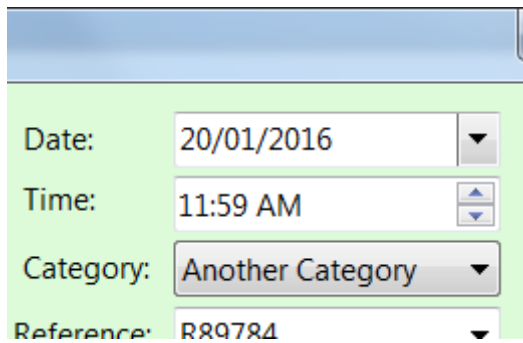

A screenshot of a message form with a light green background. It contains four fields: 'Date:' with a text input containing '20/01/2016' and a dropdown arrow; 'Time:' with a text input containing '11:59 AM' and up/down arrow buttons; 'Category:' with a dropdown menu showing 'Another Category'; and 'Reference:' with a text input containing 'R89784' and a dropdown arrow.

To change the date, you can either type it in or select it from the drop-down calendar.

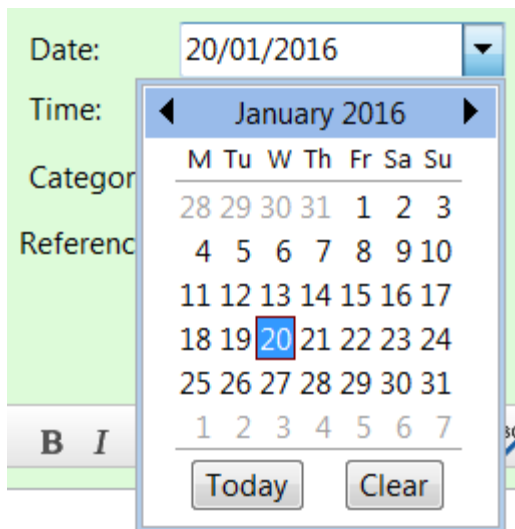

A screenshot showing the date selection calendar. The 'Date:' field is set to '20/01/2016'. A calendar pop-up is open, showing 'January 2016'. The calendar grid has days of the week (M, Tu, W, Th, Fr, Sa, Su) and dates. The date '20' is highlighted in blue. Below the calendar are 'Today' and 'Clear' buttons. The background shows parts of the 'Time:', 'Category:', and 'Reference:' fields.

To edit the time, use the up and down arrows keys on your keyboard to change the hour, minutes and am/pm. You can also use the up and down arrow buttons in the **Time** field.

Use the left and right arrow keys to move between hours, minutes and am/pm.

Recipients Name

Type the name of the caller in the **To** field. PhonePad will perform an incremental search to try to locate the caller's name.

New Outgoing Message (To: Abby Brock)

To: Abby Brock

Company: Aaron Wheeler
Aaron Wheeler

Phone: Aaron Wheeler

Subject: Aaron Wheeler
Abby Barlow
Abby Barlow
Abby Barlow

Message: Abby Brock

If the recipient appears in the list, select their name and press the **<enter>** key. If the recipient isn't in the list just type in their name and press the **<enter>** key.

You can also select a recipient by clicking on the **To** button. The **To Lookup** window will appear.

Recipient Lookup

Search text: abby Fullname Search

To	Company	City	State	Phone
Abby Barlow	Snyder and Sons			8821351
Abby Brock	Mathews Limited			8171612
Abby Brooks	Skinner Inc			6432363
Abby Delaney	Mcdonald Pty Ltd			9884925

OK Cancel Help

To Abby Brock **Company:** Mathews Limited

Address 1: **Address 2:**

City: **State:** **Postal Code:**

Country: **Phone:** 8171612

Alt. Phone: **Fax:**

Cell/Mobile: **Email:**

Enter your **Search Text** and select the fields you want to search, then click the **Search** button.

When you select a name from the list their details will appear below so you can verify its the right person. Click **OK** to select the caller.

Company

If the caller is from an organization you can select a **Company** from a list of companies known to PhonePad (via the Address Book). As you type in a name PhonePad will perform an incremental search, narrowing down the company names to match what you type in. Press the <enter> key to select a company.

If the name doesn't exist you can just type it in.

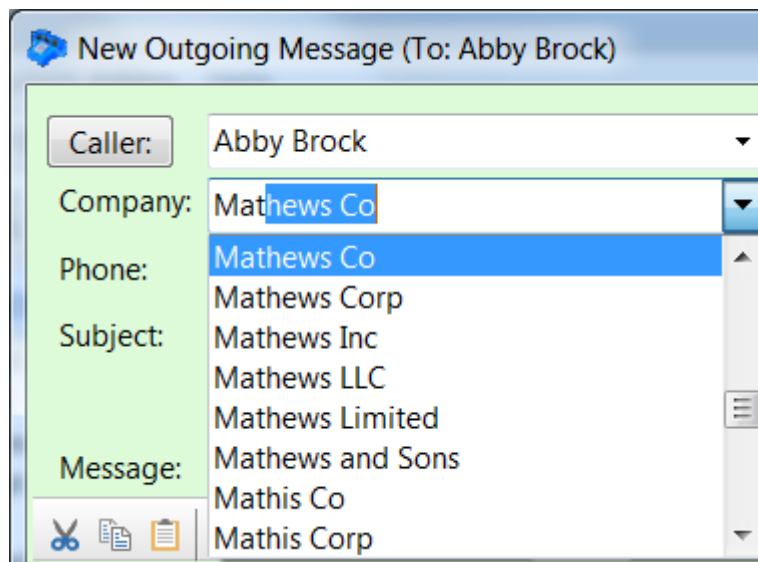

If the caller has called before then the Company name will be automatically filled in for you, however, you can change it if required.

Phone Number

Enter the phone number in the **Phone** field. If the caller you selected is already in the system this field will be pre-filled for you.

New Outgoing Message (To: Abby Brock)

Caller: Abby Brock

Company: Mathews Limited

Phone: 8171612

Subject: RE:

If you click the button with the telephone icon, you can select additional phone numbers if there are any.

New Outgoing Message (To: Abby Brock)

Caller: Abby Brock

Company: Mathews Limited

Phone: 8171612

Subject: Bus Phone 8171612
Bus Alt Phone 8171614
Bus Fax
Bus Cell/Mobile 8894563
Home Phone 8795641
Home Alt Phone

Message:



Normally the **Phone** field is a free-form text field, which means you can enter phone numbers in any format you like. However, if your PhonePad administrator has specified a phone number format for the Phone field then you will be restricted to that format.

Notes

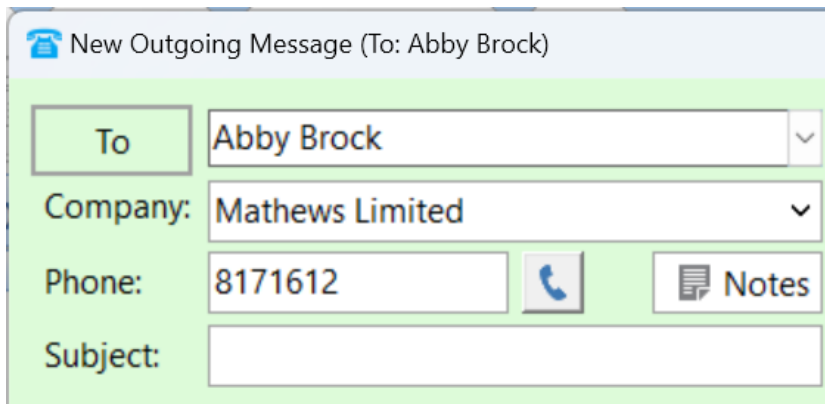
You can optionally enter Notes for this person.



The screenshot shows a 'New Outgoing Message' dialog box for Abby Brock. The fields are as follows:

To	Abby Brock		
Company:	Mathews Limited		
Phone:	8171612		 Notes
Subject:			

Just click the **Notes** button. If there are any notes for the recipient they will be displayed. You can also add notes from this screen.

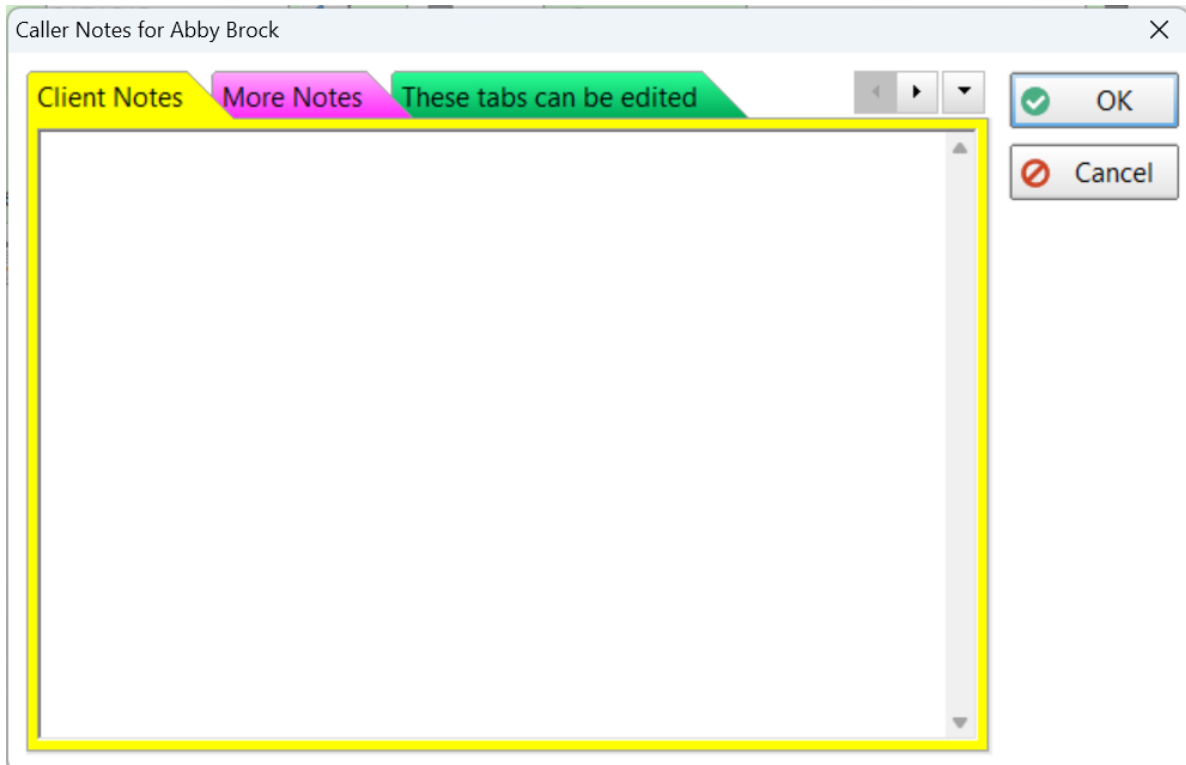

The screenshot shows the 'Caller Notes for Abby Brock' dialog box. It features three tabs: 'Client Notes' (yellow), 'More Notes' (purple), and 'These tabs can be edited' (green). The main area is a large text input field with a vertical scrollbar. On the right side, there are 'OK' and 'Cancel' buttons.

This is the same window that is display for Caller Notes when taking a incoming phone call. The notes are stored in the Address Book for the recipient.

There are 10 tabs available for notes. The names and colors of the tabs can be changed under **System Rules** by System Administrators.

Category

If your PhonePad administrator has created some categories, you can select a **Category** from the drop-down list.

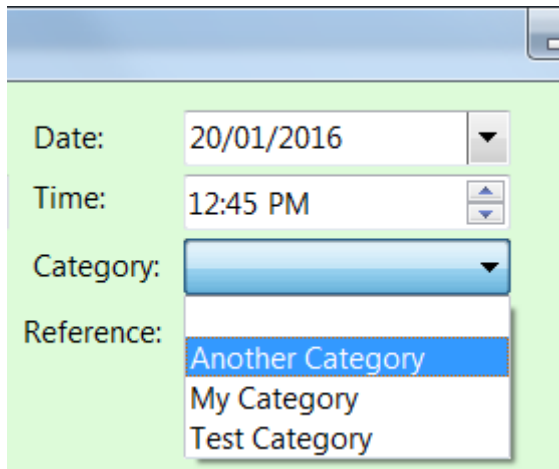

The screenshot shows a form with the following fields:

- Date: 20/01/2016
- Time: 12:45 PM
- Category: A dropdown menu is open, showing three options: "Another Category" (highlighted), "My Category", and "Test Category".
- Reference: (empty)

Subject

The **Subject** is the subject of the phone call, although you can enter whatever you like in this field. .

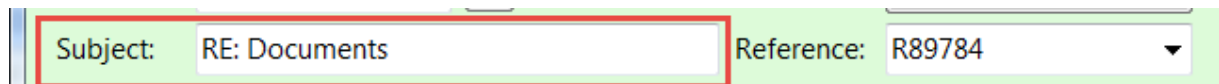

The screenshot shows a form with the following fields:

- Subject: RE: Documents
- Reference: R89784

This field may be prefixed with some text that has been set up by your PhonePad administrator.

Reference

The Reference field is a free-form text field that can contain whatever text you want. Its purpose is to make the text available for future messages. When you enter text in this field, PhonePad will remember it so that the next time you create an incoming or outgoing phone message you can select the text from the drop-down list.

The text in the drop-down list is available for *all* users to access.

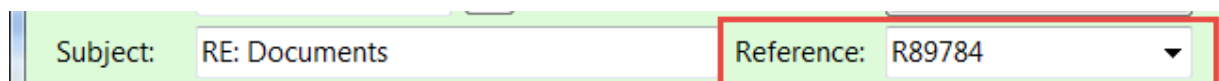

The screenshot shows a form with the following fields:

- Subject: RE: Documents
- Reference: R89784

Possible uses for this field are: patient numbers, client numbers, file numbers and so on.

Message Options

There are a couple of options you can use with Outgoing Messages.

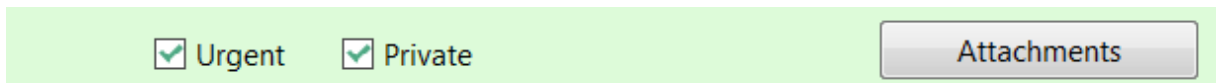

Private	When checked, only the recipients and sender of the message can view it. Anyone else who has access to your Inbox and folders will not be able to read the message unless they are also a recipient.
Urgent	When checked the message will be marked as Urgent.

Attachments

You can attach up to 5 attachments to each message.

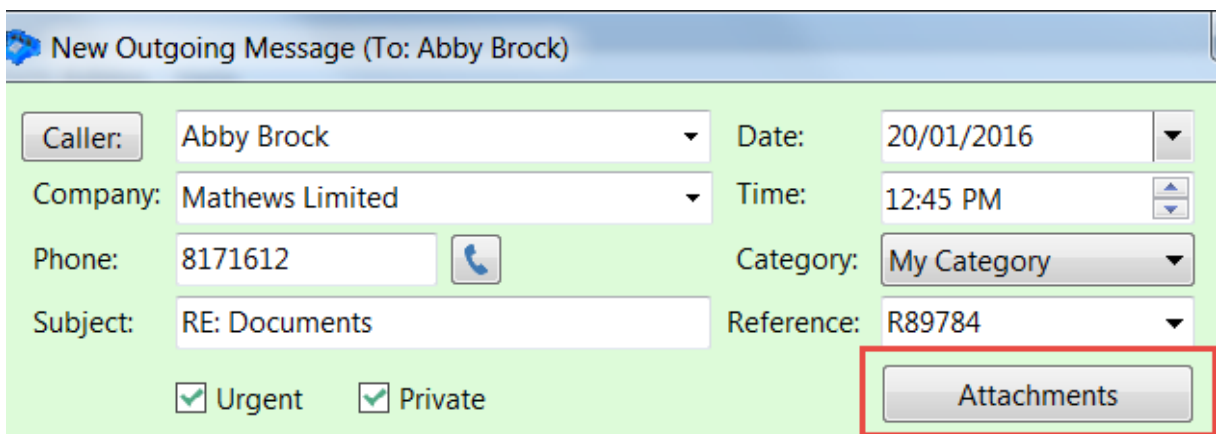

Click the **Attachments** button.

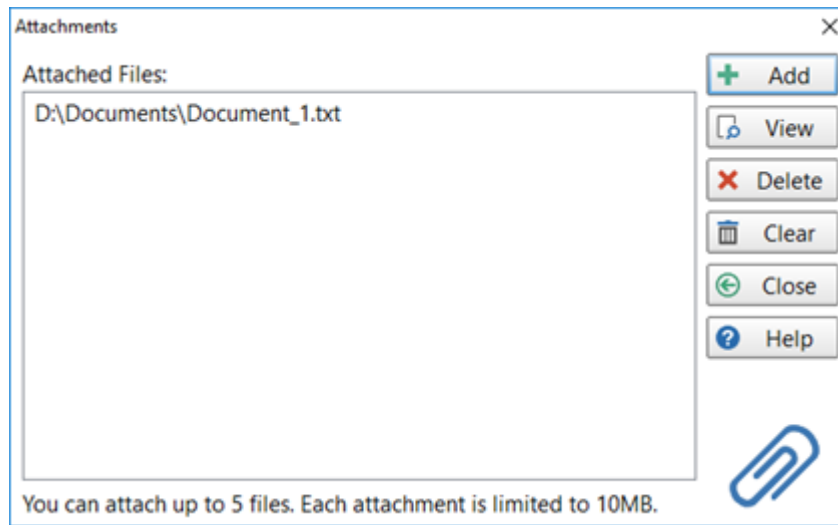

Add	Add an attachment. You can add up to 5.
View	View the selected attachment.
Delete	Delete the selected attachment.
Clear	Delete all attachments.
Close	Close the Attachments window.
Help	Display online help.

If you have added any attachments, the number of attachments will be displayed on the **Attachments** button (the red circle is known as a "Badge").

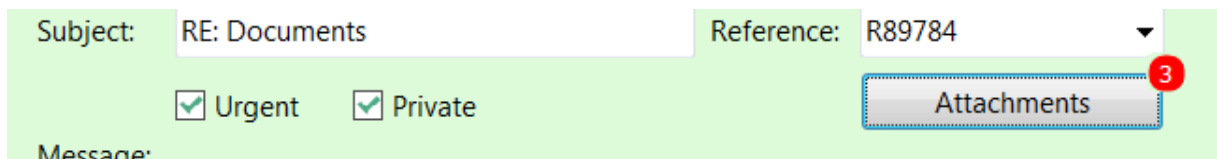

Message Text

The **Message** field is where you can enter additional information.

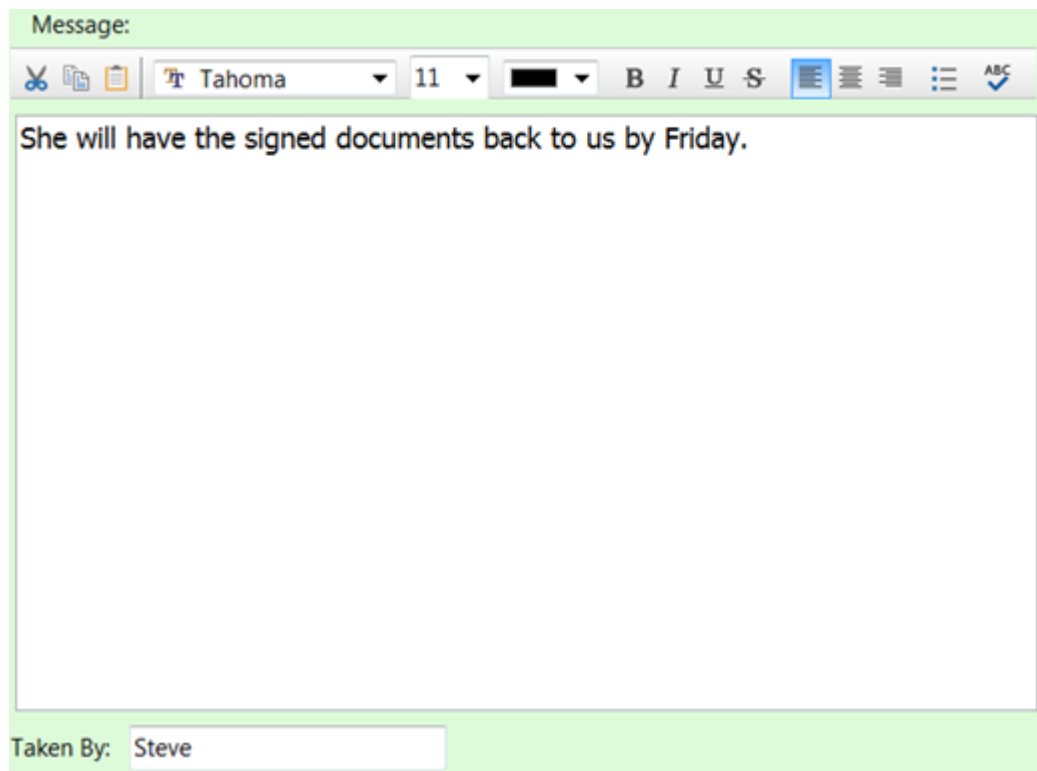

This field has its own toolbar so that you can customize the appearance of the text you enter. The usual buttons are there such as Cut, Copy and Paste, as well as buttons to manipulate the font.

There is also a spell checker to check your spelling. You can either click the Spell Check button on the message toolbar, or you can use Live Spell Check (you will see red squiggly lines under words that may be mis-spelt).

Saving the Message

All that's left to do is click the **Save** button. The message will be saved in your Outgoing folder.

Text Messages

Text messages are messages that are **not** phone messages. They are generally used for intra-office communications. There are no callers in text messages. They are messages sent between users.

Do not confuse text messages with SMS text messages that you send to cell/mobile phones. Although they sound similar, they are completely different.

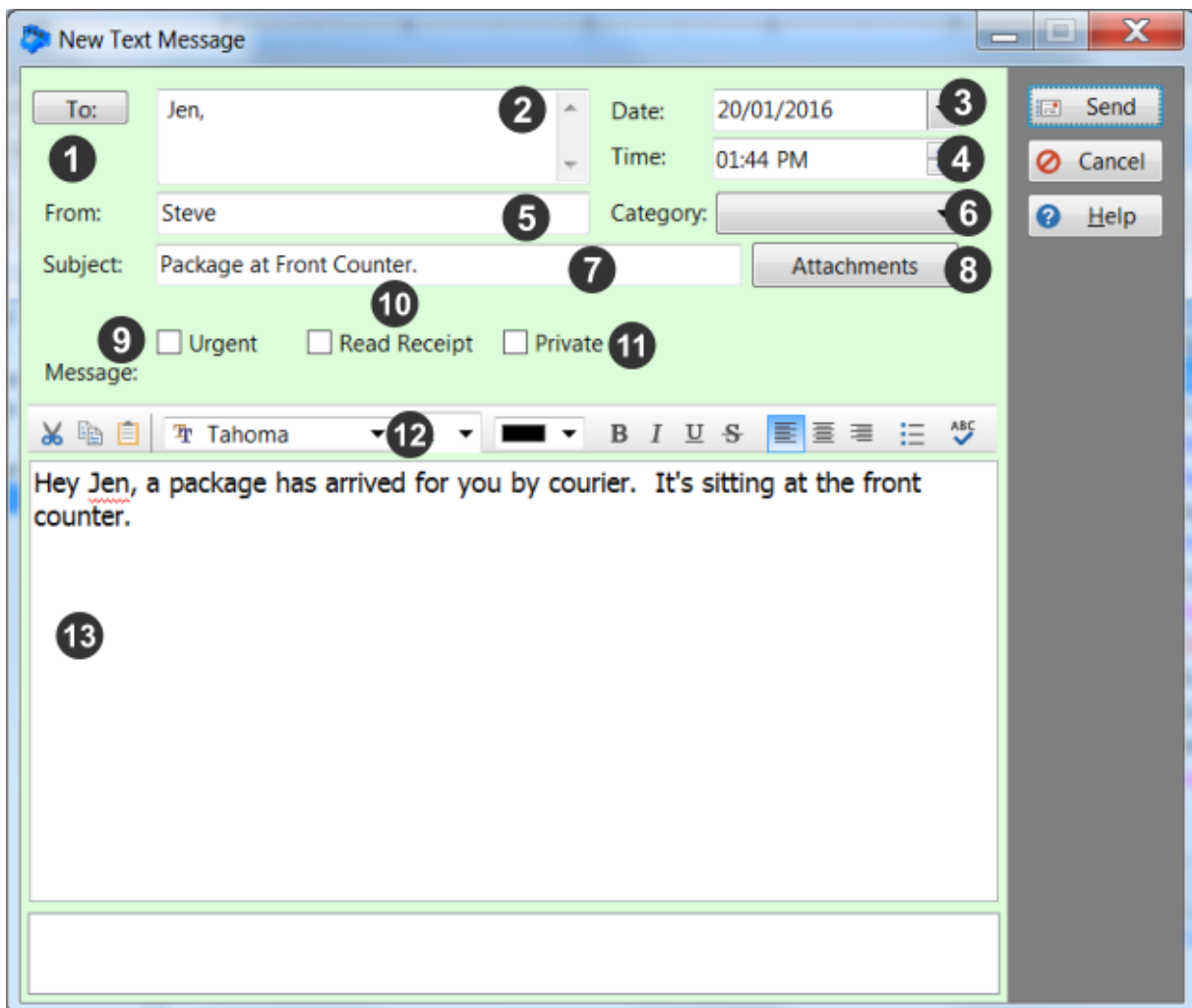

1	Click the To button to display a list of all PhonePad users. Select the users you want the message sent to.
2	As an alternative to clicking the To button, you can just type the user names in this field. It will automatically do an incremental search and find the user's name for you. Press <ENTER> to select a name.
3	The date field is automatically filled in for you but you can change it if needed.
4	The time field is automatically filled in for you but you can change it if needed.

5	Your name will be entered here by PhonePad when you create a new message. This cannot be changed.
6	You can assign this call to a Category (if your administrator has set them up).
7	Subject of the message.
8	You can add attachments to messages. If there is an attachment, the number of attachments will be shown in a red circle (which is known as a "Badge").
9	If checked, the message will be marked as Urgent.
10	If checked, you will receive a message when the recipient/s read the message.
11	If checked, any user who has access to your folders will not be able to read the content of the message unless they are one of the recipients.
12	Toolbar for the message text.
13	The message text is where you enter additional details of the call.

Creating a Text Message

To log an outgoing phone call, click the **New Text Message** button on the toolbar, or select **New Text Message** from the **File** menu, or press the **<alt> <insert>** keys on your keyboard.

Message Date and Time

PhonePad will automatically fill in the current date and time for you. You can change these if needed.

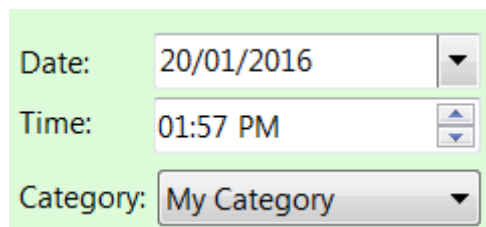

The image shows a screenshot of a form with three fields: 'Date' with the value '20/01/2016', 'Time' with the value '01:57 PM', and 'Category' with the value 'My Category'. Each field has a small arrow icon indicating it is a drop-down menu.

To change the date, you can either type it in or select it from the drop-down calendar.

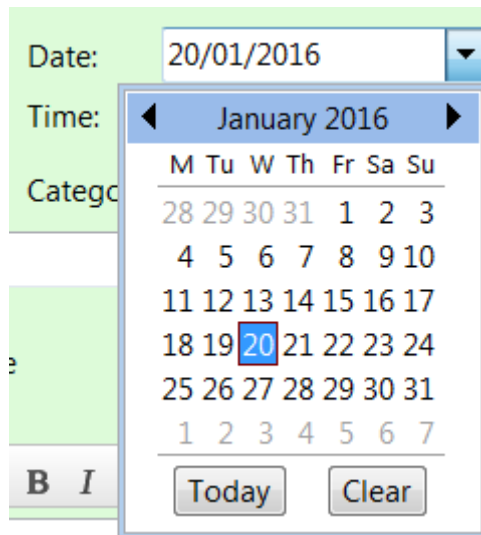

To edit the time, use the up and down arrows keys on your keyboard to change the hour, minutes and am/pm. You can also use the up and down arrow buttons in the **Time** field.

Use the left and right arrow keys to move between hours, minutes and am/pm.

Recipients

The first step is to address the message to at least one person.

The fastest way to do this is to type in the **To** field.

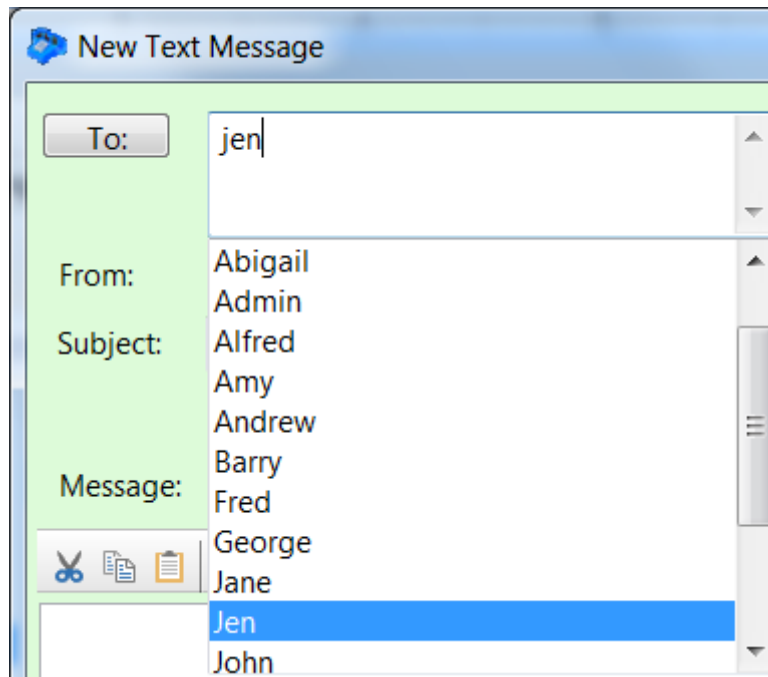

As you type in a name, PhonePad will drop down a list of users and perform an incremental search. Press **<enter>** to select a user. You can add additional users if you want.

Names beginning with a # are groups, eg. #Service. When you send a message to a group it will be sent to everyone in the group.

You can also select names by clicking the **To** button. The **Users** tab allows you to select users while the **Groups** tab allows you to select groups. You can expand a group to see who the members are.

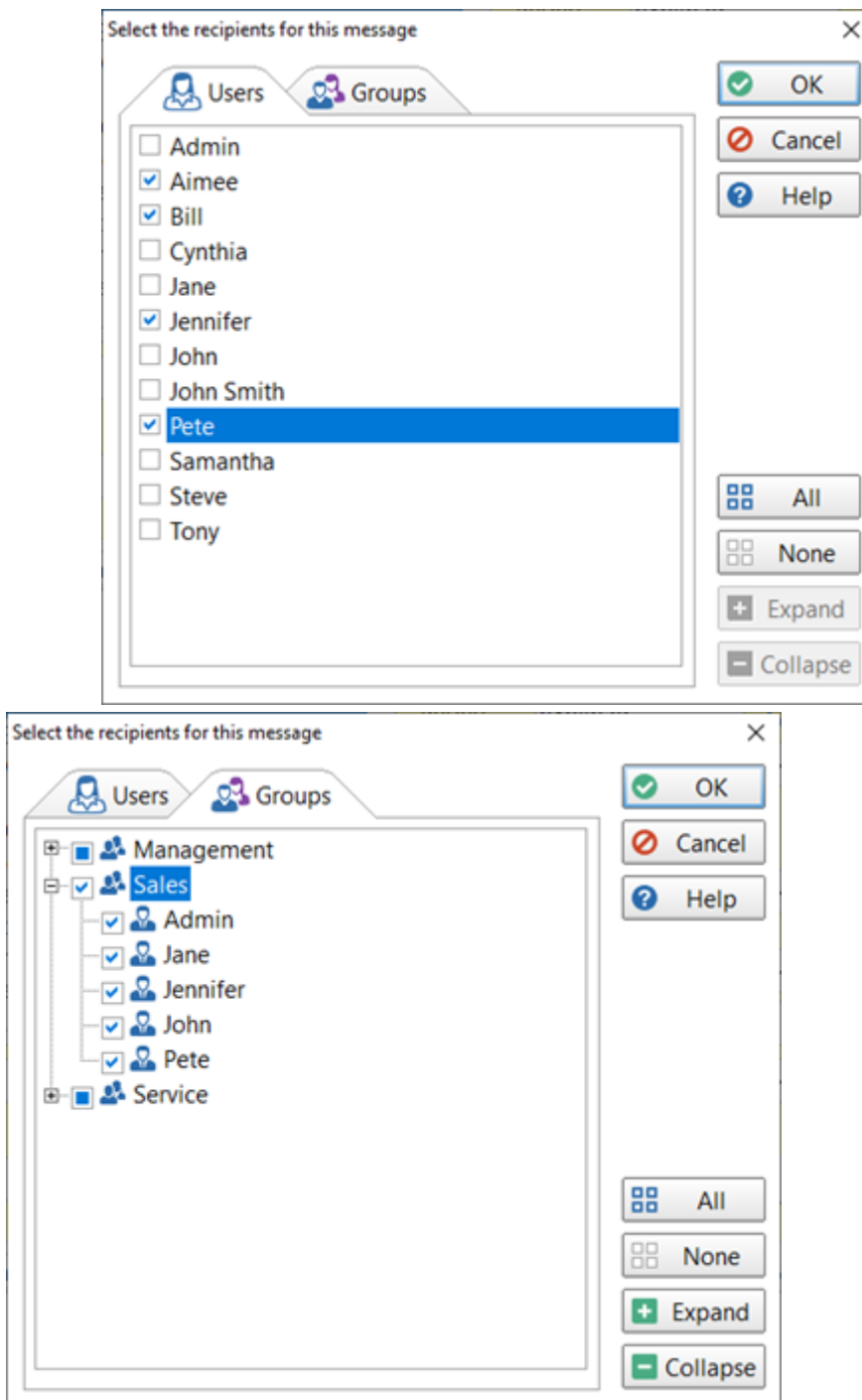

Category

If your PhonePad administrator has created some categories, you can select a Category from the drop-down list.

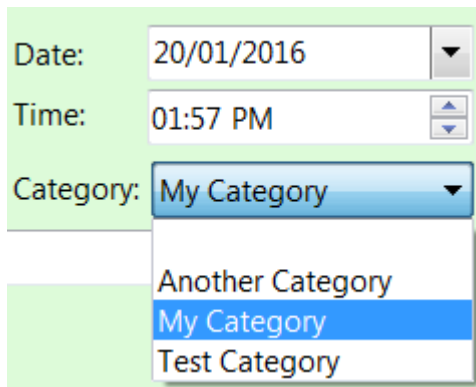

Date: 20/01/2016

Time: 01:57 PM

Category: My Category

- Another Category
- My Category
- Test Category

Subject

The **Subject** is the subject of the phone call, although you can enter whatever you like in this field. .

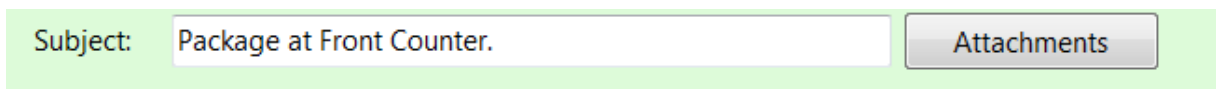

Subject: Package at Front Counter. Attachments

This field may be prefixed with some text that has been set up by your PhonePad administrator.

Attachments

You can attach up to 5 attachments to each message.

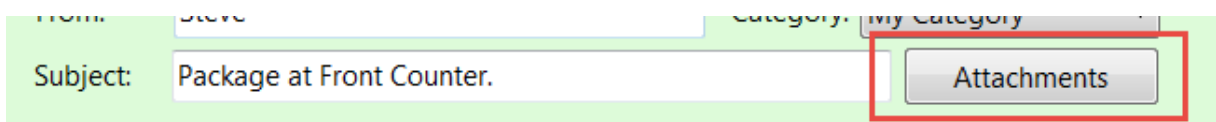

From: Steve Category: My Category

Subject: Package at Front Counter. Attachments

Click the **Attachments** button.

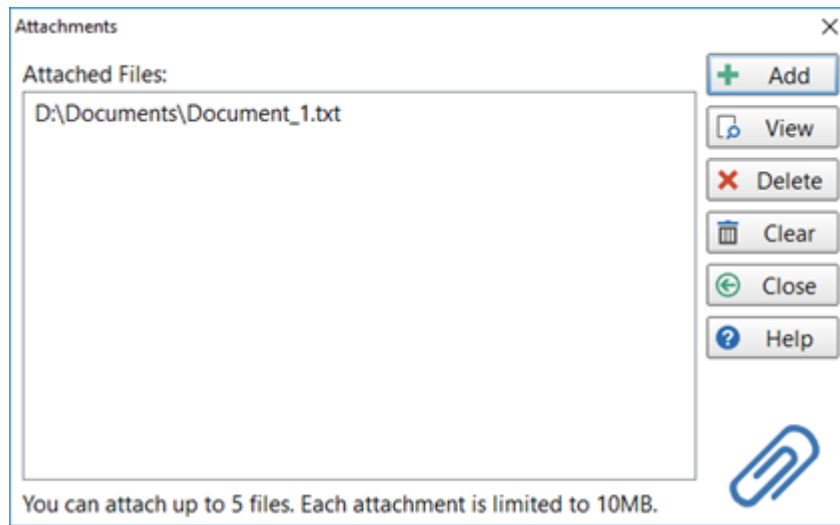

Add	Add an attachment. You can add up to 5.
View	View the selected attachment.
Delete	Delete the selected attachment.
Clear	Delete all attachments.
Close	Close the Attachments window.
Help	Display online help.

If you have added any attachments, the number of attachments will be displayed on the **Attachments** button (the red circle is known as a "Badge").

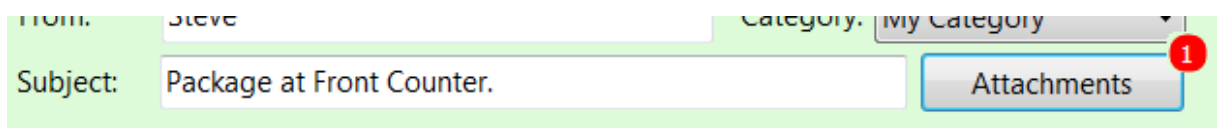

Message Options

As with other message types, there are some options you can use with Text Messages.



Urgent	When checked the message will be marked as Urgent.
Read Receipt	When checked, you will receive a receipt message when a recipient has read the message.
Private	When checked, only the recipients and sender of the message can view it. Anyone else who has access to your Inbox and folders will not be able to read the message unless they are also a recipient.

Message Text

The **Message** field is where you can enter additional information.

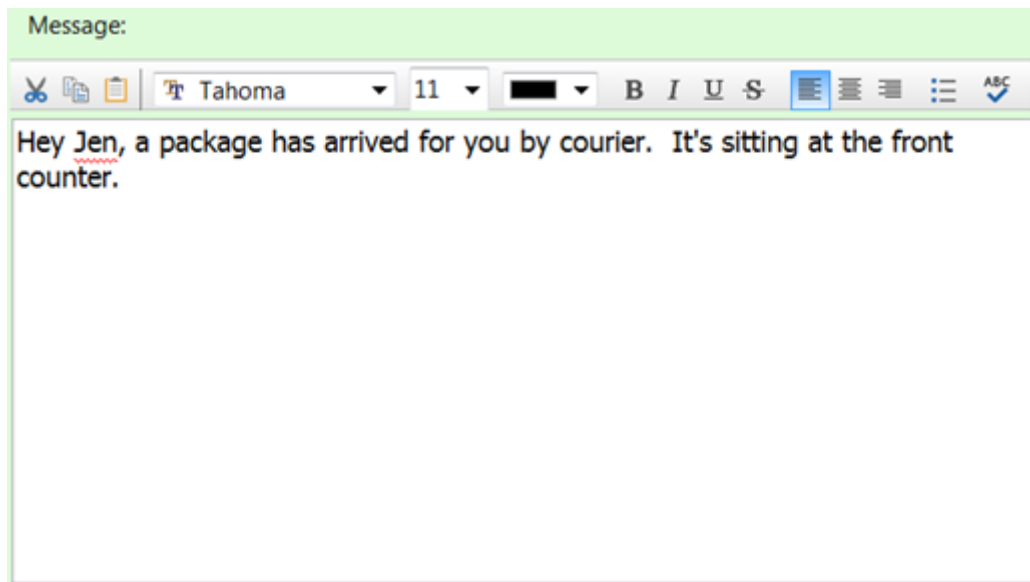

This field has its own toolbar so that you can customize the appearance of the text you enter. The usual buttons are there such as Cut, Copy and Paste, as well as buttons to manipulate the font.

There is also a spell checker to check your spelling. You can either click the **Spell Check** button on the message toolbar, or you can use **Live Spell Check** (you will see red squiggly lines under words that may be mis-spelt).

Sending the Message

All that's left to do is click the **Send** button.

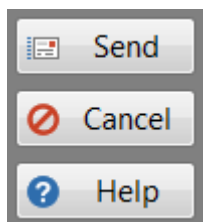

Viewing Messages

Viewing Phone Messages (Incoming)

Select the phone message from the message list and click the **View** button on the **Home** tab of the toolbar, or select **View Message** from the **File** menu, or double-click on the message.

The phone message will be displayed.

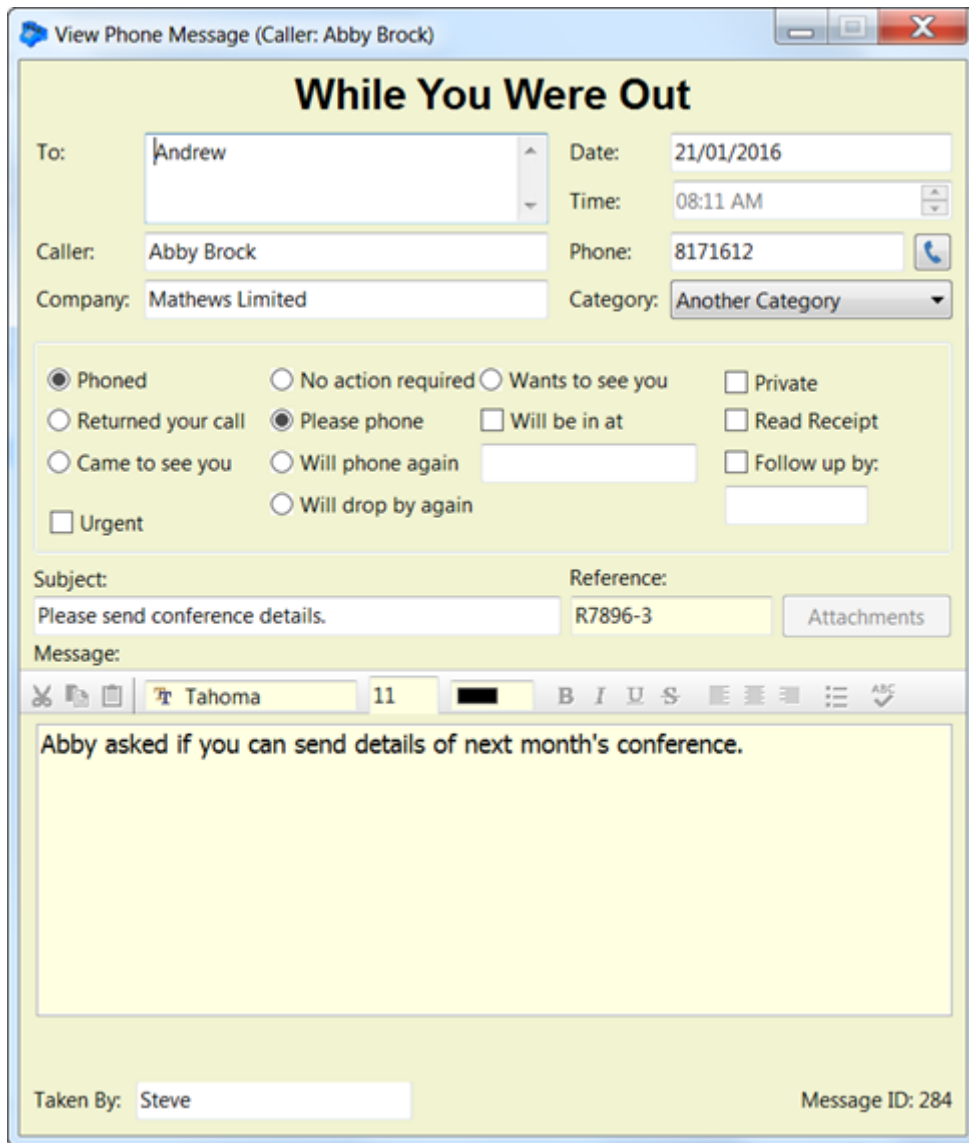

If you click on the button with the phone icon, you can view alternative phone numbers for the caller.

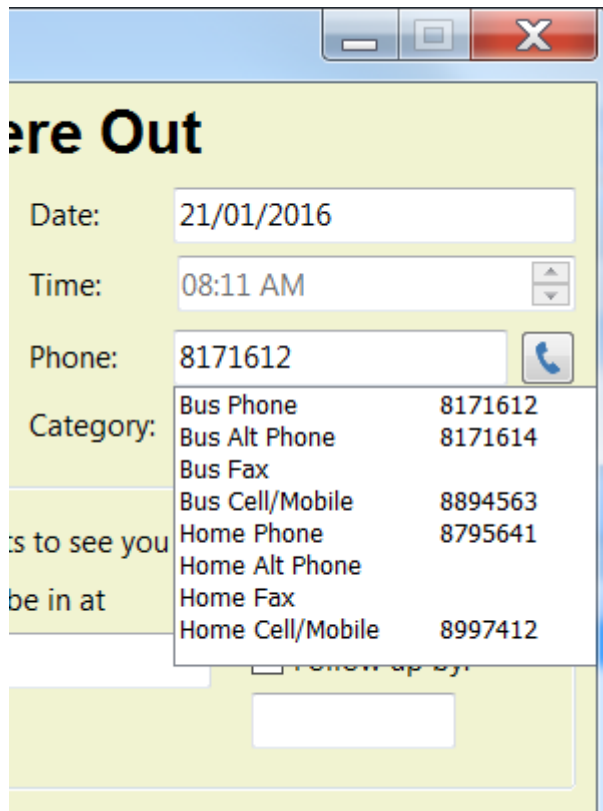

If there is follow up action on the message, this will be displayed at the top of the message window.

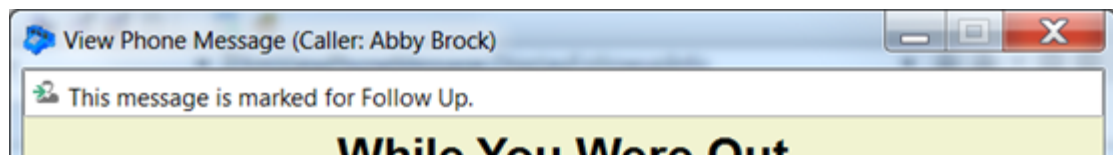

Message details cannot be changed unless your PhonePad administrator has allowed this.

 Every message has a unique Message ID, displayed in the right-bottom corner. You can use this to identify messages.

Viewing Phone Messages (Outgoing)

Select the phone message from the message list and click the **View** button on the **Home** tab of the toolbar, or select **View Message** from the **File** menu, or double-click on the message.

The outgoing message will be displayed.

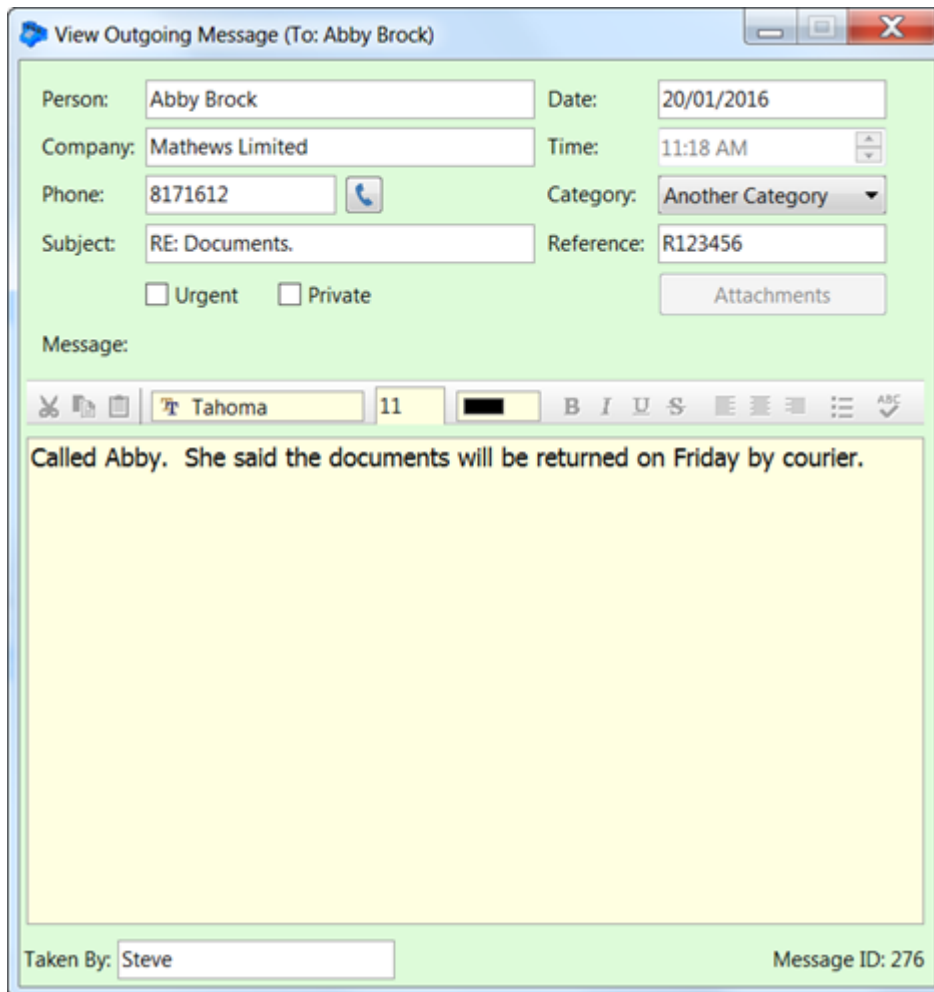

If there is follow up action on the message, this will be displayed at the top of the message window.

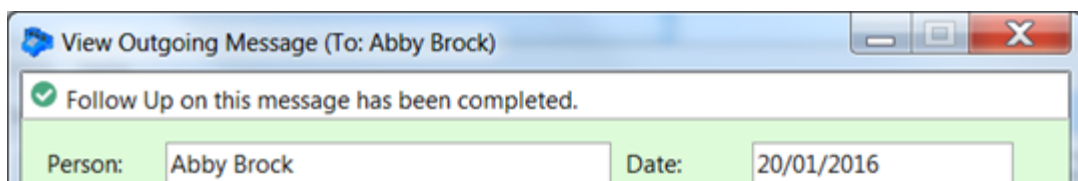

 Every message has a unique Message ID, displayed in the right-bottom corner. You can use this to identify messages.

Viewing Text Messages

Select the text message from the message list and click the **View** button on the **Home** tab of the toolbar, or select **View Message** from the **File** menu, or double-click on the message.

The text message will be displayed.

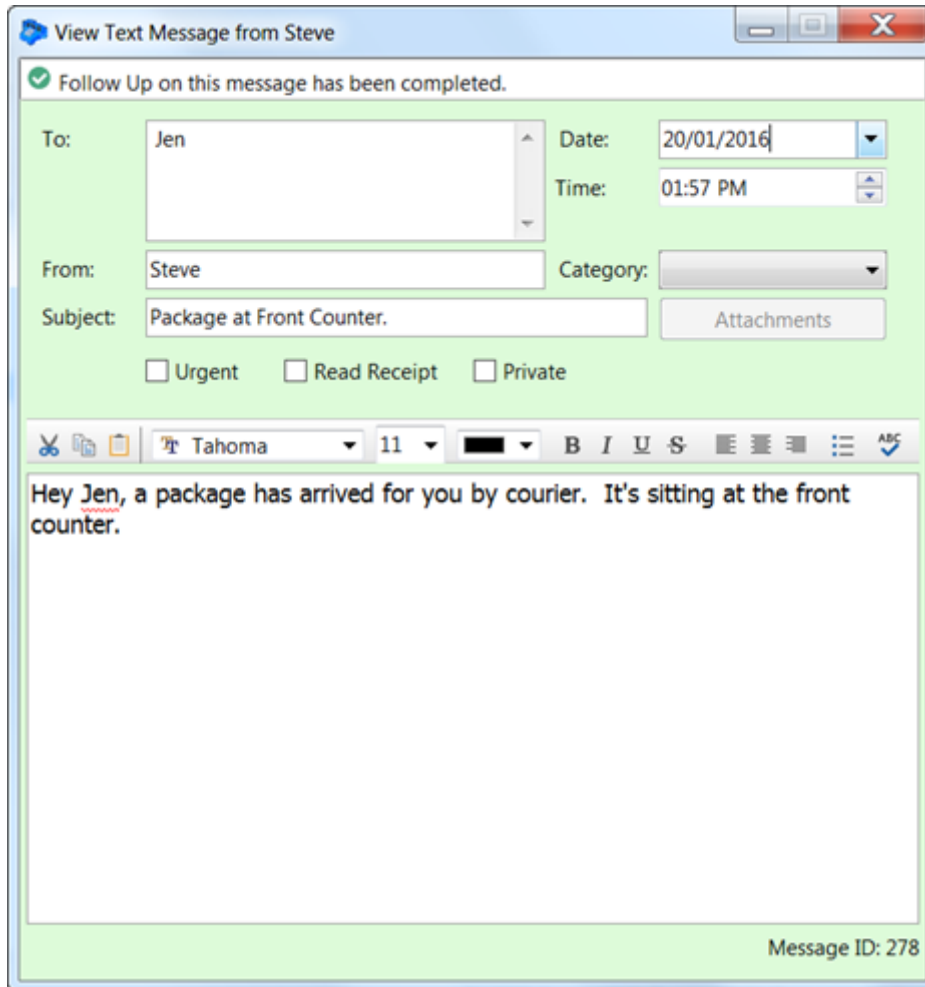

If there is follow up action on the message, this will be displayed at the top of the message window.

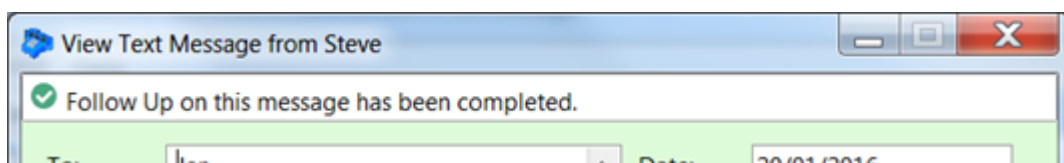



Every message has a unique Message ID, displayed just below the Attachments button. You can use this to identify messages.

Viewing Message Read Receipts

Select the message receipt from the message list and click the **View** button on the **Home** tab of the toolbar, or select **View Message** from the **File** menu, or double-click on the message.

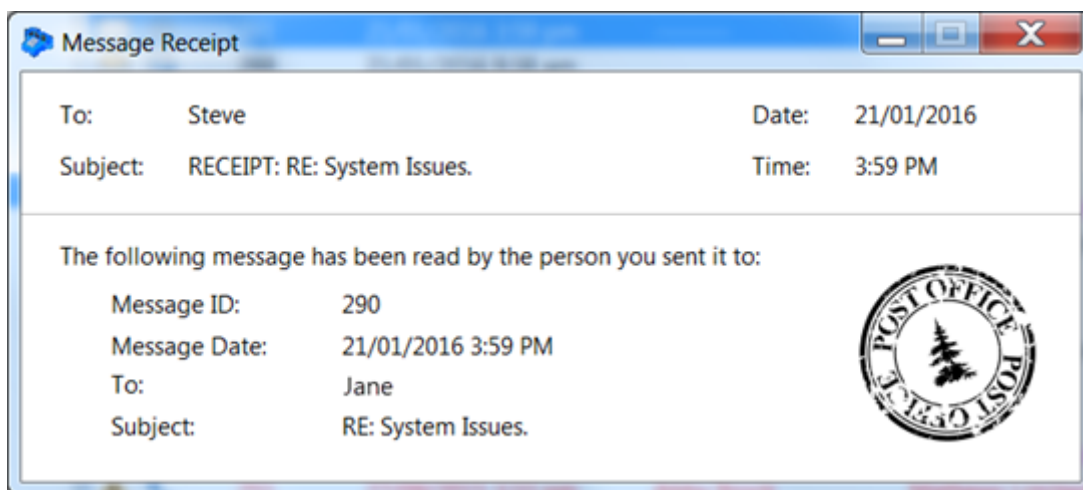

This message types are for phone and text messages sent via PhonePad to other users.

Viewing Email Replies

Select the email reply message from the message list and click the **View** button on the **Home** tab of the toolbar, or select **View Message** from the **File** menu, or double-click on the message.

The email reply message will be displayed.

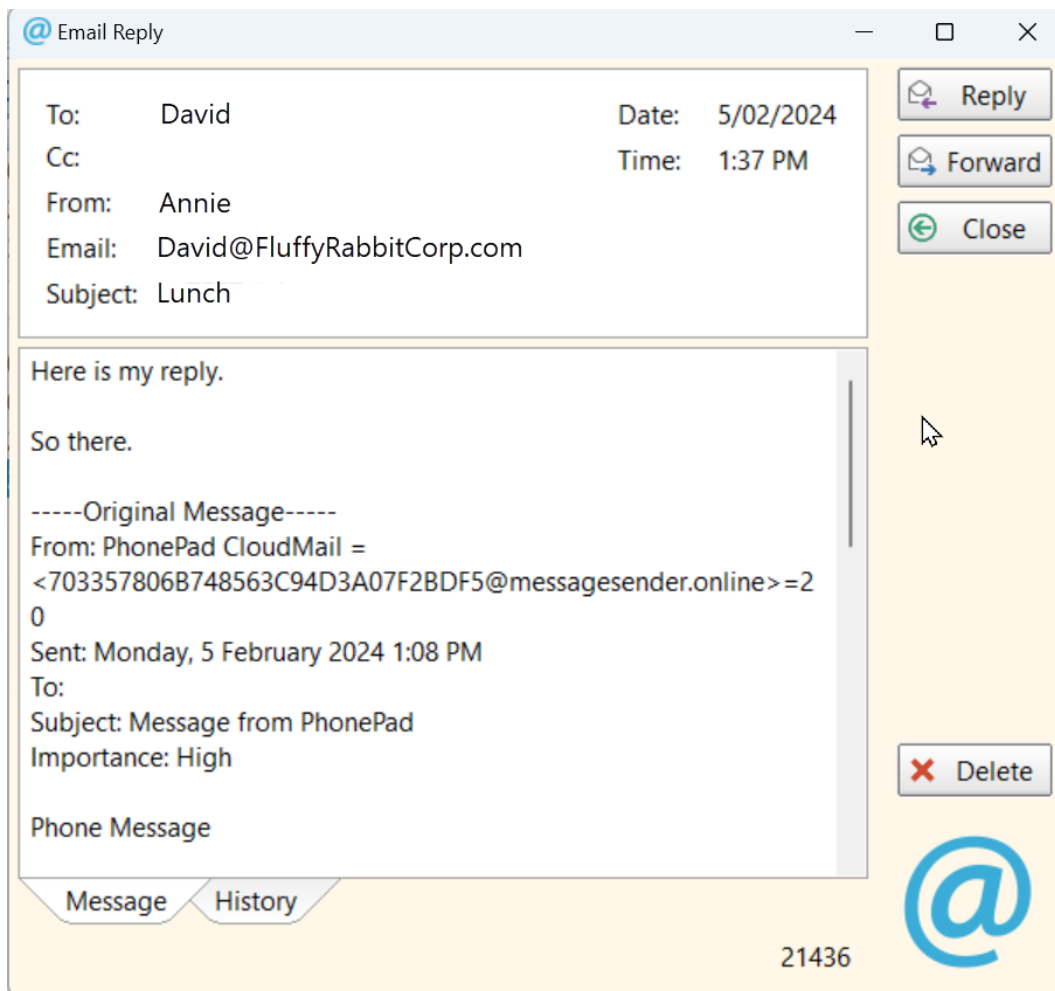

Viewing Email Read Receipts

The Automatic Message Forwarding feature can automatically forward phone and text messages to email addresses.

If you have checked the **Read Receipt** checkbox in a message before sending it, you can get a **Read Receipt** back from the email system when the recipient reads the email.

Please note: This option has to be enabled by a System Administrator under MessageSender settings.

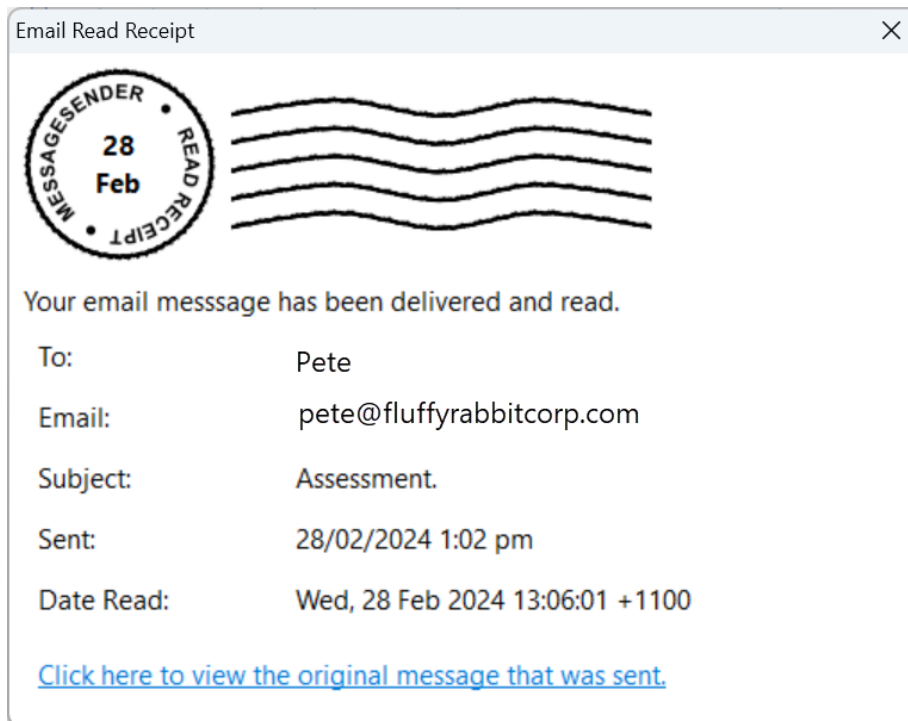

Email Read Receipts are different from Message Read Receipts. Email Read Receipts are received when a user has their messages forwarded to an email address using the Automatic Message Forwarding feature.

Viewing Email Delivery Failure Messages

Sometimes emails cannot be delivery for one reason or another. In these cases you will receive an **Email Delivery Failed** message in your Inbox.



In the above example the email address is incorrect.

You can view the original message that was sent by clicking *Click here to view the original message that was sent.*

You can also view the **email message header**. Unless you know how to read these headers, it may not be that useful to you.

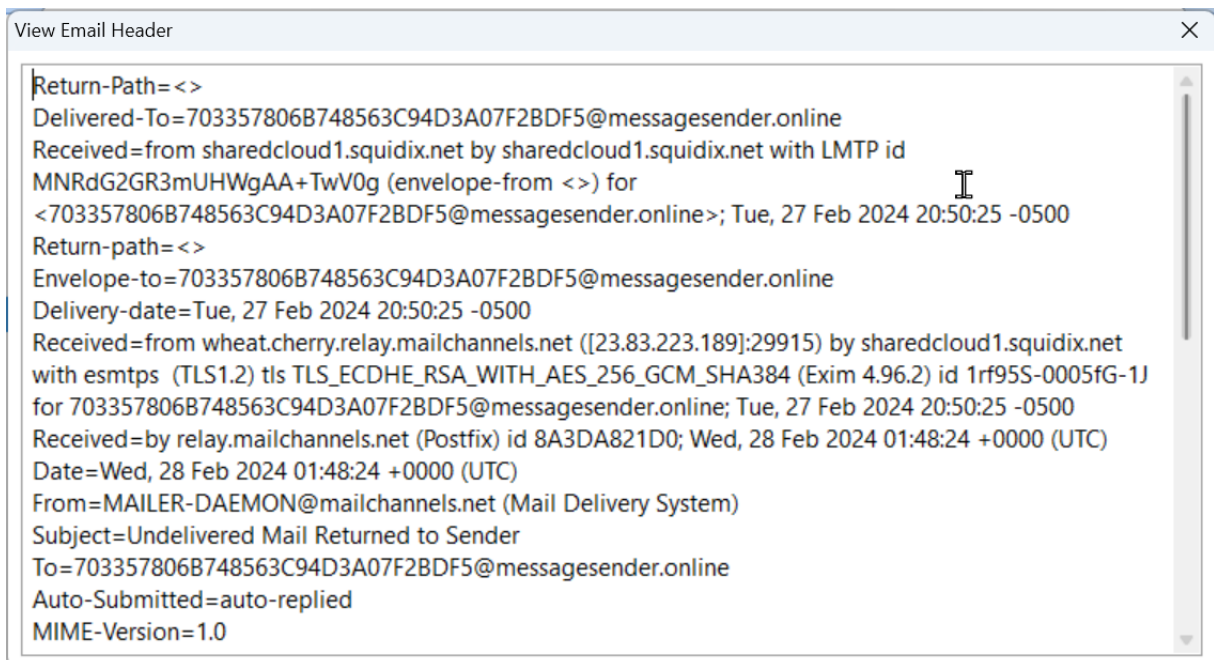

Viewing Attachments

Phone, text and outgoing messages can all have attachments. If a message has one or more attachments the number of attachments will be shown on the **Attachments** button.

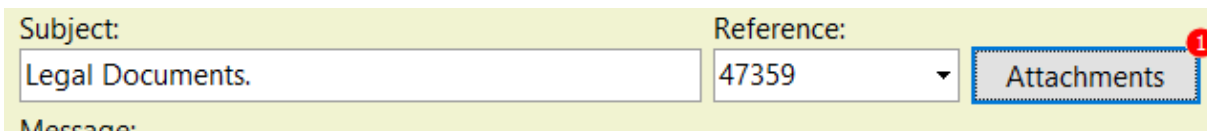

Click the **Attachments** button to view the list of attachments.

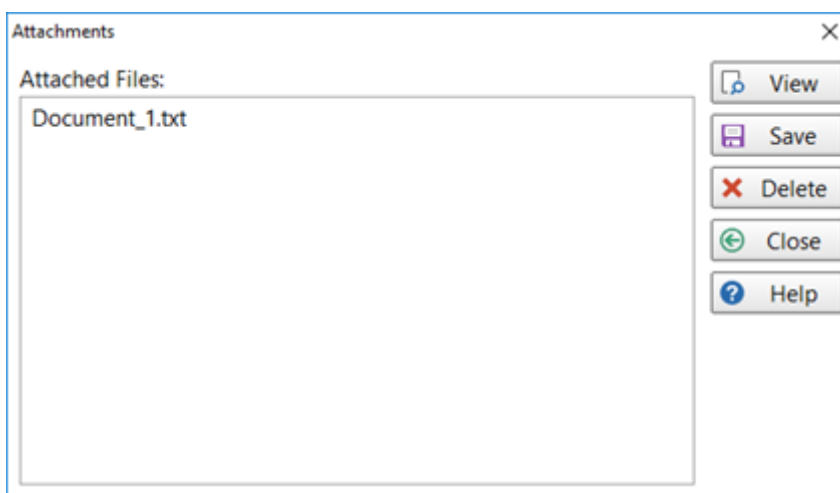

In this example there is one attachment.

View	Select an attachment and click the View button. Windows will attempt to open the attachment using the default application associated with the file type.
Save	Save the selected attachment to a folder.
Delete	Delete the selected attachment.
Close	Close the Attachments window.
Help	Display online help.

Forwarding Messages

Messages can be forwarded to other users. Select the message and click the **Forward** button on the **Home** tab of the toolbar, or right-click on the message and select **Forward Message** from the popup menu.

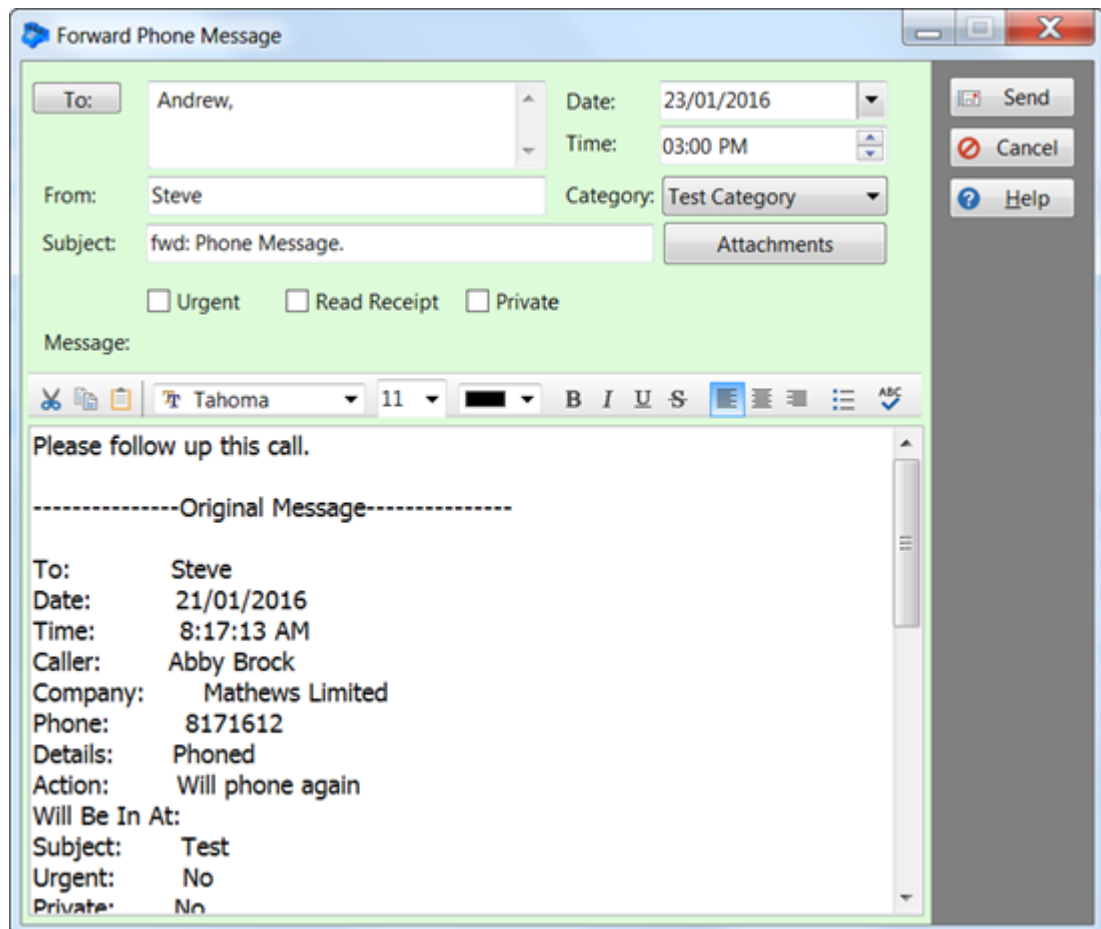

Replying to Messages

You can reply to a message that you have received from another user. Select the message and click the **Reply** button on the **Home** tab of the toolbar, or right-click on the message and select **Reply to Message** from the popup menu.

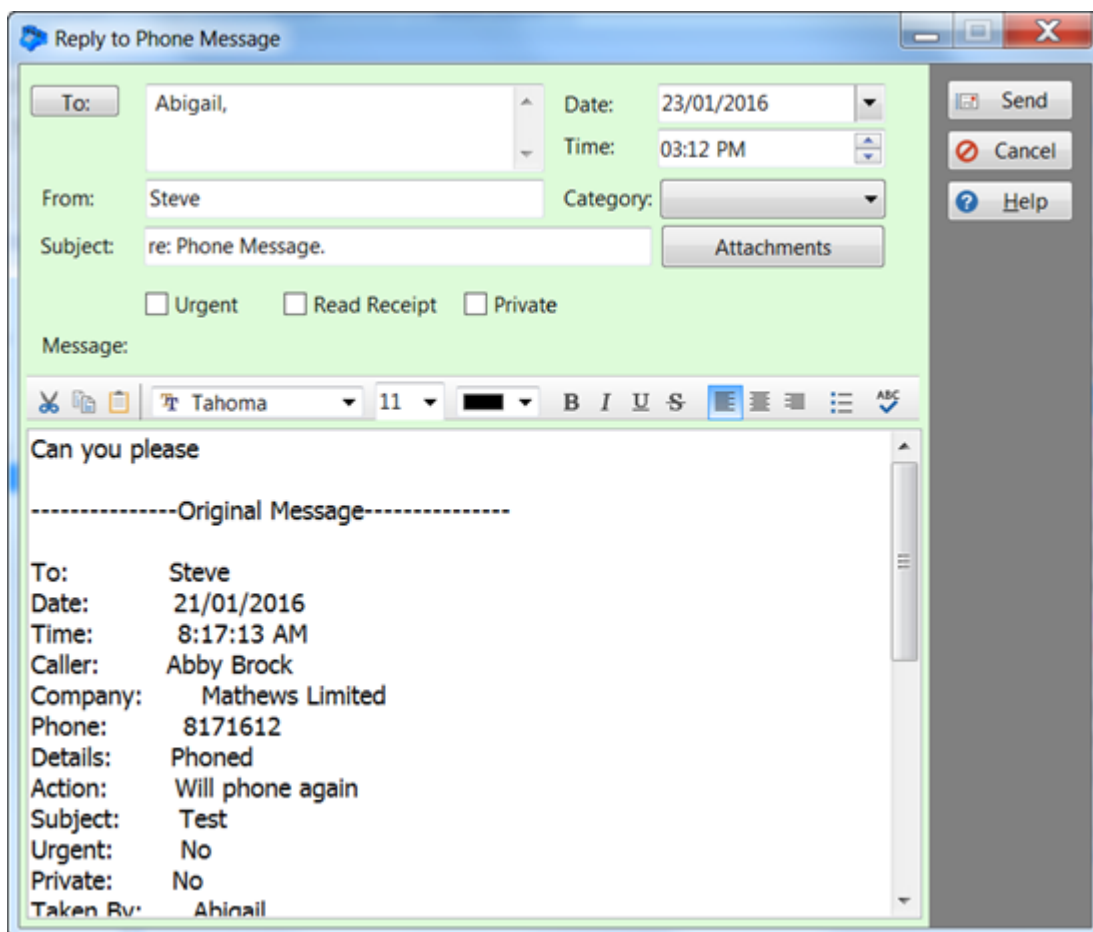

Resending Messages

Messages that you have sent previously can be resent to the same recipients. Select the message in your Sent folder and click the **Resend** button on the **Home** tab of the toolbar, or right-click on the message and select **Resend Message** from the popup menu.

Moving Messages to Another User's Inbox

If you receive a message that should be assigned to someone else, you can move the message to their Inbox. You will need to have access to the other user's Inbox before doing this.

Inbox for Steve			Search			
				ID	Date	Caller
Abigail	10	6				
Andrew	32	17				
Jen	1	1				
Jasper	1	1				
John	1	1				
Steve	40	22				
				507	01/04/2016 2:49 pm	Abby Br
				505	25/03/2016 7:27 pm	Sabrina
				503	25/03/2016 7:19 pm	Walter
				501	24/03/2016 2:36 pm	Mabel C
				499	24/03/2016 1:53 pm	Sabrina
				489	23/03/2016 6:42 am	Heather
				487	23/03/2016 6:39 am	Gena Gc
				483	18/03/2016 9:57 am	Lacey B
				481	18/03/2016 8:18 am	Barbara

Select the messages you want to reassign, and while holding down the **<alt>** key and **left mouse button**, move the cursor to the user you want to reassign the messages to, then release the mouse button. The messages will immediately be moved from your Inbox to their Inbox.

Message History

When you view a phone, text or outgoing message, at the bottom of the window is a **History** tab.

Click the History tab, and then click the Refresh button to load the history for the message.

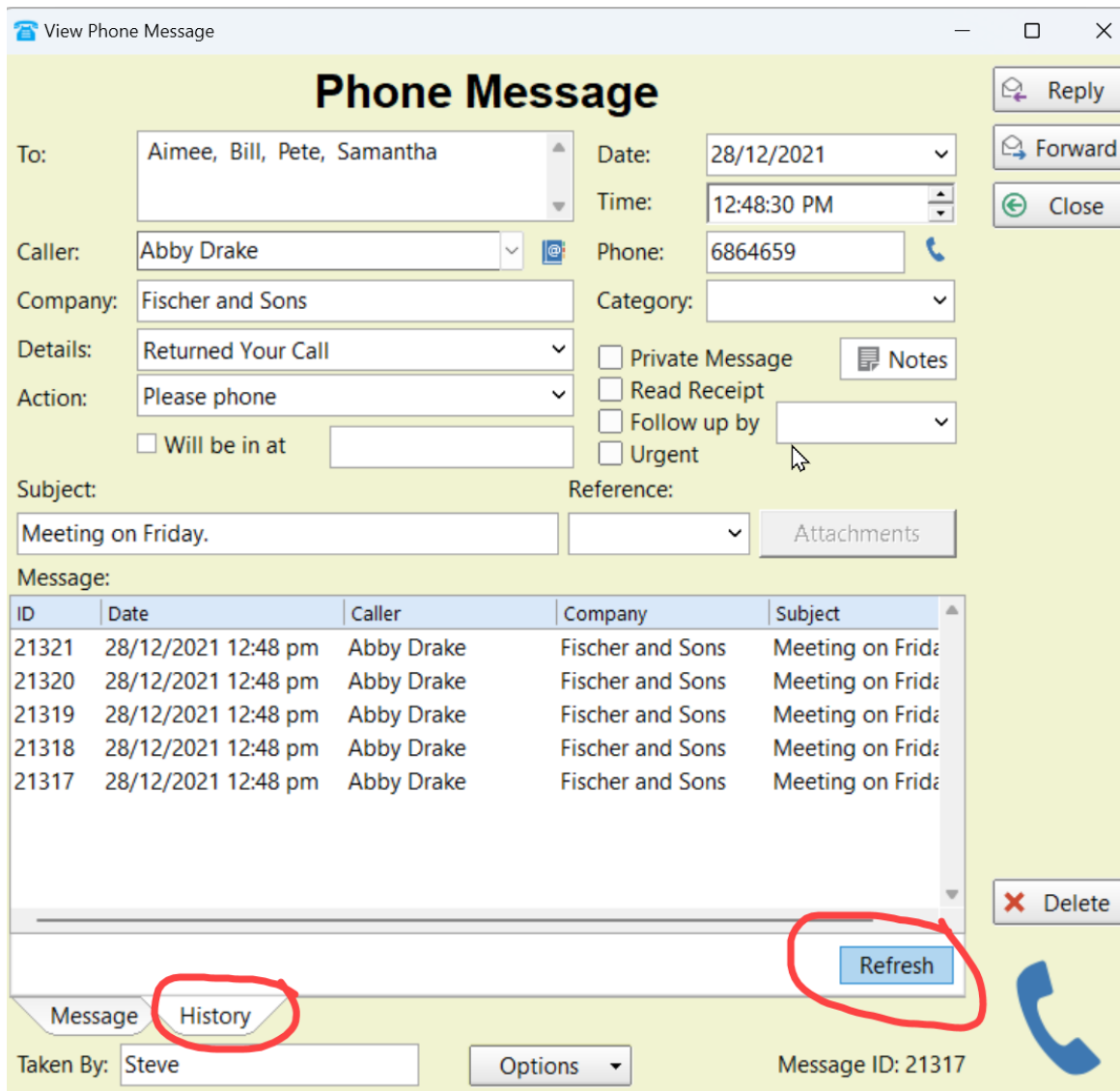

In this example, there are 5 messages (including the current one). You can view any of these messages by double-clicking on them.

Editing Received or Sent Messages

If your PhonePad administrator has enabled message editing for messages that have been sent or received, then you will be able to change some of the details of messages.

When you view a message, if it can be edited "EDIT MODE" will be displayed in the message title bar.

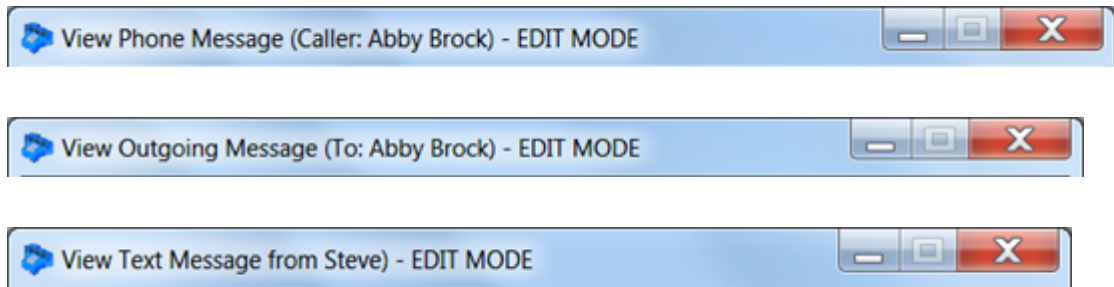

If you make any changes to a message you will be prompted to save the changes when you close it.

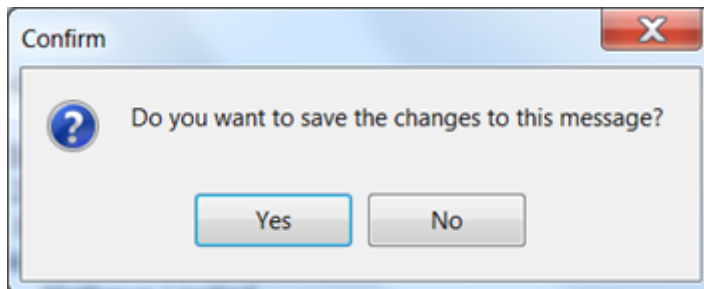

Deleting Messages

You can delete messages from any of your folders by selecting the message and clicking the **Delete** button on the **Home** tab of the toolbar, or by selecting **Delete Message** from the **File** menu, or by pressing the **<delete>** or **** key on your keyboard.

You will be asked to confirm the deletion.

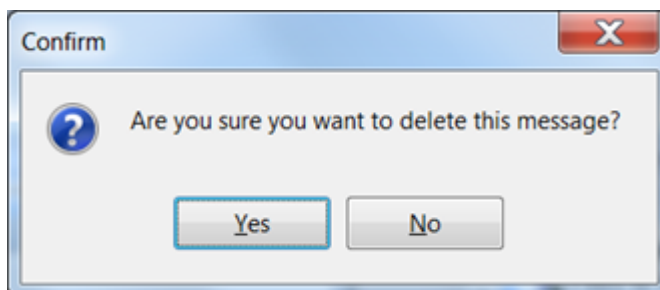

Deleted messages go to your Deleted folder. If you need to undelete a message from the **Deleted** folder, select the message and then click the **Undelete Messages**

button on the **Folders** tab of the toolbar, or right-click on the message and select **Undelete Messages**.

You will be asked to confirm the undeletion.

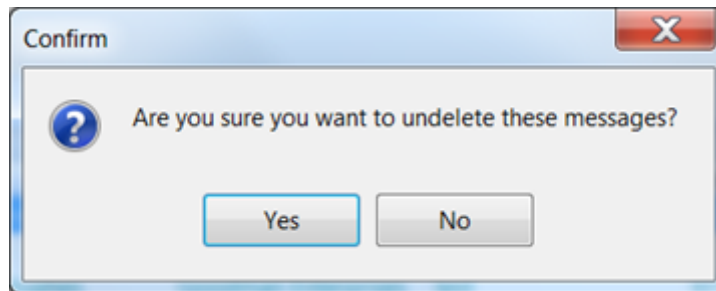

 Messages are automatically deleted from the **Deleted** folder after they have been there for 14 days.

CallFlow

CallFlow provides a way to view all interactions with a caller in one place. It shows a complete history of all incoming and outgoing calls, and follow up notes.

CallFlow

CallFlow shows all Incoming messages, Outgoing messages, and Follow Up Notes for a caller in chronological order. This allows you to view the sequence of all interaction with the caller.

Caller: Abby Brock Company: Mathews Limited

Search

ID	Date	To	Subject	Phone	Sender
292	22/01/2016 3:39 PM	Michael	RE: System Issues.	8171612	Steve
290	21/01/2016 3:59 PM	Michael	RE: System Issues.	8171612	Steve
75	21/01/2016 9:10 AM	Abby Brock	COMPLETED		Steve
286	21/01/2016 8:17 AM	Steve	Test	8171612	Steve
284	21/01/2016 8:11 AM	Andrew	Please send conference details.	8171612	Steve
276	20/01/2016 11:18 AM	Abby Brock	RE: Documents.	8171612	Steve
275	20/01/2016 11:17 AM	Steve	Golf on Thursday?	8171612	Steve
269	8/12/2015 10:20 AM	Steve	Tuesday Meeting.	8171612	Steve

Outgoing Call

Message ID: 276 To: Abby Brock Subject: RE: Documents.
 Message Date: 20/01/2016 11:18 AM Phone: 8171612 Sender: Steve
 Message: Called Abby. She said the documents will be returned on Friday by courier.

View Print List Close

View	Click this button to view an incoming or outgoing message.
Print List	Print a list of all messages.
Close	Close this window.

Printing Messages

There are various print options in PhonePad.

Print Messages

To print one or more messages, select the messages from the message list and then click the **Print** button on the **Home** tab of the toolbar, or select **Print** from the **File** menu.



You will be presented with a number of choices (refer to Printing Options for an explanation of each report).

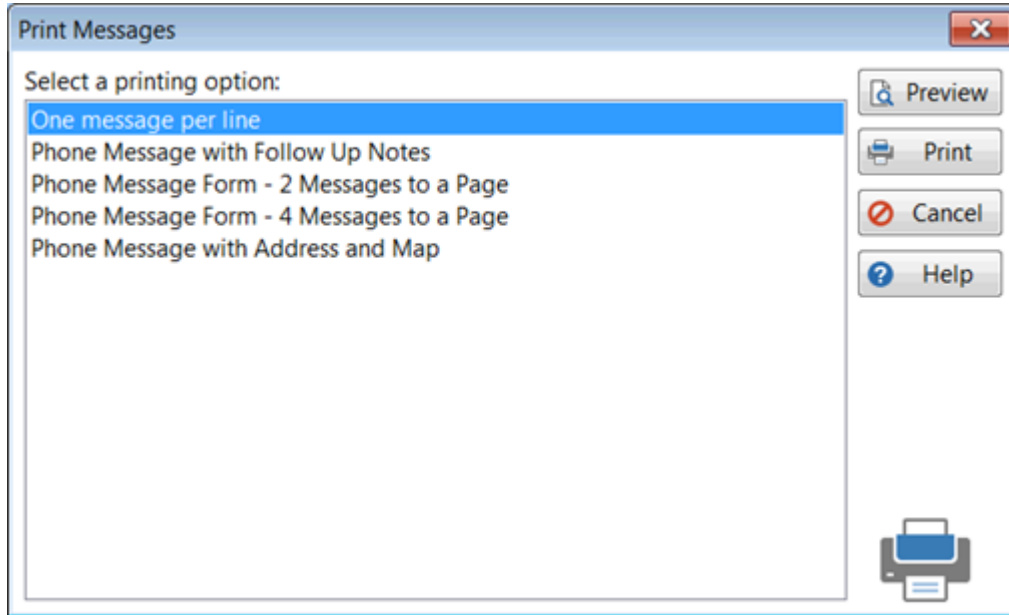

Select a printing option then click **Preview**. The Preview window will be displayed.

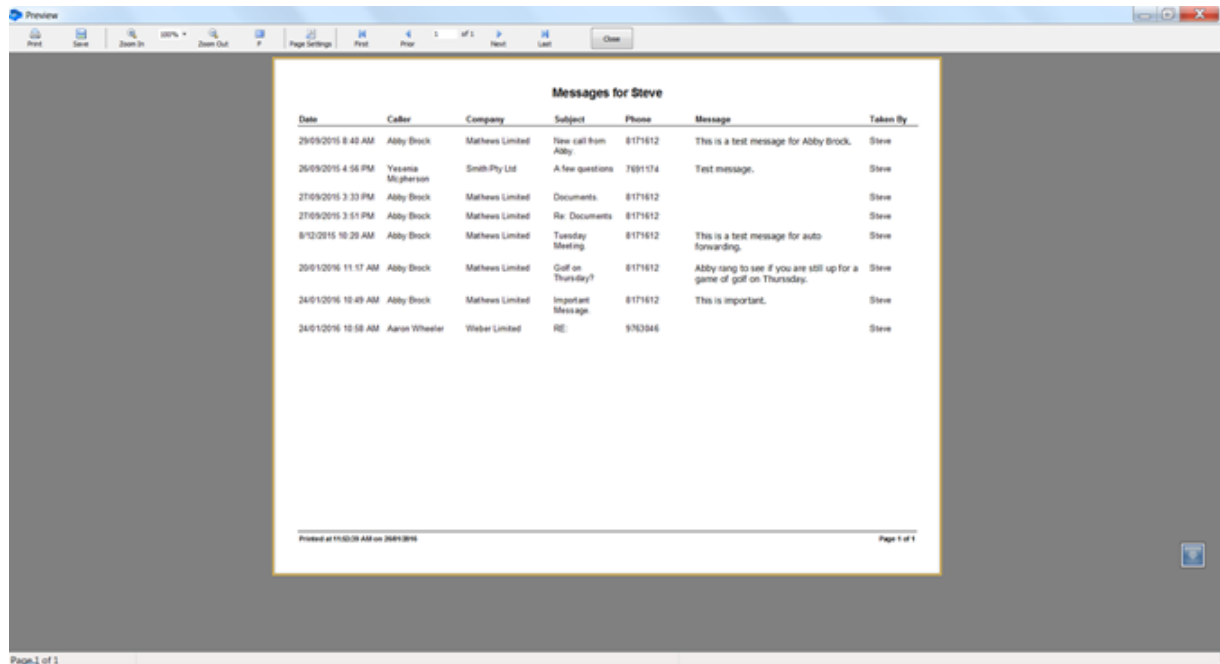

The Preview toolbar features a number of options:



1	Print	Print the report.
2	Save	Export the report to a number of formats including PDF.
3	Zoom In	Zoom in to the page.
4	Zoom Percentage	Select or enter a zoom percentage.
5	Zoom Out	Zoom out from the page.
6	Fullscreen	Display the report in Fullscreen mode.
7	Page Settings	Change the page settings.
8	First	Jump to the first page of the report.
9	Prior	Move to the previous page.
10	Page Number	Shows the current page number. You can directly enter a page number here.
11	Next	Move to the next page.
12	Last	Jump to the last page of the report.
13	Close	Close the report.

Printing Options

These are the currently available printing options for the **Print** option.

One message per line	Messages are printed across the page with one message per line.
Phone Message with Follow Up Notes	Each message is printed one to a page with Follow Up Notes included.
Phone Message Form - 2 Messages to a Page	Messages are printed in the message form format, which looks like the paper-based message pads. Two to a page are printed.
Phone Message Form - 4 Messages to a Page	Messages are printed in the message form format, which looks like the paper-based message pads. Four to a page are printed. Depending on the message content this may not be the best way to print them. If the message text is large then it will not all fit on the page.

Example Printouts

Messages for Steve						
Date	Caller	Company	Subject	Phone	Message	Taken By
8/12/2015 10:20 AM	Abby Brock	Mathews Limited	Tuesday Meeting.	8171612	This is a test message for auto forwarding.	Steve
20/01/2016 11:17 AM	Abby Brock	Mathews Limited	Golf on Thursday?	8171612	Abby rang to see if you are still up for a game of golf on Thursday.	Steve
20/01/2016 8:26 PM	Abby Brock		Urgent Matter.	8894563	Please call.	Steve
21/01/2016 8:17 AM	Abby Brock	Mathews Limited	Test	8171612	Test	Steve

Printed at 10:56:04 AM on 26/01/2016 Page 1 of 1

Image: One message per line

While You Were Out

Message ID: 289
To: Steve
Date: 8/12/2015 10:20 AM
Caller: Abby Block
Company: Matthews Limited
Phone: 8171812
Details: Phoned
Action: No Action Required
Subject: Tuesday Meeting
Message:
This is a test message for auto forwarding.

Urgent
 Private
 Receipt
Will be in at:

Taken By: Steve

Follow Up Notes:

Printed at 10:58:33 AM on 20/01/2016PhonePad 5

Image: Print Message with Follow Up Notes

While You Were Out	
To: Steve	Date: 8/12/2015 10:20 AM
Caller: Abby Brock	Time: 8/12/2015 10:20 AM
Company: Mathews Limited	Phone: 8171612
<input checked="" type="checkbox"/> Phoned	<input checked="" type="checkbox"/> No action required <input type="checkbox"/> Wants to see you
<input type="checkbox"/> Returned your call	<input type="checkbox"/> Please phone <input type="checkbox"/> Will be in at:
<input type="checkbox"/> Came to see you	<input type="checkbox"/> Will phone again
<input type="checkbox"/> Urgent	<input type="checkbox"/> Will drop by again <input type="checkbox"/> Private
Subject: Tuesday Meeting.	
Message: This is a test message for auto forwarding.	
Taken By: Steve _____ Message ID: 269	

While You Were Out	
To: steve	Date: 20/01/2016 11:17 AM
Caller: Abby Brock	Time: 20/01/2016 11:17 AM
Company: Mathews Limited	Phone: 8171612
<input type="checkbox"/> Phoned	<input type="checkbox"/> No action required <input type="checkbox"/> Wants to see you
<input checked="" type="checkbox"/> Returned your call	<input checked="" type="checkbox"/> Please phone <input type="checkbox"/> Will be in at:
<input type="checkbox"/> Came to see you	<input type="checkbox"/> Will phone again
<input type="checkbox"/> Urgent	<input type="checkbox"/> Will drop by again <input type="checkbox"/> Private
Subject: Golf on Thursday?	
Message: Abby rang to see if you are still up for a game of golf on Thurssday.	
Taken By: Steve _____ Message ID: 275	

Printed at 11:02:40 AM on 26/01/2016 PhonePad Version 5.0.0

Image: Phone Message Form - 2 Messages per Page

While You Were Out	
To: Steve	Date: 8/12/2015 10:20 AM
Caller: Abby Brook	Time: 8/12/2015 10:20 AM
Company: Mathews Limited	Phone: 017612
<input checked="" type="checkbox"/> Phoned	<input checked="" type="checkbox"/> No action required <input type="checkbox"/> Wants to see you
<input type="checkbox"/> Returned your call	<input type="checkbox"/> Please phone <input type="checkbox"/> Will Be In At:
<input type="checkbox"/> Came to see you	<input type="checkbox"/> Will phone again
<input type="checkbox"/> Urgent	<input type="checkbox"/> Will drop by again <input type="checkbox"/> Private
Subject: Tuesday Meeting.	
Message:	
This is a test message for auto forwarding.	
Taken By: Steve	
Message ID: 269	
This message is marked for Follow Up.	
While You Were Out	
To: Steve	Date: 20/01/2016 11:17 AM
Caller: Abby Brook	Time: 20/01/2016 11:17 AM
Company: Mathews Limited	Phone: 017612
<input type="checkbox"/> Phoned	<input type="checkbox"/> No action required <input type="checkbox"/> Wants to see you
<input checked="" type="checkbox"/> Returned your call	<input checked="" type="checkbox"/> Please phone <input type="checkbox"/> Will Be In At:
<input type="checkbox"/> Came to see you	<input type="checkbox"/> Will phone again
<input type="checkbox"/> Urgent	<input type="checkbox"/> Will drop by again <input type="checkbox"/> Private
Subject: Golf on Thursday?	
Message:	
Abby rang to see if you are still up for a game of golf on Thursday.	
Taken By: Steve	
Message ID: 275	
While You Were Out	
To: Steve	Date: 20/01/2016 02:28 PM
Caller: Abby Brook	Time: 20/01/2016 02:28 PM
Company:	Phone: 0294562
<input checked="" type="checkbox"/> Phoned	<input checked="" type="checkbox"/> No action required <input type="checkbox"/> Wants to see you
<input type="checkbox"/> Returned your call	<input type="checkbox"/> Please phone <input type="checkbox"/> Will Be In At:
<input type="checkbox"/> Came to see you	<input type="checkbox"/> Will phone again
<input type="checkbox"/> Urgent	<input type="checkbox"/> Will drop by again <input type="checkbox"/> Private
Subject: Urgent Matter.	
Message:	
Please call.	
Taken By: Steve	
Message ID: 280	
While You Were Out	
To: Steve	Date: 21/01/2016 0:17 AM
Caller: Abby Brook	Time: 21/01/2016 0:17 AM
Company: Mathews Limited	Phone: 017612
<input checked="" type="checkbox"/> Phoned	<input type="checkbox"/> No action required <input type="checkbox"/> Wants to see you
<input type="checkbox"/> Returned your call	<input type="checkbox"/> Please phone <input type="checkbox"/> Will Be In At:
<input type="checkbox"/> Came to see you	<input checked="" type="checkbox"/> Will phone again
<input type="checkbox"/> Urgent	<input type="checkbox"/> Will drop by again <input type="checkbox"/> Private
Subject: Test	
Message:	
Test	
Taken By: Steve	
Message ID: 286	

Printed at 11:03:43 AM on 20/01/2016 PhonePad Version 5.0.0

Image: Phone Message Form - 4 Messages per Page

While You Were Out

Message ID: 588
To: Andrew
Date: 20/05/2016 10:27 PM
Caller: Jennifer Andreason
Company: Wilson Group
Phone: 555 6666
Details: Phoned
Action: No Action Required
Subject: Quotation.

- Urgent
 - Private
 - Receipt
- Will be in at:

Message:

Lorem ipsum dolor sit amet, consectetur adipiscing elit. Maecenas at leo eget nisi porta viverra. Ut laoreet, dui at tempus vestibulum, eros leo egetas neque, id adipiscing odio eros et lectus. Vivamus pretium lorem sit amet nulla. Praesent nec dolor at augue ultrices blandit. Quisque aliquet ultrices mi.

Address: 54 Key West Street, Nassau , The Bahamas

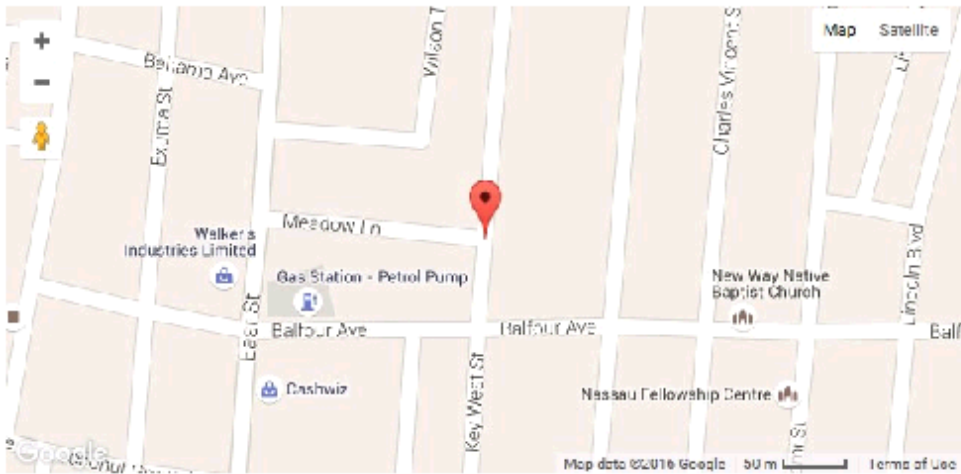

Image: Phone Message with Address and Map

Quick Print

Quick Print prints selected messages in a different format than the other reports. To use Quick Print, click on the **Quick Print** button on the **Home** tab of the toolbar, or select **Quick Print** from the **File** menu.



The Quick Print preview window will be displayed.

XYZ Corporation

Quick Print Report of Inbox Messages

Msg ID:	207	Date:	29/09/2015 8:40 AM
To:	Steve	Company:	Mathews Limited
Caller:	Abby Brock	Action:	No Action Required
Details:	Phoned	Urgent:	No
Subject:	New call from Abby.		
Message:	This is a test message for Abby Brock.		

Msg ID:	269	Date:	8/12/2015 10:20 AM
To:	Steve	Company:	Mathews Limited
Caller:	Abby Brock	Action:	No Action Required
Details:	Phoned	Urgent:	No
Subject:	Tuesday Meeting		
Message:	This is a test message for auto forwarding.		

Msg ID:	275	Date:	20/01/2016 11:17 AM
To:	steve	Company:	Mathews Limited
Caller:	Abby Brock	Action:	Please Phone
Details:	Returned Your Call	Urgent:	No
Subject:	Golf on Thursday?		
Message:	Abby rang to see if you are still up for a game of golf on Thursday.		

<small>Printed on 26/01/2016 at 12:16:48 PM</small>		<small>PhonePad 5</small>	
<small>Page 1 of 2 Pages</small>			

Print Message List

The Print Message List option allows you to print a list of all messages in the current folder. To print a list of messages, click on the **Print Message List** button on the **Home** tab of the toolbar, or select **Print Message List** from the **File** menu.



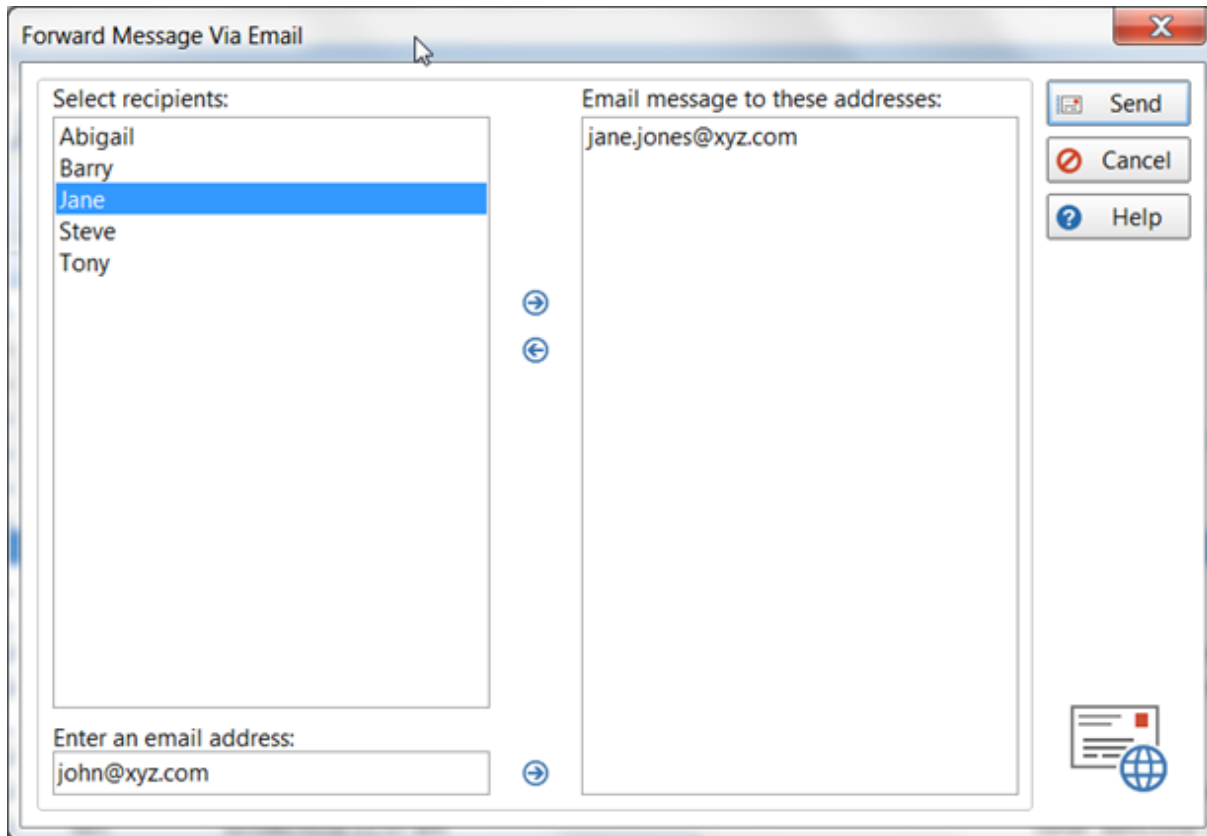

The **Select Recipients** list will only show PhonePad users that have an email address.

To send an email to one or more of these users, you need to add them to the **Email messages to these addresses** list. You can do this by double-clicking on their name, or by selecting them and clicking the right-arrow button, or by dragging and dropping.

To remove someone from the list, double-click on their name, or by select them and click the right-arrow button, or by drag and drop them back to the list on the left.

You can also enter a person's email address under **Enter an email address** and add them to the list by clicking the right-arrow button.s

Email Message Settings

If you have administrator access, a **Settings** button will also be displayed on this screen.

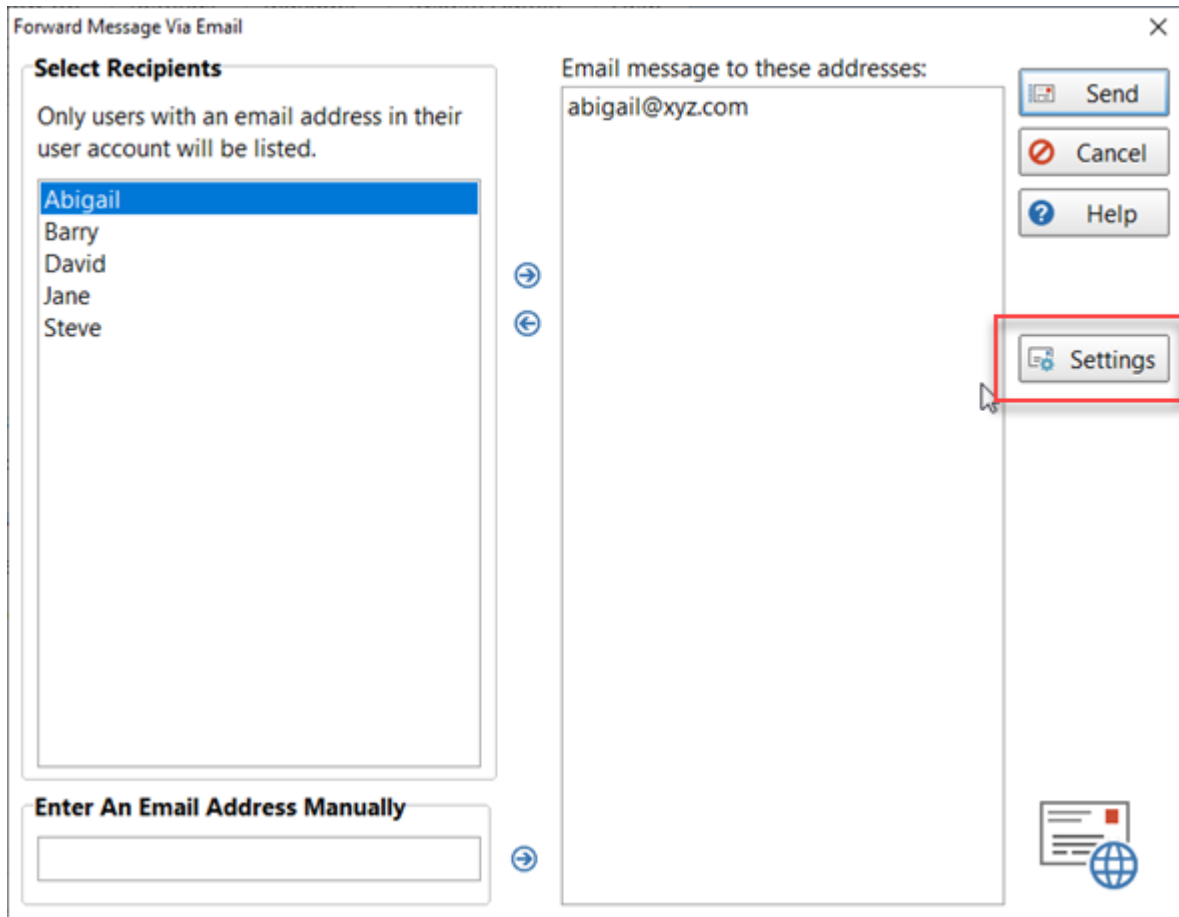

Click the **Settings** button to access the settings used by the **Email Message** feature to send emails.

When the **Email Message Settings** screen appears, you have the option of using the settings set up under **Communication Settings** (the default), or to set up specific email settings for the **Email Message** feature (**Use Mail Server**).

If you want the Email Message feature to use separate settings then select **Use Mail Server**.

Enter the address of your **SMTP Server** and the **SMTP Port** number.

To make things easier, you can use the drop-down list to select an email service provider, then click the **Apply Preset** button (if your provider is listed). This will

change the settings to suit the provider you are using. All you need to do then is enter your account details (eg. Account Username/Email Address and Password).

These are settings we have tested, or that have been tested by customers, and are known to work. More presets will be added over time. If you are using an email provider not listed and you have settings that have been proven to work, please let us know and we'll add them.

Email Message Settings

Configure how the **Email Message** feature sends emails. You can use the same settings as the **Automatic Message Forwarding** feature under **Communication Settings** or you can configure a separate mail system.

Use Communication Settings
 Use Mail Server

SMTP Server Mail User Account Authentication

SMTP Server:

SMTP Port:

Use an email service preset:

Select the **Mail User Account** tab and enter in the details.

Finally, select the **Authentication** tab and select the appropriate authentication settings for your mail server.

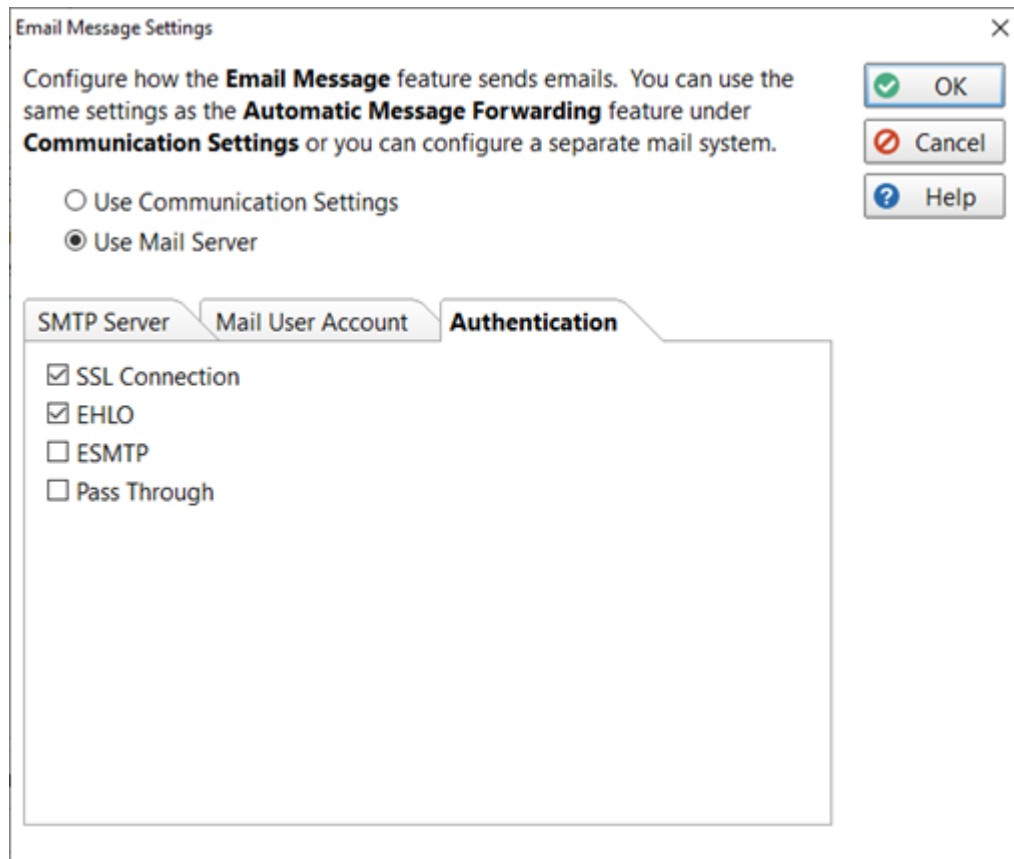

Click **OK** to save the changes.

Smart Assistance

What is Smart Assistance?

Smart Assistance is PhonePad's built-in assistant that analyzes the content of a message as you type and automatically suggests useful actions.

Think of it as a sharp-eyed receptionist who never blinks — spotting dates, names, and intent before you even finish typing.

What does it do?

Smart Suggest can automatically detect and suggest:

? Follow-up dates

Follow-up required flags

? Contacts or recipients

? Phone numbers entered in the message

? Context-based suggestions (based on message content)

How it works

You can either activate it by clicking the **Suggest** button, or have it automatically make suggestions by enabling **Auto Suggest** under your Preferences.

They say that a picture is worth 1000 words, so let's have a quick look at how it works.

In this example I have typed in just the message text.

Phone Message

To: [Empty]

Caller: [Enter or select caller]

Company: [Enter or select an entry]

Details: [Empty]

Action: [Empty]

Will be in at: [Empty]

Custom 1: [Empty]

Custom 2: [Empty]

Email: [Empty] D.O.B: [Empty]

Subject: [Enter a subject for this message.]

Reference: [Empty]

Message:

Abby Brock returned your call. Please call her back.

Taken By: Steve

Options [Dropdown]

Send, Cancel, Help, Suggest

After clicking the **Suggest** button, **Smart Suggest** extracts the details and automatically fills in the appropriate fields.

Phone Message

To: [Empty]

Caller: Abby Brock

Company: Brock Co

Details: Phoned

Action: Please phone

Will be in at: [Empty]

Custom 1: [Empty]

Custom 2: [Empty]

Email: [Empty] D.O.B: [Empty]

Subject: Abby Brock - Please phone

Reference: [Empty]

Message:
Abby Brock returned your call. Please call her back.

Taken By: Steve

Buttons: Send, Cancel, Help, Suggest, Options, Show Hints

Fields: Date: 20/04/2026, Time: 1:39:50 PM, Phone: 777 555 4444, Category: General, Private Message, Read Receipt, Follow up by, Urgent, Attachments

Please note: Smart Suggest won't overwrite fields that aren't empty.

Chapter

4

Short Messages

Short Messages

Short Messages are text messages sent directly to users or contacts using either Pushover or SMS (Short Message Service). They are unrelated to phone messages you log.

The **Pushover** option is intended for sending messages to staff as the recipient of the message must have the Pushover application installed on their mobile device, and they need to be connected under the same Pushover account.

The **SMS** option enables you to send messages to clients as it uses the cell network.

To access the **Short Messages** options, click on the **Short Messages** button on the toolbar, or select **Short Messages** from the **Tools** menu, then select **Pushover Messages** or **SMS Messages**.

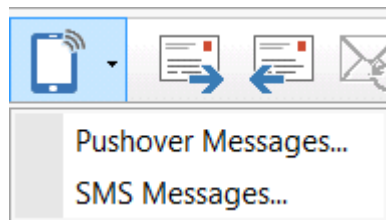

If the options aren't enabled then you will need to get your PhonePad Administrator to give you access.

Pushover Messages

The Pushover Messages window has two tabs: one for scheduled messages and another tab shows all messages that have been sent for the logged in user.

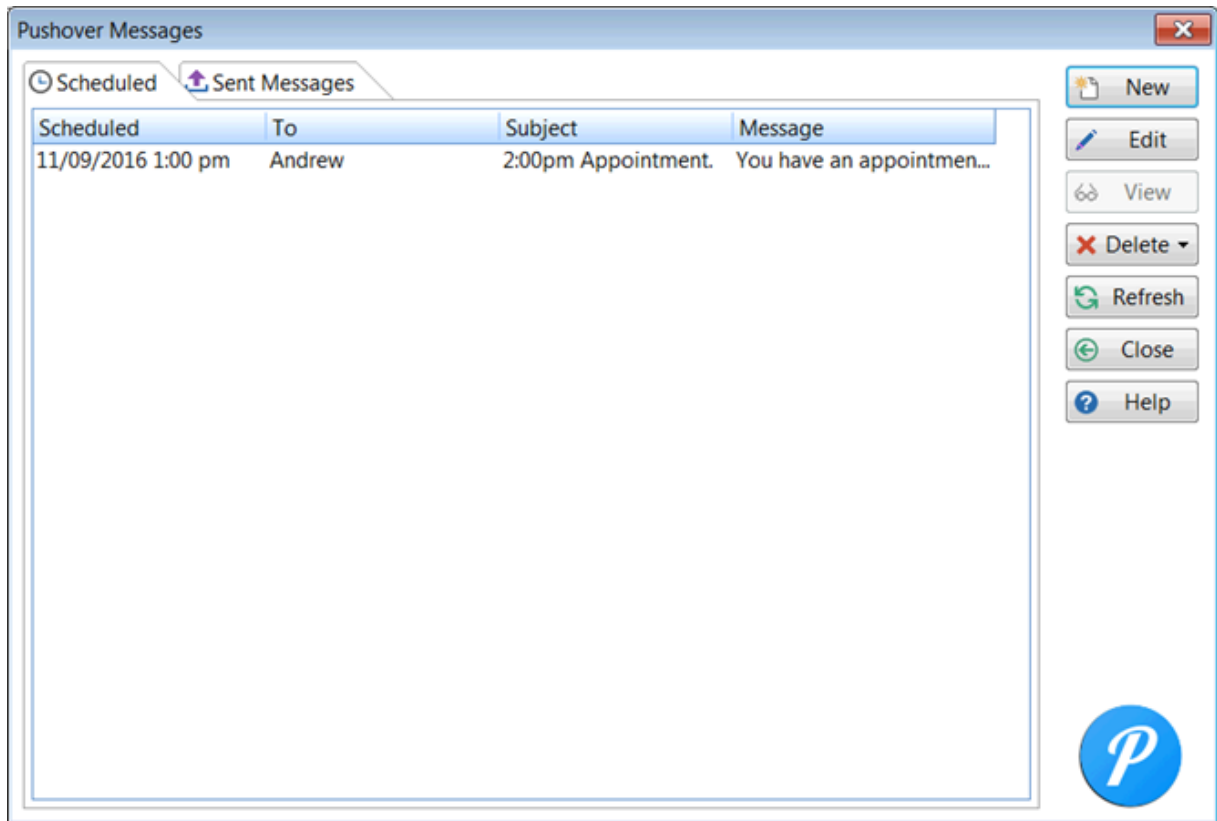

New	Click to create a new scheduled or unscheduled message.
Edit	Click to edit a scheduled message.
View	Click to view a sent message.
Delete	Click to display a drop-down menu where you can delete a selected message or all messages.
Refresh	Refresh the list of messages.
Close	Click to close this window.
Help	Display help.

Sending a Pushover Message

To send a Pushover message:

1. Click the **New** button.

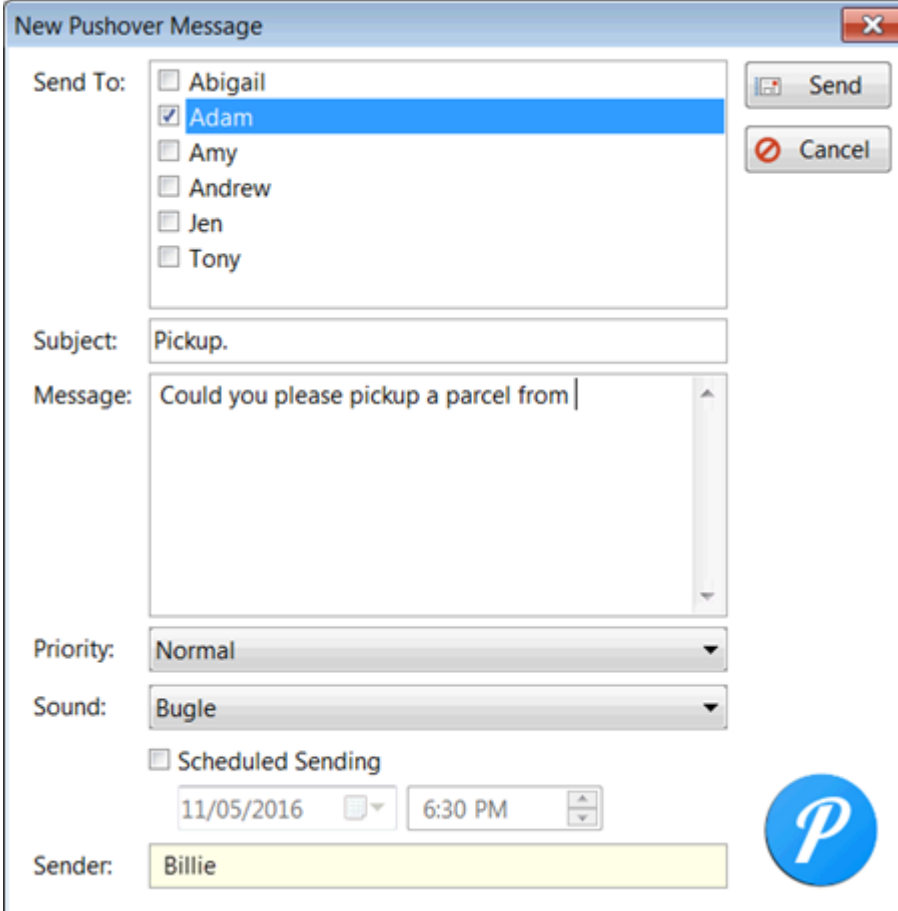

The screenshot shows a "New Pushover Message" dialog box. It features a "Send To:" list with checkboxes for Abigail, Adam (checked), Amy, Andrew, Jen, and Tony. To the right of the list are "Send" and "Cancel" buttons. Below the list is a "Subject:" field containing "Pickup." and a "Message:" text area containing "Could you please pickup a parcel from |". At the bottom, there are dropdown menus for "Priority:" (Normal) and "Sound:" (Bugle), a "Scheduled Sending" checkbox, a date/time selector (11/05/2016 6:30 PM), and a "Sender:" field (Billie). A blue circular logo with a white "P" is in the bottom right corner.

2. Select the users you want to send the message to (messages can be sent to multiple users.).
3. Enter a **Subject** (optional).
4. Enter your **Message**.
5. You can select the **Priority** of the message. The default is **Normal**.
6. Although users can set the default notification sound on their mobile devices, you can override the sound by selecting a **Sound** from the drop-down menu.

7. If you don't want to send the message straight away you can schedule it for a later date and time. Just check the **Scheduled Sending** check box, and then enter a date and time.
8. Click **Send** to send the message. If this is a scheduled message then it will appear in the list of scheduled messages.

SMS Messages

When you select **SMS Messages**, the following window will be displayed.

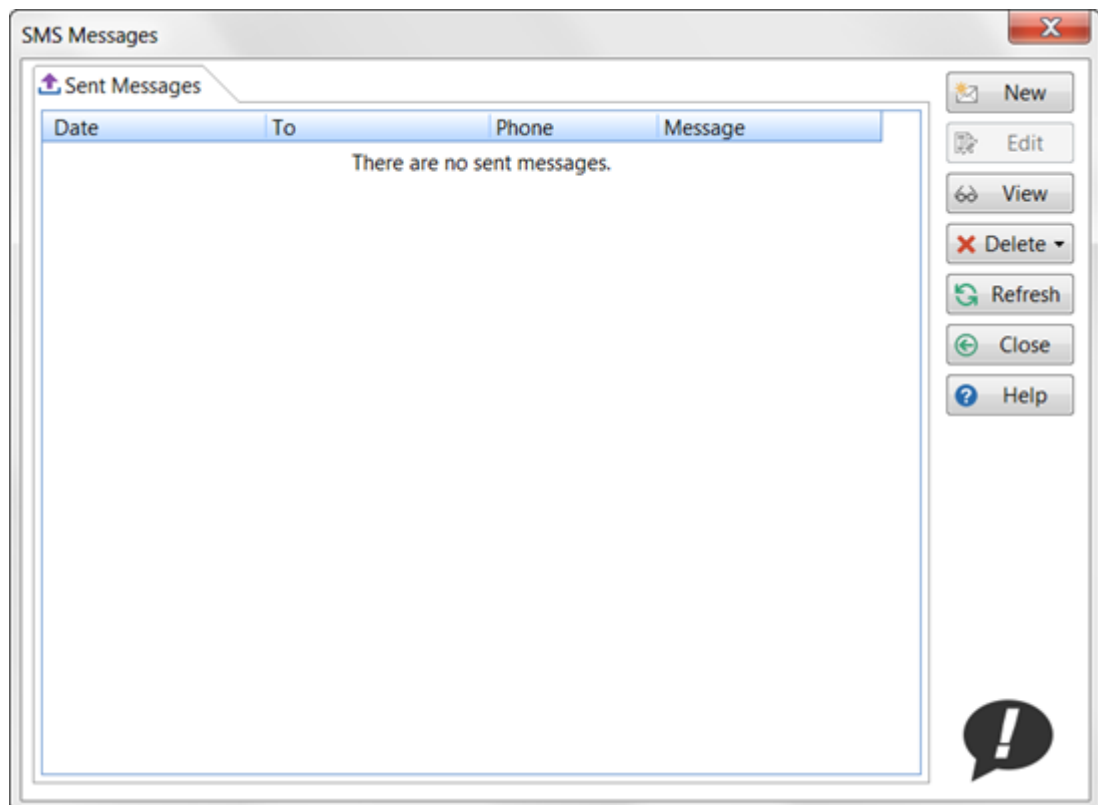

New	Click to create a new scheduled or unscheduled message.
Edit	Will be used for editing scheduled messages when this feature becomes available.
View	Click to view a sent message.

Delete	Click to display a drop-down menu where you can delete a selected message, or all messages.
Refresh	Refresh the list of messages.
Close	Click to close this window.
Help	Display help.

Sending an SMS Message

To send an SMS message:

1. Click the **New** button.
2. The **New SMS Message** window will be displayed
3. Click on the small icon to the immediate right of the **Send To** field.

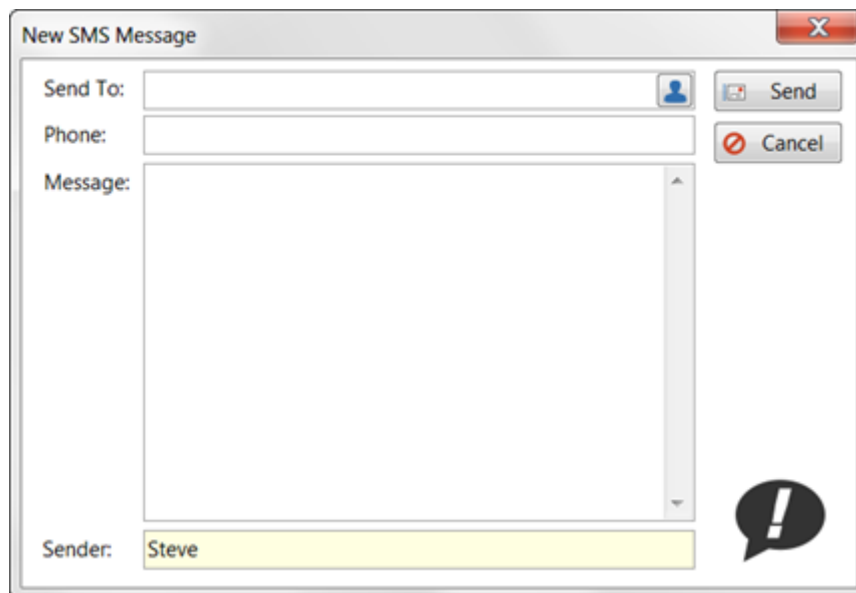

4. The **Caller Lookup** window will open. As you enter text into the **Search** field it will perform an incremental search of all callers in your Address Book.

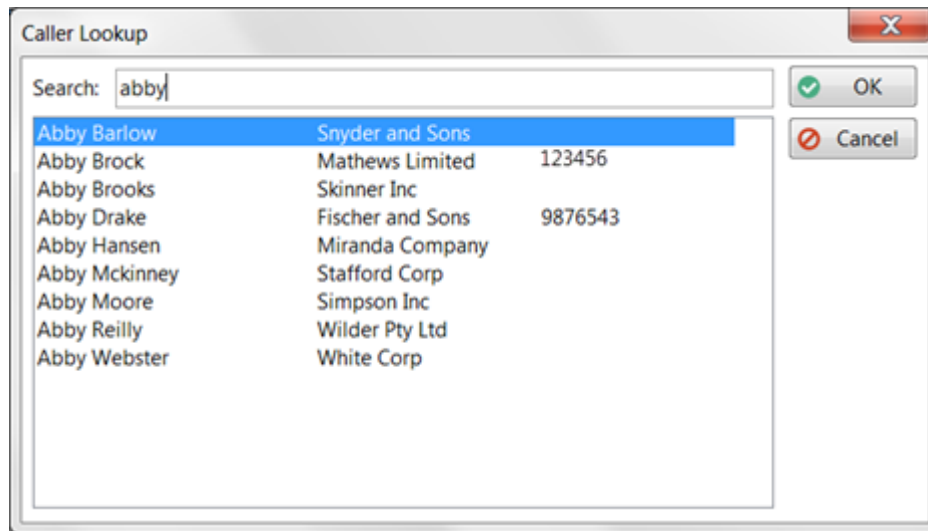

5. When you have found the person you were looking for, select them and click **OK**.
6. You will be taken back to the **New SMS Message** window. Enter the text of your message and then click the **Send** button.

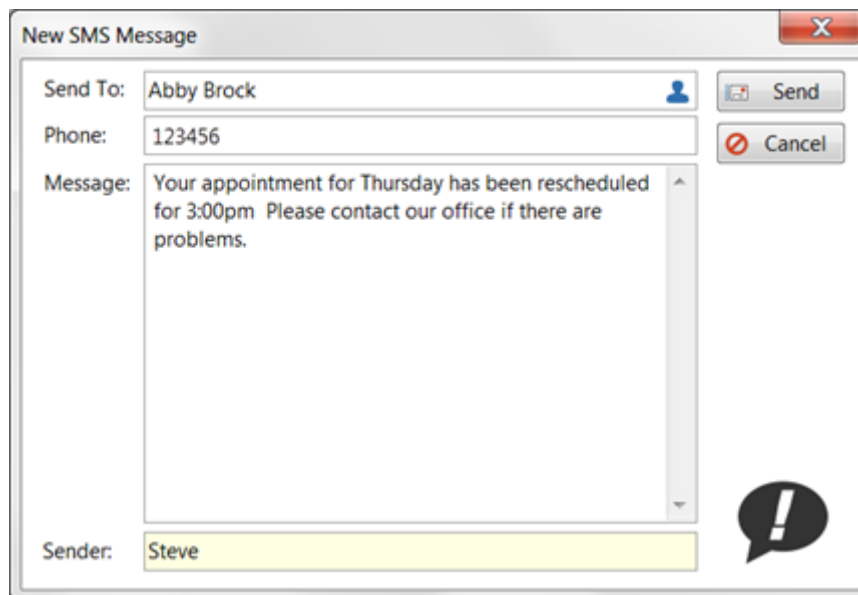

7. The SMS message will be sent right away and the message you sent will be displayed in the list of sent messages.

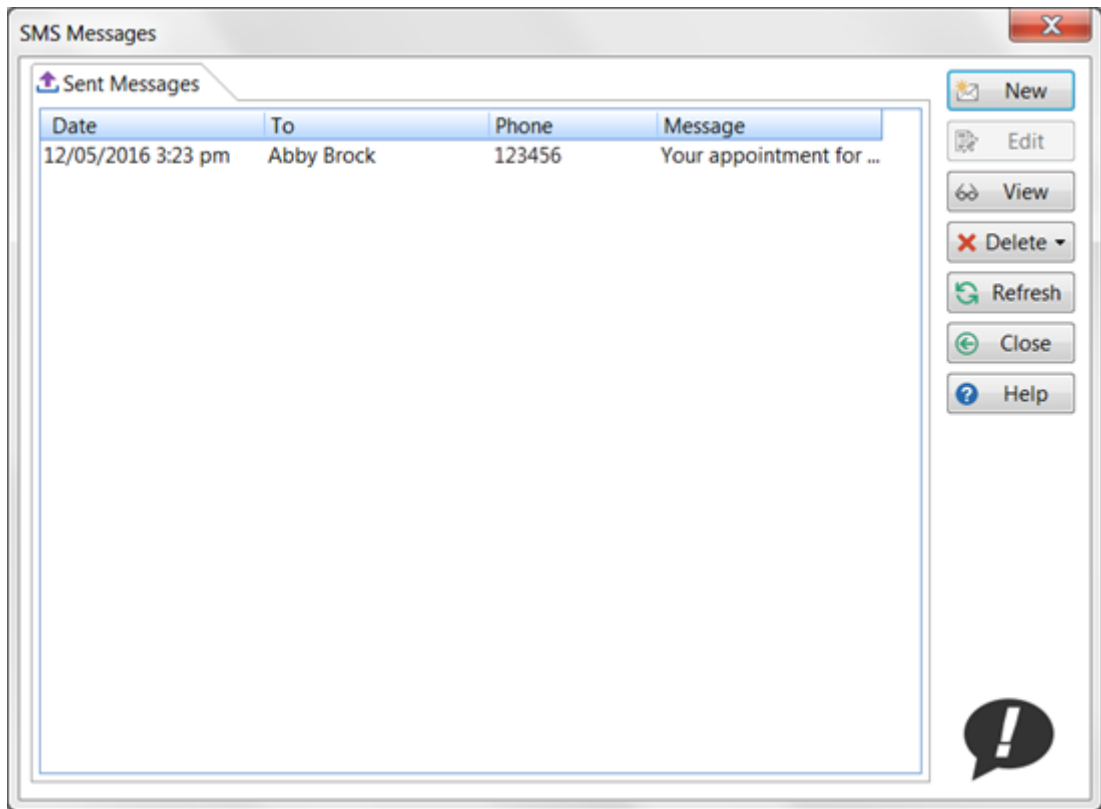

Chapter

5

Folders

Folders

Your messages in PhonePad 5 are organized into a number of folders: **Inbox**, **Outgoing**, **Sent** and **Deleted**. You can also create your own **Personal** and **Public** folders, and your administrator can set up **Group** folders that you can be given access to.

All of these are displayed in the Folder Tree.

Inbox

The Inbox is a special folder. This is where all of your phone and text messages will arrive when someone sends them to you.

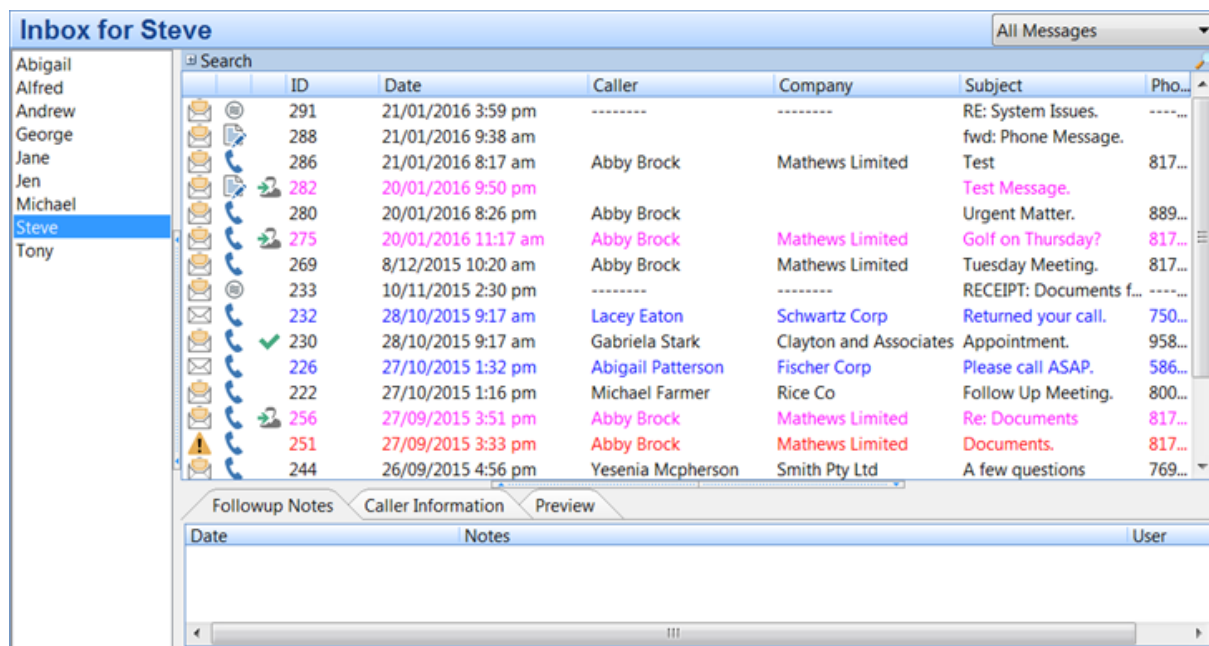

The User List

If you have access to other users' Inboxes you will also see a list of those users to the left of your Inbox. You can select a user from the list to access their Inbox. The Inbox title bar will display the name of the user whose Inbox you are viewing.

Message Counts

The User list can be configured to show message counts for each user. The first column is the number of unread messages for the user, and the second column shows the number of uncompleted follow ups.

Inbox for Steve		
Abigail	10	6
Andrew	32	17
George	2	1
Jen	1	1
Barry	1	0
Amy	1	0
Catherine	0	0
Bill	0	0
Rachel	0	0
Steve	40	22

To configure this, select **Preferences** from the **View** menu, then select **Messages - 1**.

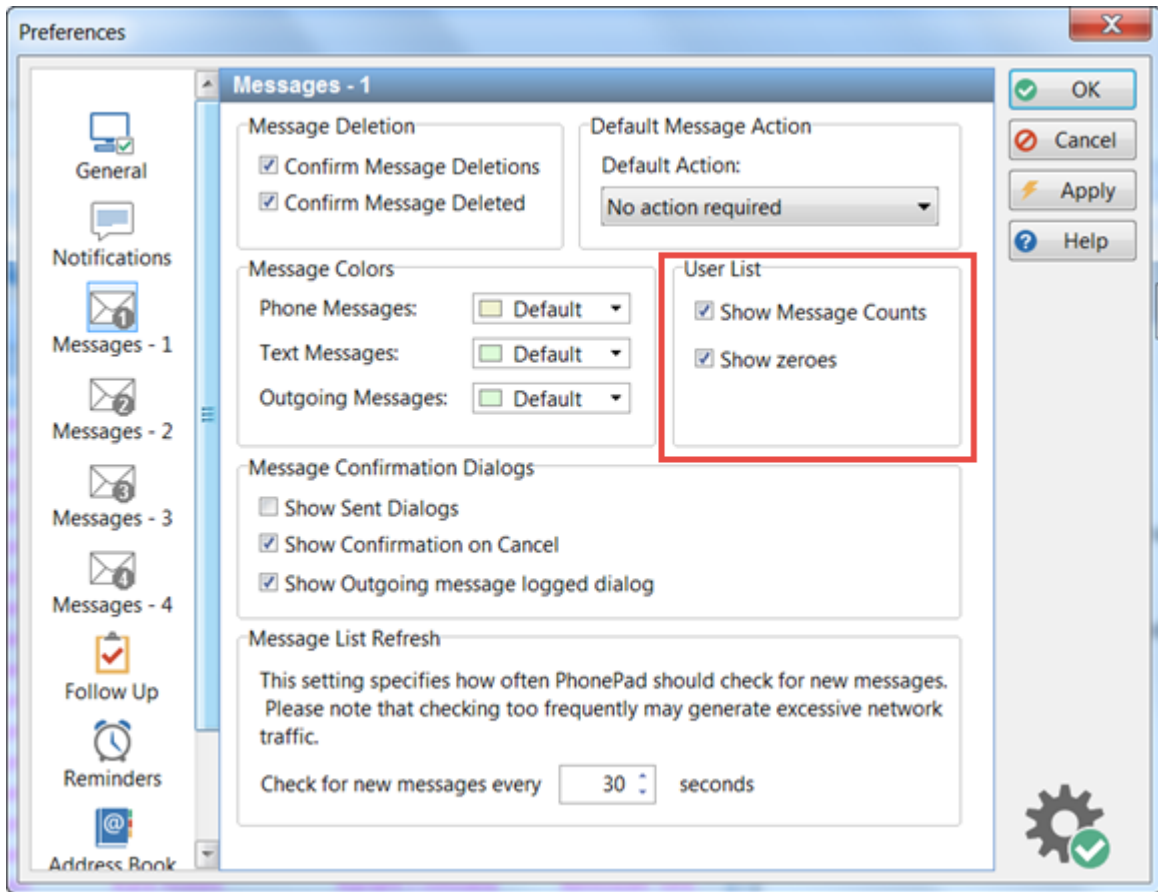

User List	
Show Message Counts	When checked, the User List will display message counts for Unread Messages and Uncompleted Follow Ups.
Show Zeroes	When checked, and Show Message Counts is checked as well, zeroes will be displayed where the user has no Unread Messages and/or Uncompleted Follow Ups. If unchecked, blank spaces will be shown instead of zeroes.

Message Filtering

The Inbox has a special option that none of the other folders have. It has the ability to filter messages, showing only the messages you want to see.

You can filter the Inbox by selecting a filter from the **Message Filter** menu.

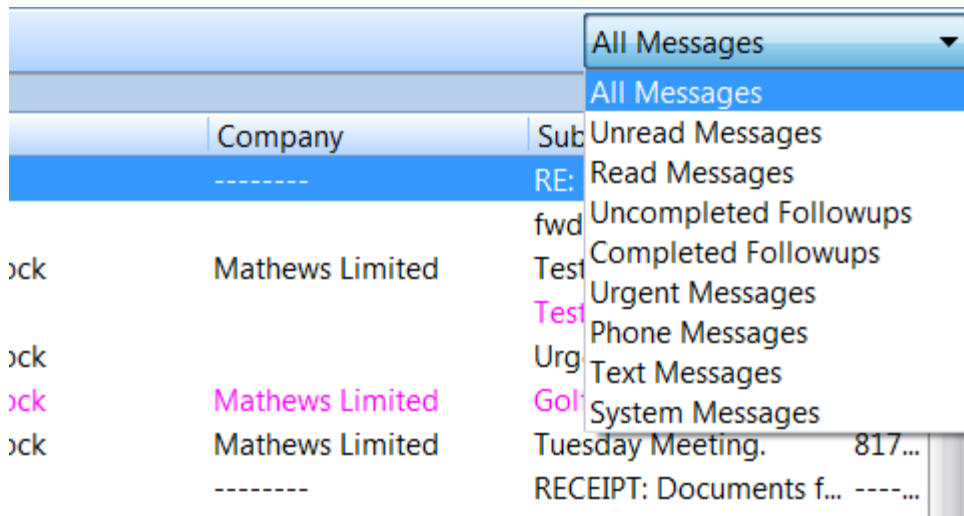



You can also choose a filter by selecting **Inbox Filtering** from the **File** menu. In this example only unread messages are displayed.

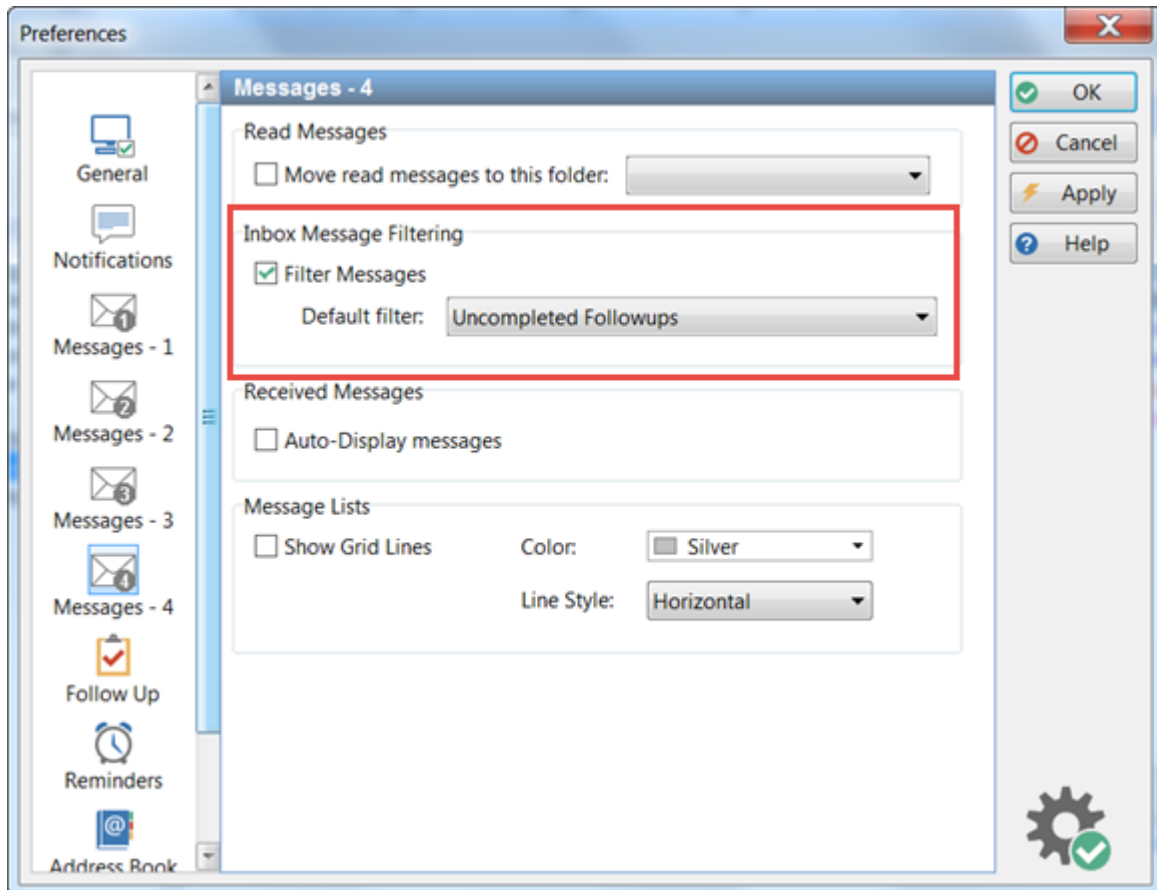

You can tell PhonePad to default to one of the filters on startup. For instance some users prefer to see only new messages on startup, or they want to see the messages they have to follow up first.

You can set a default filter by selecting **Preferences** from the **Tools** menu, and then selecting **Messages-4**. Check the **Filter Messages** check box and then select a default filter to use.



 There is a quick and easy way to filter messages by Unread Messages, Read Messages and All Messages. In the status bar it shows how many Unread and Read messages there are in your Inbox, as well as the total number of messages. You can click any of these to apply the relevant filter.

Unread: 4 Read: 17 Total: 21   2 Friday, 22 January 2016 3:04 pm

Outgoing Folder

All of your Outgoing call messages are stored in the Outgoing folder.

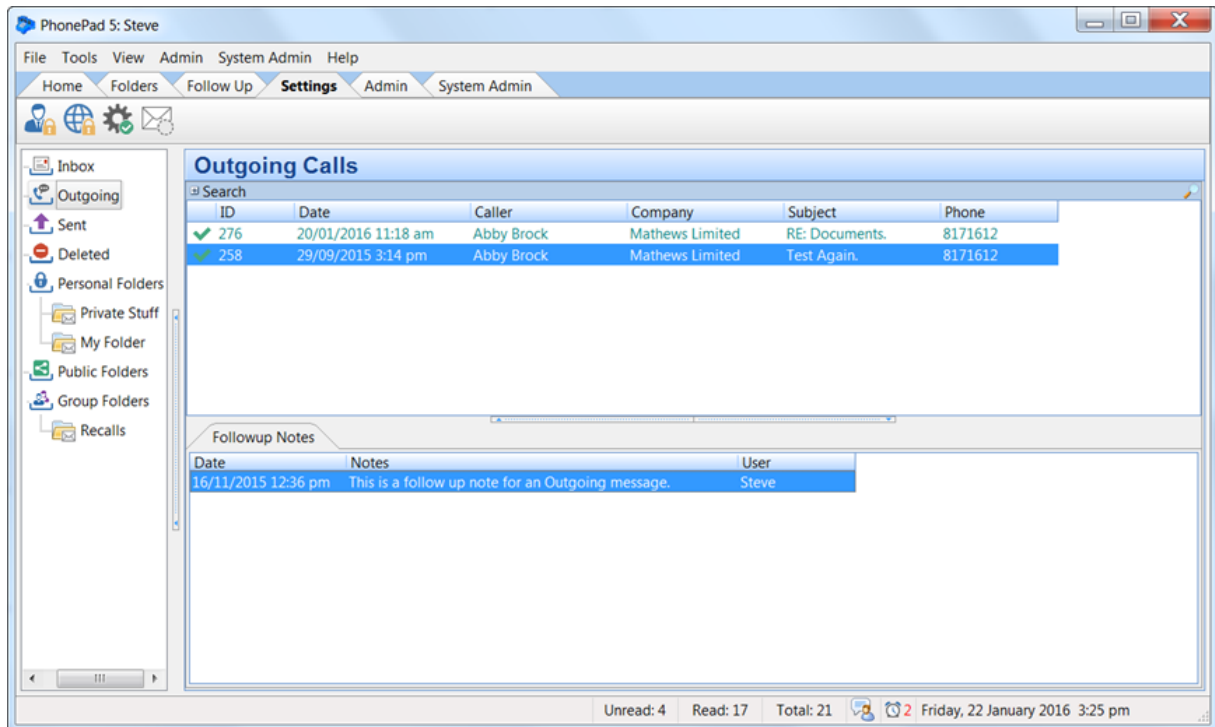

Sent Folder

Whenever you send a message to someone in PhonePad, it keeps a record of the message. These messages are stored in your **Sent** folder.

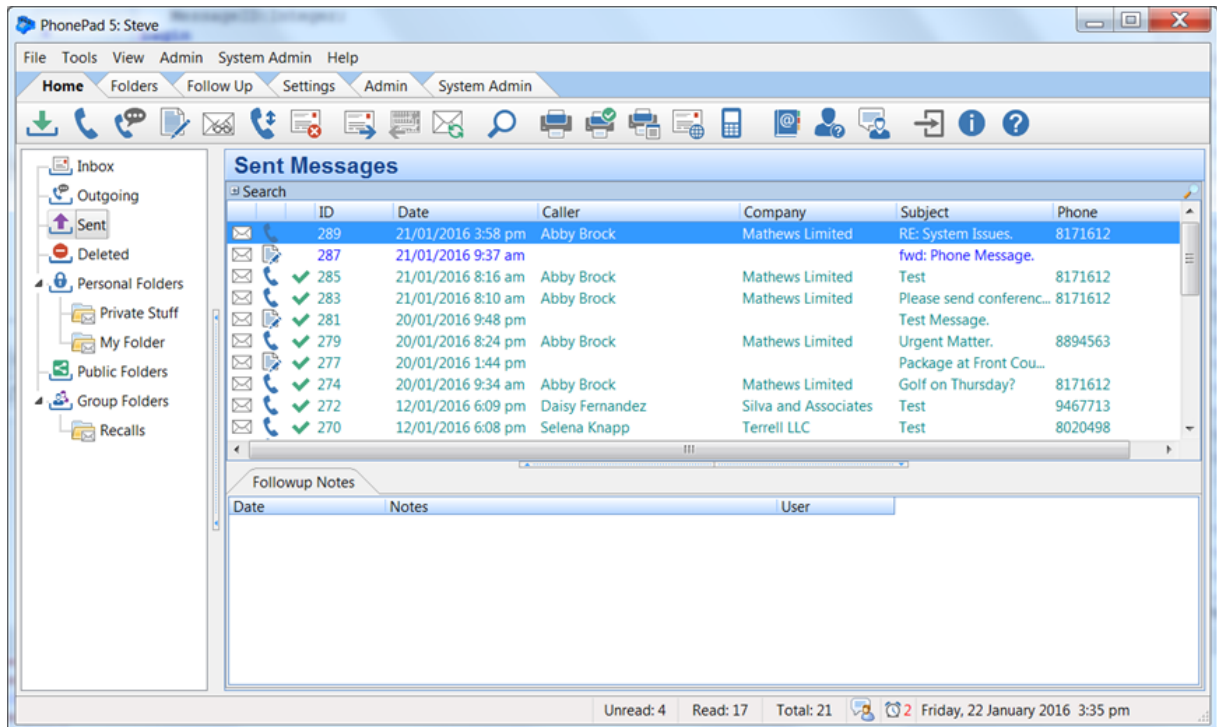

These messages can be forwarded to someone else, or you can resend a message you've sent before.

Deleted Folder

Every time you delete a message in PhonePad it winds up in the **Deleted** folder. Think of it as a trash can or rubbish bin. Messages stay in there until someone empties the bin, or until the system automatically empties it for you.

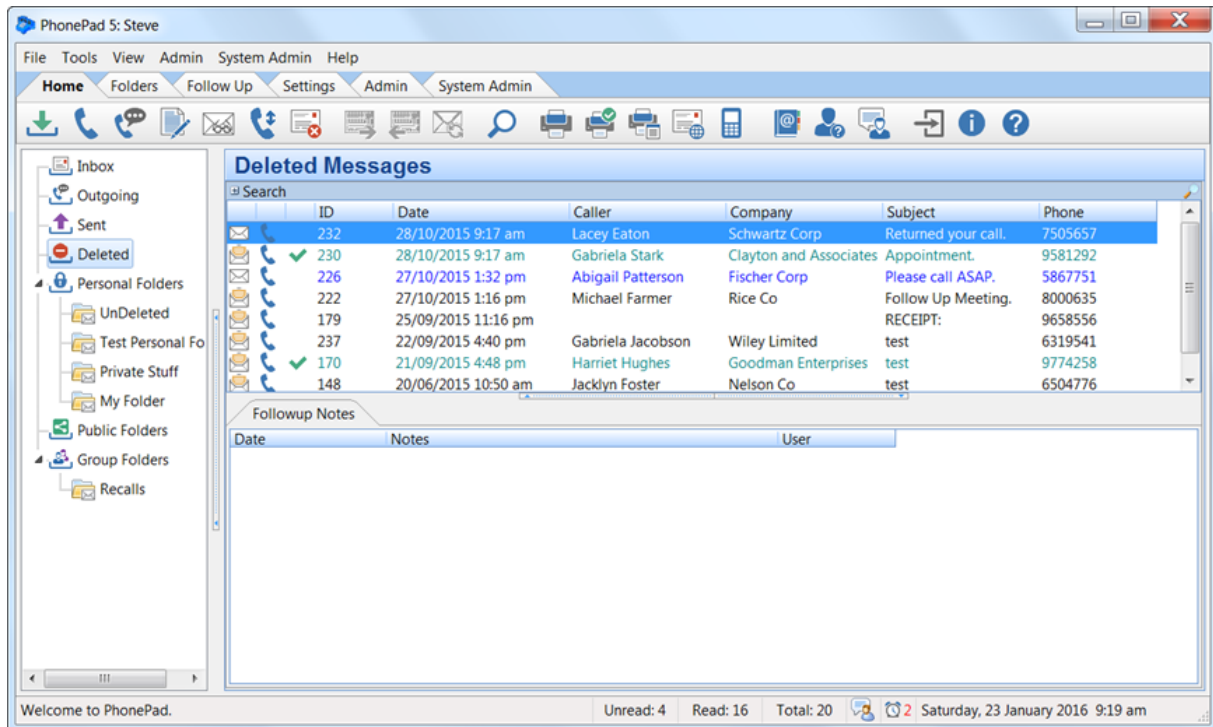

You can undelete messages in the **Deleted** folder.

You can also delete messages in the **Deleted** folder. A word of warning though: messages deleted from the Delete folder are **permanently** deleted. There is no way to retrieve them once you have done this.

If you decide that you need to retrieve a deleted message, you have up to 14 days to undelete it. The server will automatically delete messages that have been in **Deleted** folders for more than 14 days.



When you undelete a file it is returned to the folder it was deleted from. However, in the case of **Personal** and **Public** folders, if the folder has been deleted then there is nowhere for them to return to. In this situation PhonePad will automatically create a folder called **Undeleted** and place the messages there.

Personal Folders

Personal Folders can be used to organize your messages. Once you have finished with a message in your Inbox you can move it to a personal folder so that you can access it in the future.

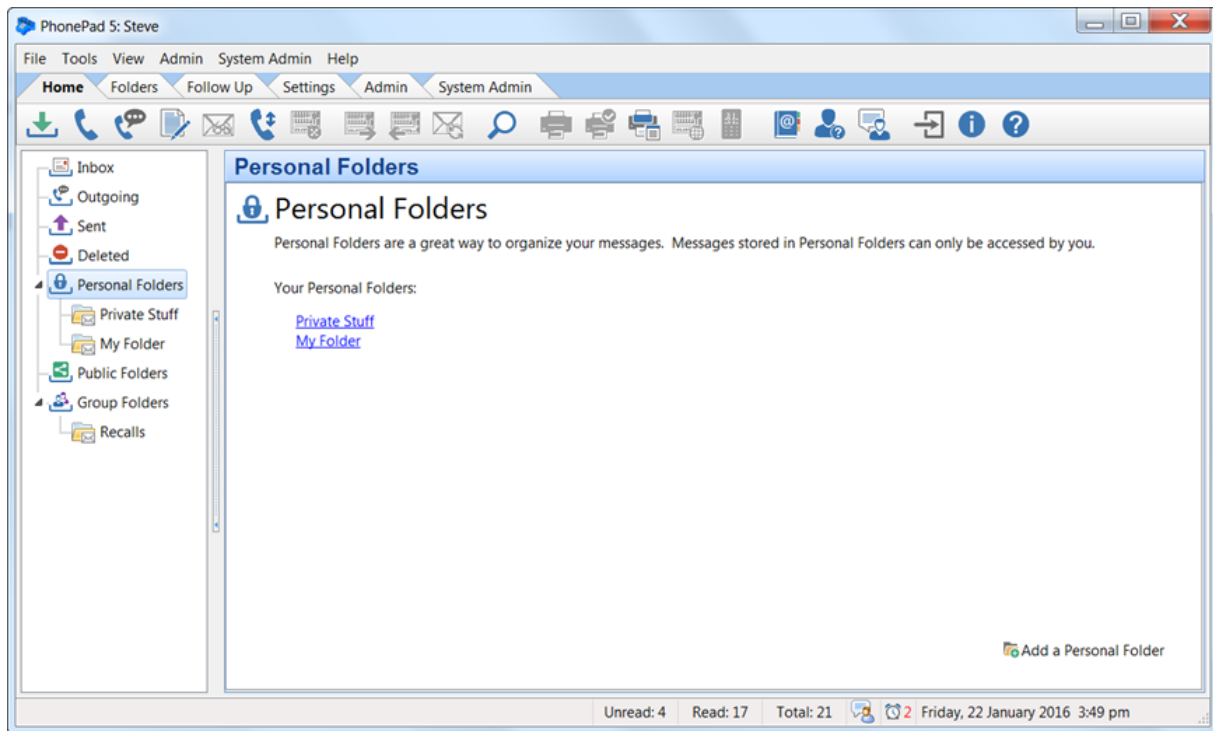

Adding a Personal Folder

Select **Personal Folders** in the folder tree and click the **Add a Personal Folder** link, or select the **Folders** tab on the toolbar and select **Add New Folder**, or right-click on **Personal Folders** in the folder tree and select **Add Folder** from the popup menu.

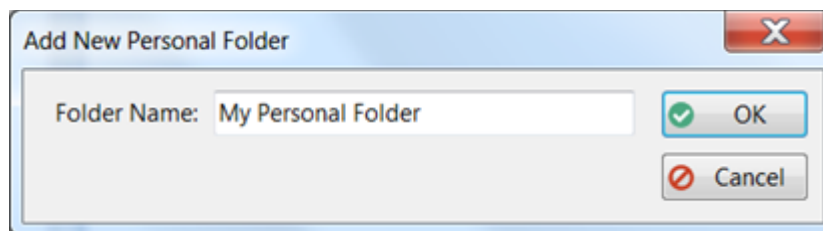

Enter a name for the folder and then click **OK**.

Editing a Personal Folder

Right-click on the folder in the folder tree, then select **Edit Folder** from the popup menu, or double-click on the folder in the folder tree, or or select the **Folders** tab on the toolbar and select **Edit Folder**.

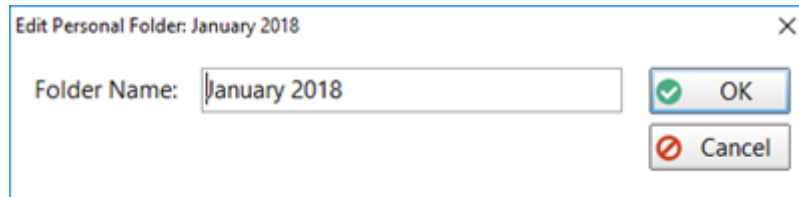

Click **OK** to save your changes.

Deleting a Personal Folder

Right-click on the folder in the folder tree, then select **Delete Folder** from the popup menu, or select the **Folders** tab on the toolbar and select **Delete Folder**.

You will be asked to confirm the deletion.

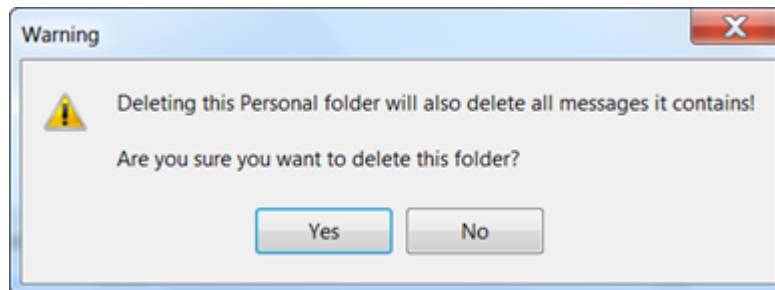

Any messages in the folder will also be deleted. The deleted messages will appear in the **Undeleted** folder.

If you decide to undelete messages that were previously in a folder that has been deleted, the messages will be added to a Personal folder called **UnDeleted**. If the folder doesn't exist then PhonePad will automatically create it.

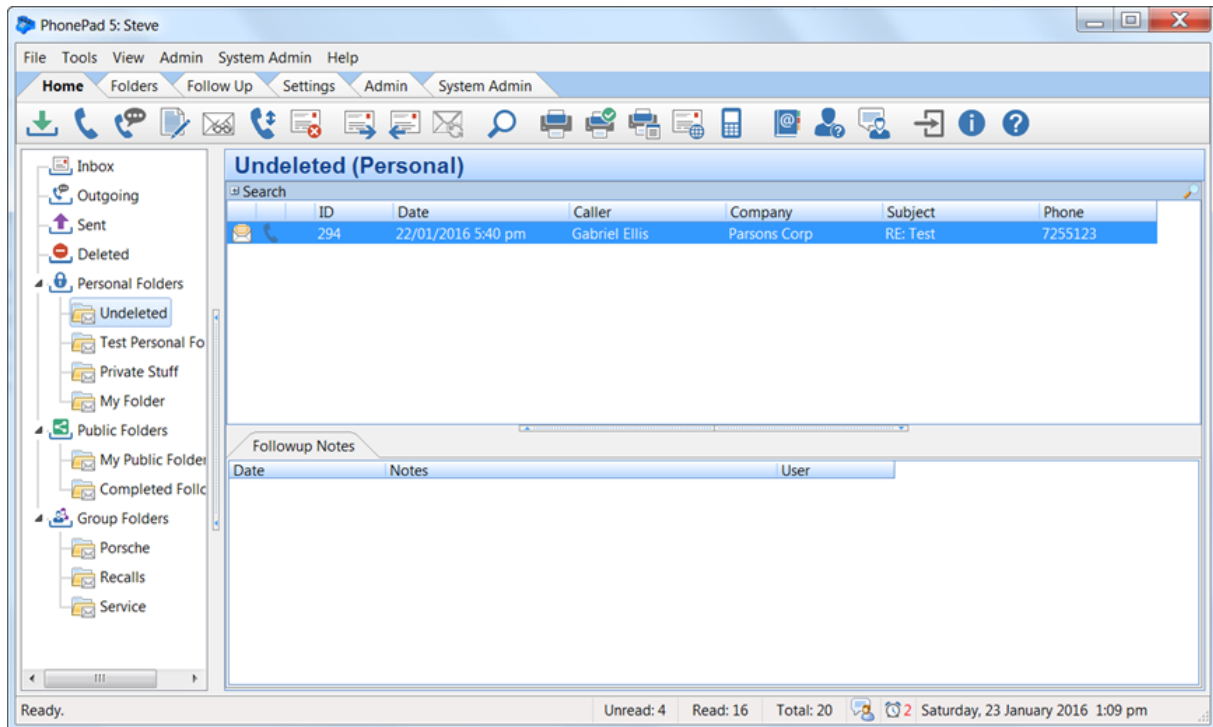

Emptying a Personal Folder

If you want to delete all messages in a Personal folder, right-click on the folder in the folder tree, then select **Empty Folder** from the popup menu, or select the **Folders** tab on the toolbar and select **Empty Folder**.

You will be asked to confirm the deletion.

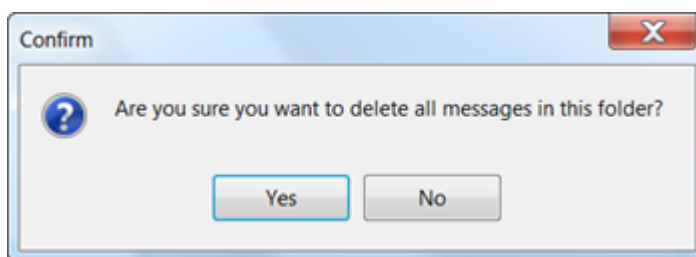

Accessing a Personal Folder

You can access your Personal folders by selecting the folder from the folder tree, or by clicking the link for the folder on the Personal Folders home page.

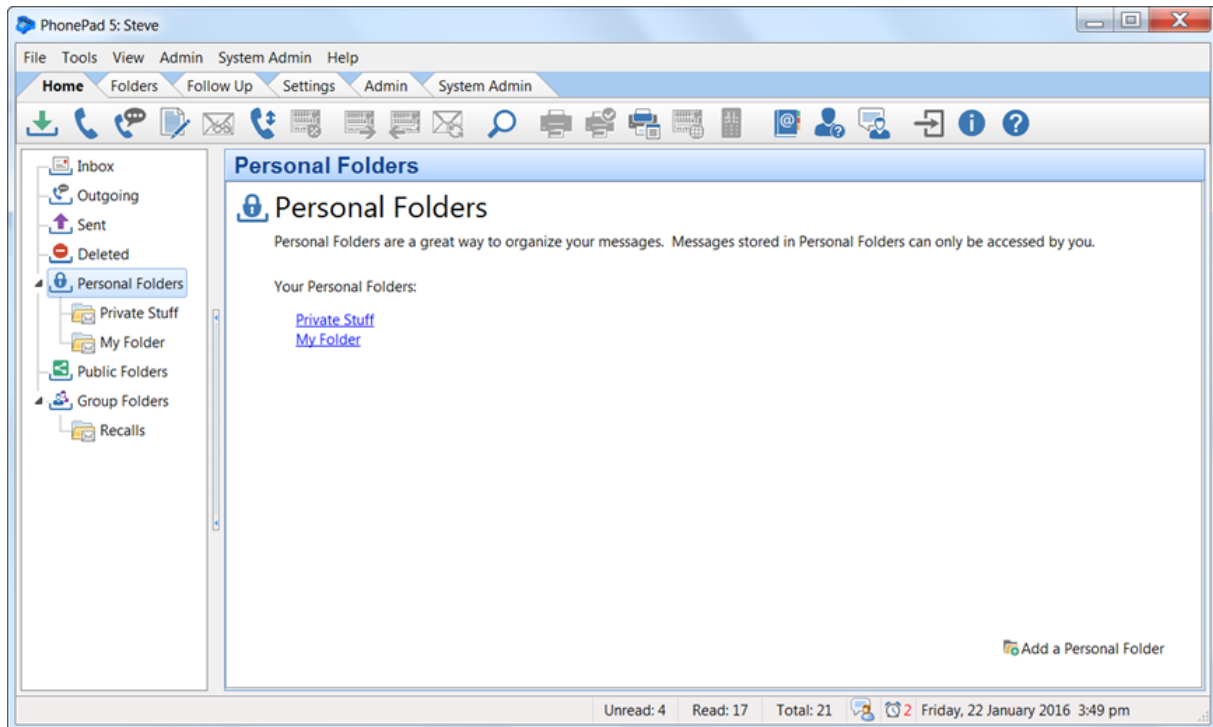

Changing a Personal Folder to a Public Folder

You can easily change a Personal Folder to a Public Folder by right-clicking on the Personal Folder and then selecting **Change to Public Folder** from the popup menu.

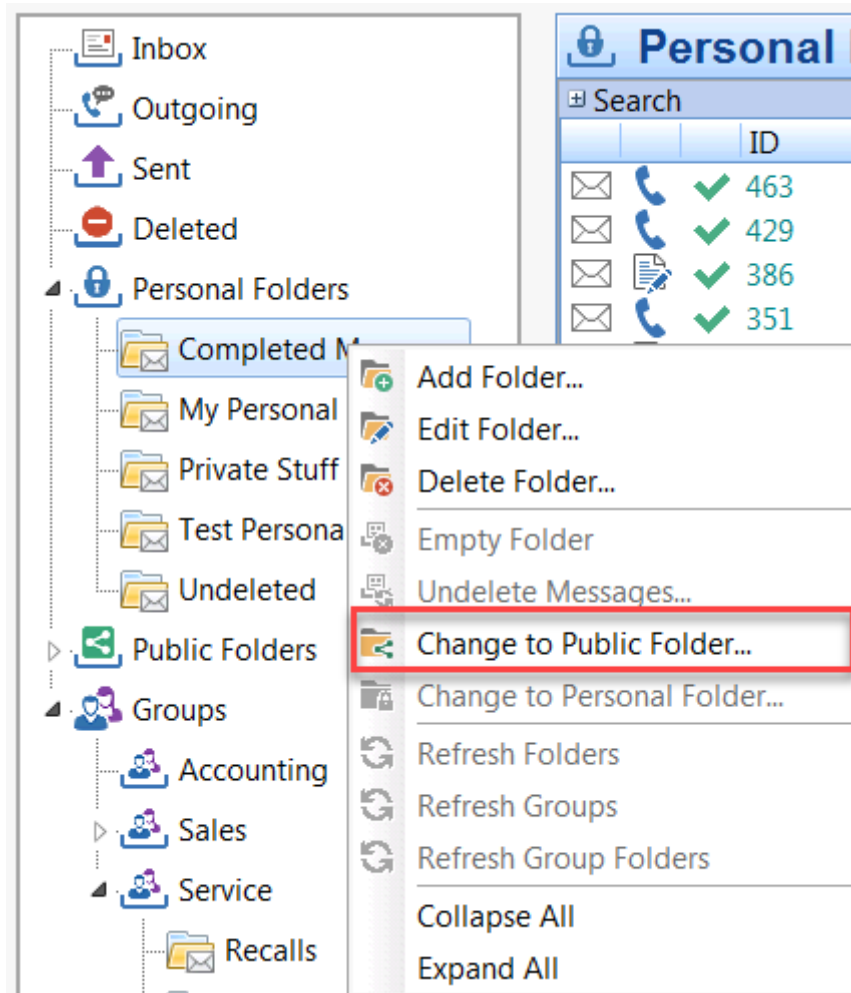

Public Folders

As the name suggests, Public folders are accessible by any PhonePad user. Public folders are used to store messages that can be accessed by everyone.

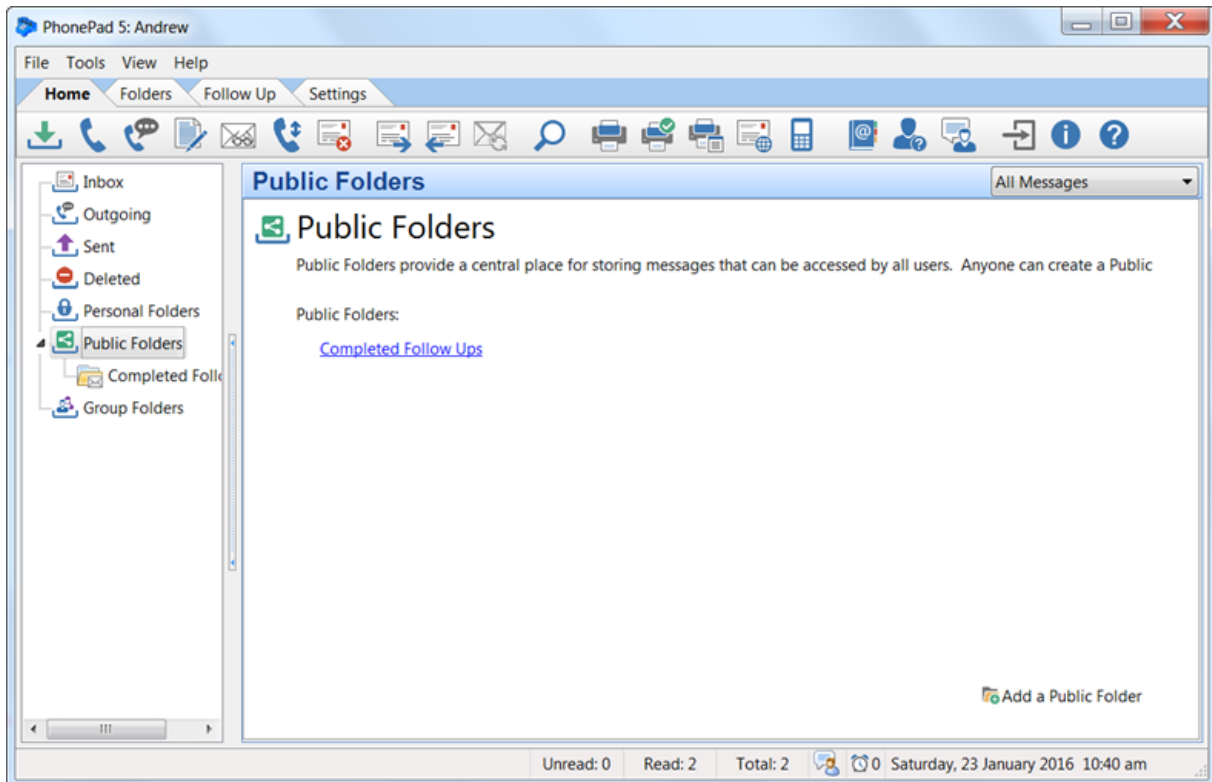

Adding a Public Folder

Select **Public Folders** in the folder tree and click the **Add a Public Folder** link, or select the **Folders** tab on the toolbar and select **Add New Folder**, or right-click on **Public Folders** in the folder tree and select **Add Folder** from the popup menu.

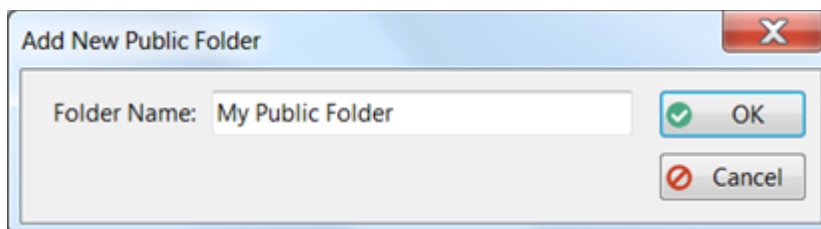

Enter a name for the folder and then click **OK**.

Editing a Public Folder

Right-click on the folder in the folder tree, then select **Edit Folder** from the popup menu, or double-click on the folder in the folder tree, or select the **Folders** tab on the toolbar and select **Edit Folder**.

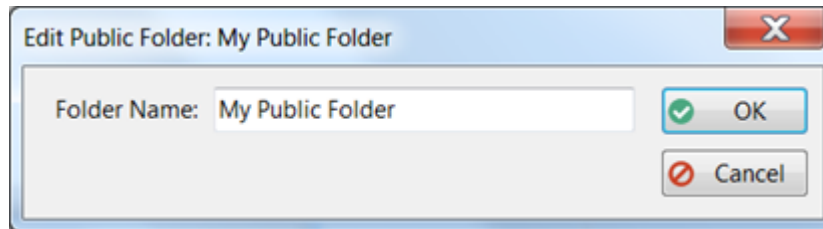

Click **OK** to save your changes.

Deleting a Public Folder

Right-click on the folder in the folder tree, then select **Delete Folder** from the popup menu, or select the **Folders** tab on the toolbar and select **Delete Folder**.

You will be asked to confirm the deletion.

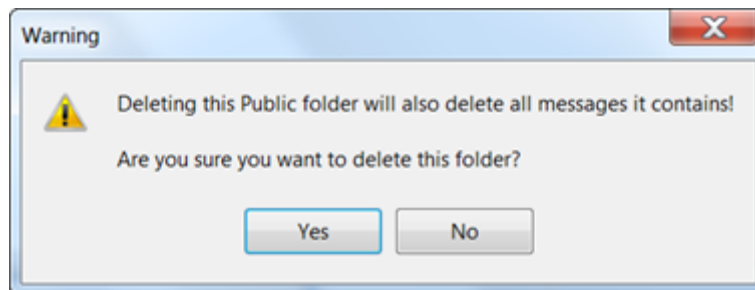

Any messages in the folder will also be deleted. The deleted messages will appear in the **Undeleted** folder.

If you decide to undelete messages that were previously in a folder that has been deleted, the messages will be added to a Personal folder called **Undeleted**. If the folder doesn't exist then PhonePad will automatically create it.

If you didn't create the Public folder then you will not be able to delete it, unless you are an administrator.

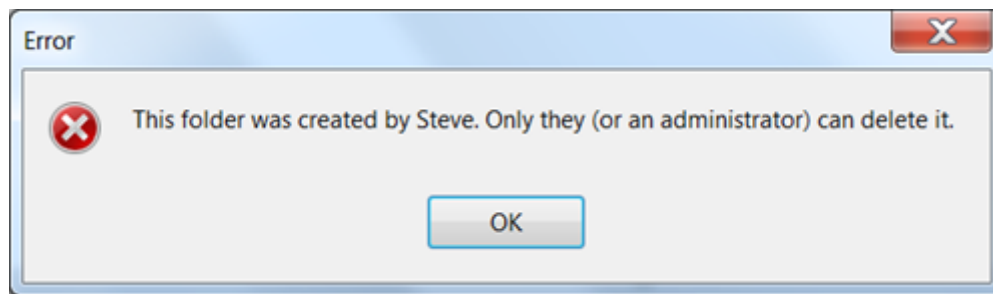

Emptying a Public Folder

If you want to delete all messages in a Public folder, right-click on the folder in the folder tree, then select **Empty Folder** from the popup menu, or select the **Folders** tab on the toolbar and select **Empty Folder**.

You will be asked to confirm the deletion.

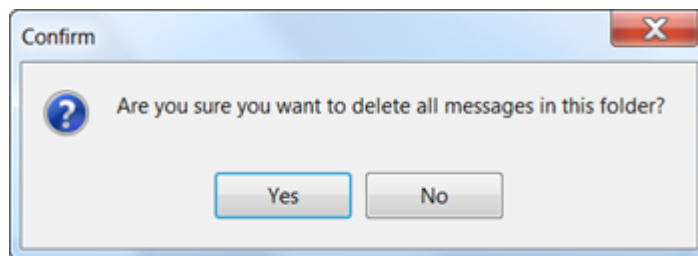

Accessing a Public Folder

You can access your Public folders by selecting the folder from the folder tree, or by clicking the link for the folder on the **Public Folders** home page.

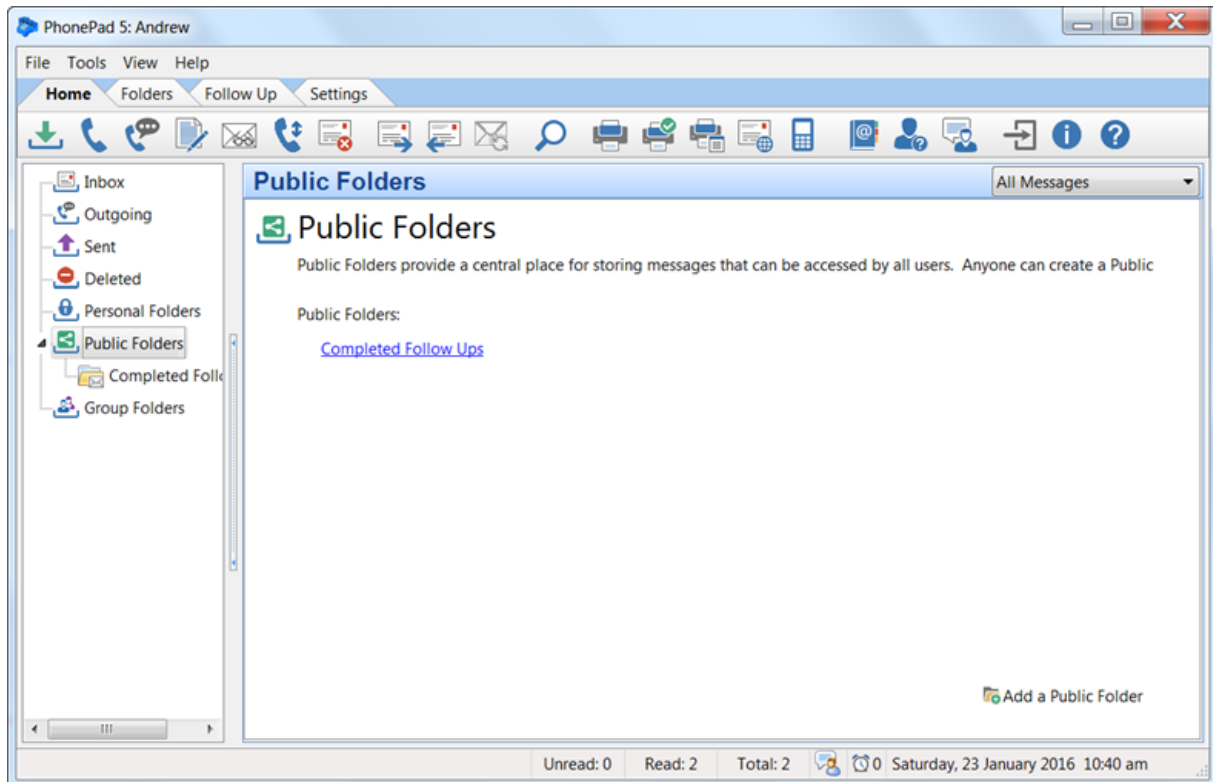

Changing a Public Folder to a Personal Folder

You can easily change a Public Folder to a Personal Folder by right-clicking on the Personal Folder and then selecting **Change to Personal Folder** from the popup menu.

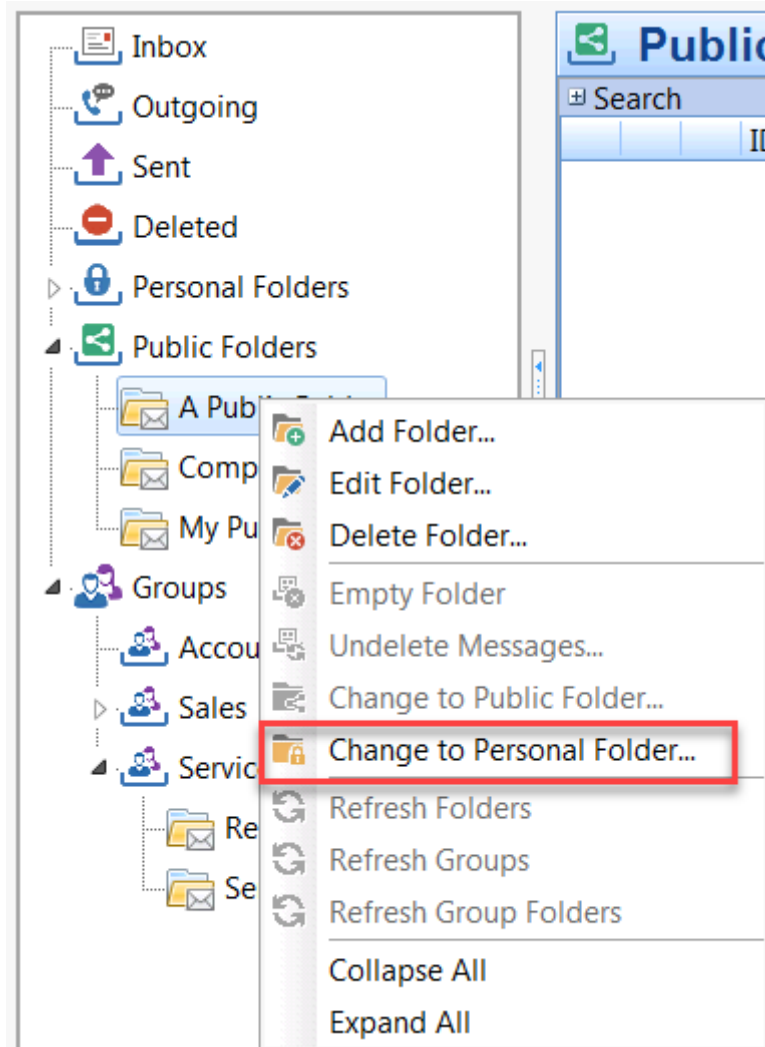

Group Folders

Group folders are similar to Public folders in that they are shared folders, but they can only be accessed by members of the group the folders belong to. You have to be given access to a Group folder by an administrator.

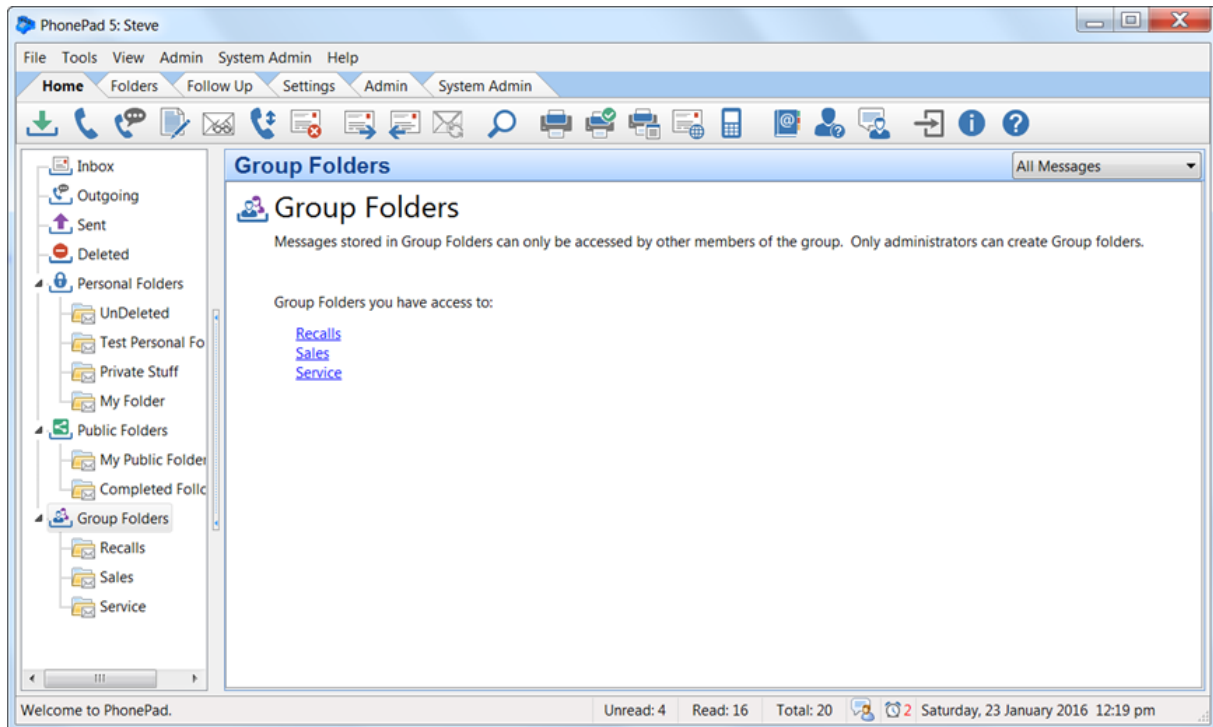

Only administrators can add, edit and delete Group folders. Group folders can also be added, edited and deleted using the **Manage Groups** option on the **Admin** toolbar.

Adding a Group Folder

Select the **Folders** tab on the toolbar and select **Add New Folder**, or right-click on **Group Folders** in the folder tree and select **Add Folder** from the popup menu.

1. Select the **Group** the folder will belong to. Only members of that Group will be able to access this folder.

2. Enter a **Folder Name**.
3. Enter a **Description** if you wish.
4. Click **OK**.

Editing a Group Folder

Right-click on the folder in the folder tree, then select **Edit Folder** from the popup menu, or double-click on the folder in the folder tree, or or select the **Folders** tab on the toolbar and select **Edit Folder**.

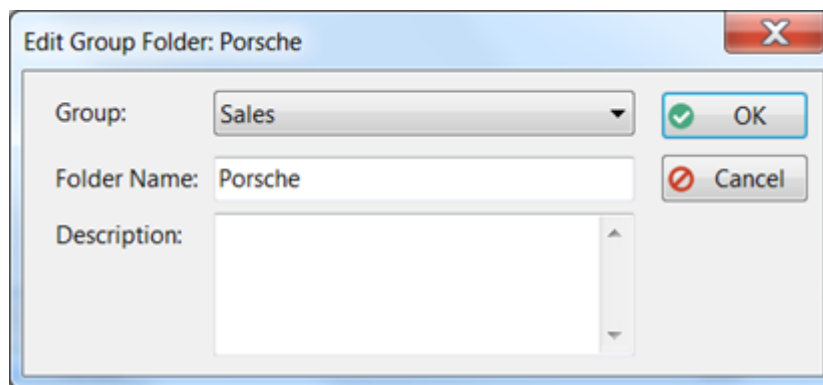

Make any required changes and then click **OK** to save them.

Deleting a Group Folder

Right-click on the folder in the folder tree, then select **Delete Folder** from the popup menu, or select the **Folders** tab on the toolbar and select **Delete Folder**.

You will be asked to confirm the deletion.

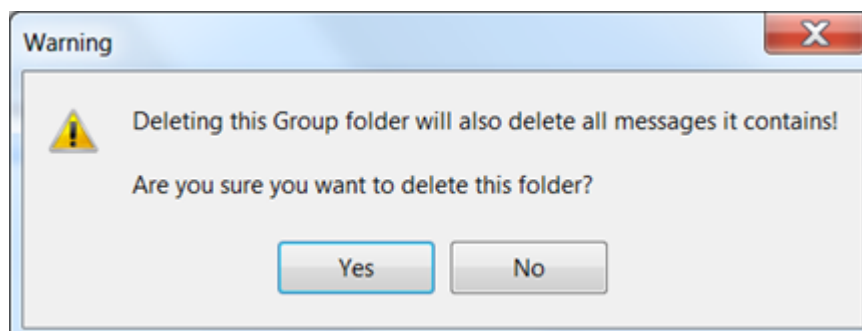

Any messages in the folder will also be deleted. The deleted messages will appear in the **Deleted** folder.

If you decide to undelete messages that were previously in a folder that has been deleted, the messages will be added to a Personal folder called **Undeleted**. If the folder doesn't exist then PhonePad will automatically create it.

Emptying a Group Folder

If you want to delete all messages in a Group folder, right-click on the folder in the folder tree, then select **Empty Folder** from the popup menu, or select the **Folders** tab on the toolbar and select **Empty Folder**.

You will be asked to confirm the deletion.

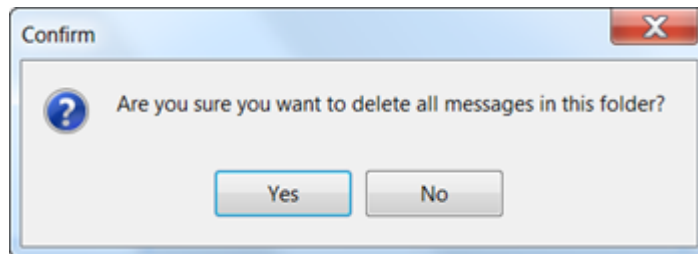

Accessing a Group Folder

You can access your Group folders by selecting the folder from the folder tree, or by clicking the link for the folder on the **Group Folders** home page.

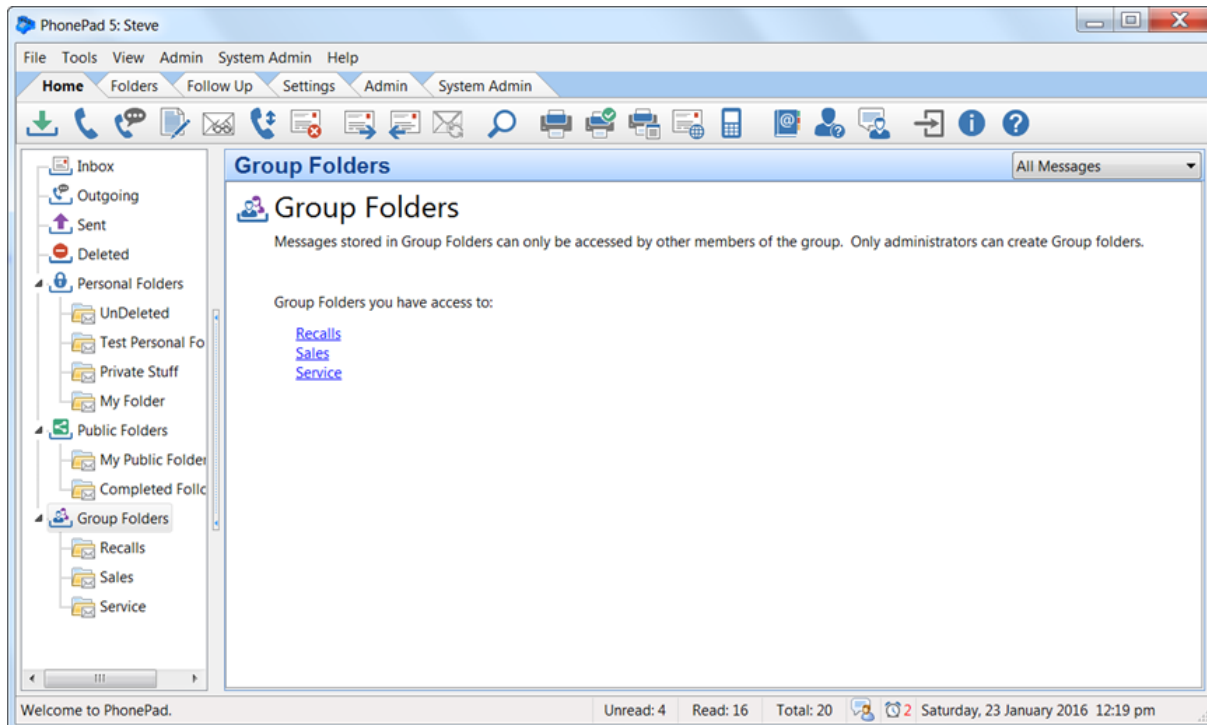

Sub-Folders

Personal and Public folders can have sub folders. You can go down as many levels as you want although it's recommended to not have more than 3 levels as it can be unwieldy to manage.

Sub-folders are added, edited and deleted in the same way as top-level folders.

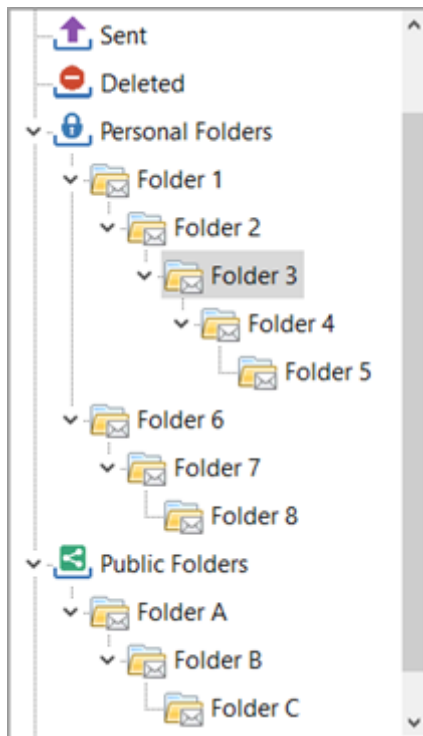

Adding a Sub-Folder

Select **Personal Folders** in the folder tree and click the **Add a Personal Folder** link, or select the **Folders** tab on the toolbar and select **Add New Folder**, or right-click on **Personal Folders** in the folder tree and select **Add Folder** from the popup menu.

Parent Folder Name:	My Messages	OK
Sub-Folder Name:	January 2018	Cancel
		Help

The Parent Folder Name will be shown but it cannot be edited in this window.

Enter a name for the new sub-folder and then click **OK**.

Editing a Sub-Folder

Right-click on the folder in the folder tree, then select **Edit Folder** from the popup menu, or double-click on the folder in the folder tree, or select the **Folders** tab on the toolbar and select **Edit Folder**.

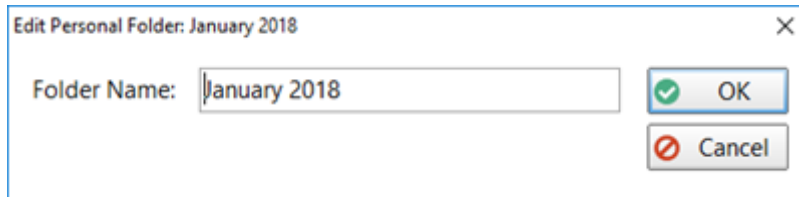

Click **OK** to save your changes.

Undeleted Folder

The **Undeleted** folder is a special Personal folder automatically created by PhonePad. The best way to explain how it works is to give an example:

You have a number of messages in a Personal or Public folder and decide to delete that folder. Any messages that are in that folder will be deleted as well. Deleted messages always end up in the **Deleted** folder of the user that deleted them.

If you decide to undelete any of these messages they have no place to be undeleted to as the folder no longer exists. PhonePad solves this by placing the messages in an **Undeleted** folder. If the folder doesn't exist PhonePad will create it. You can then move these messages to another folder.

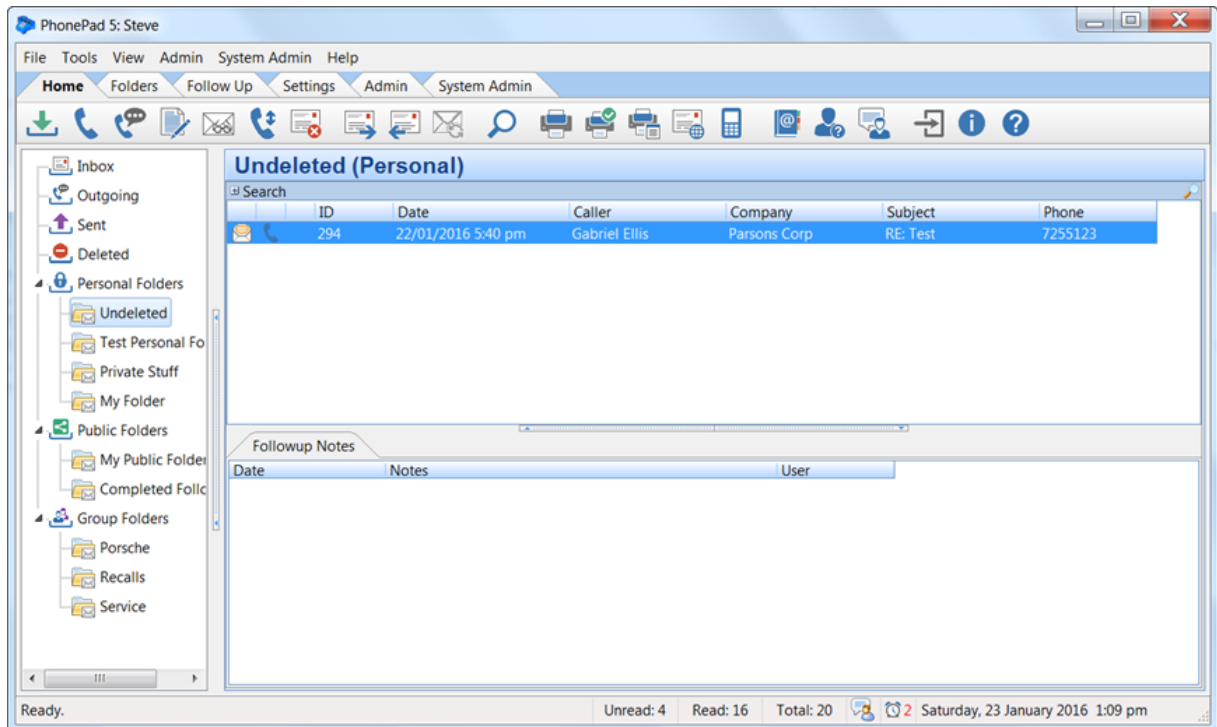

Moving Messages

To move messages from one folder to another, select the message(s) and click the **Move Messages to Folder** button on the **Folders** tab of the toolbar, or right-click on the message and select **Move to Folder** from the popup menu.



The following window will be displayed:

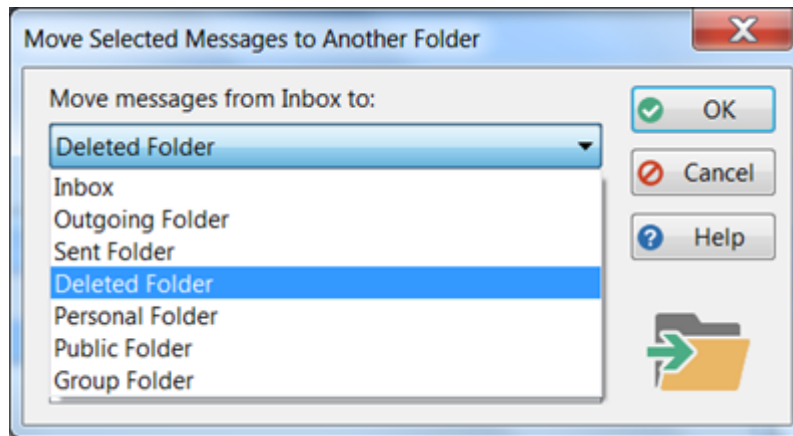

If you select Personal Folder, Public Folder or Group Folder, you will also need to select the relevant folder:

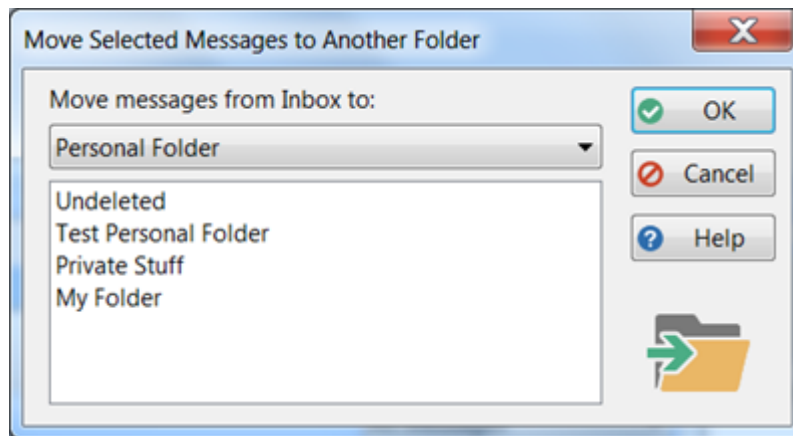

Click **OK** to move the selected message(s).

Drag and Drop Your Messages

A quicker and possibly better alternative is to use drag and drop to move messages between folders. Simply select the messages you want to move, then while holding the **<alt>** key and **left mouse button** down drag them to another folder, and then release the mouse button.

Moving Folders

Folders can be moved by dragging and dropping them. Simply select the folder you want to move, then while holding the **<alt>** key and **left mouse button** down drag it to another folder, and then release the mouse button.

Folders can be dragged and dropped within Personal Folders and Public Folders. They can also be dragged from Personal Folders to Public Folders, and vice versa.

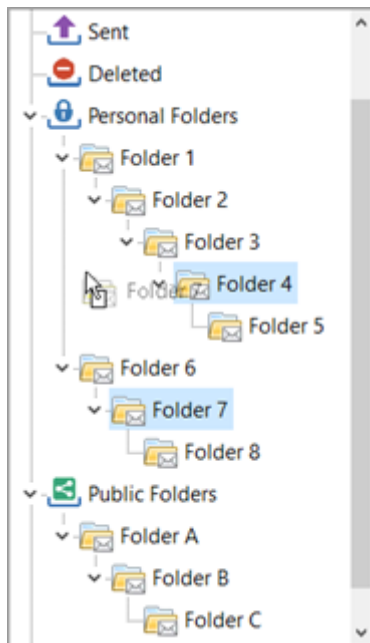

Folder Message Counts

The Folder Tree can optionally display the number of messages in each folder.

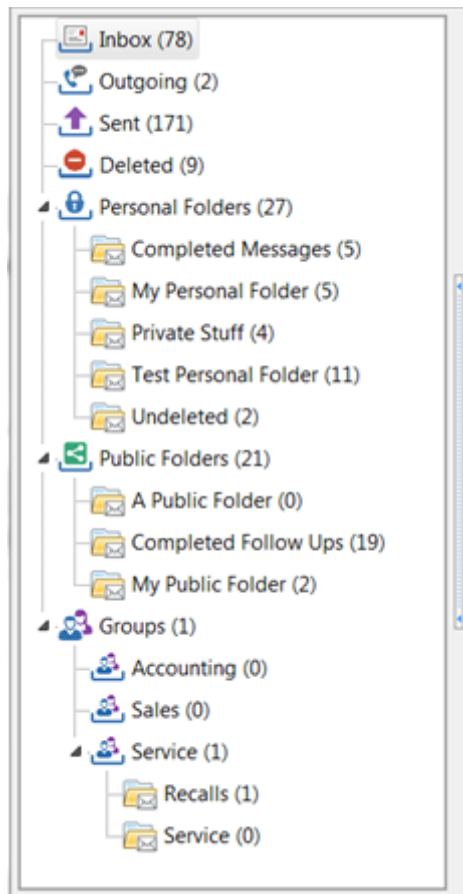

The **Inbox**, **Outgoing**, **Sent** and **Deleted** folders will display the total number of messages in each folder respectively.

Personal Folders will display the total number of messages in *all* personal folders you have, while each personal folder will show the total number of messages contained by that folder.

Public Folders will display the total number of messages in *all* public folders, while each public folder will show the total number of messages contained by that folder.

Groups will show the total number of messages across all groups that you are a member of. Each group will display the total number of messages for all group folders under it, and each group folder will show the total number of messages it contains.

To show or hide message counts, select **Preferences** from the **View** menu, then select **Messages-4**. Check or uncheck the **Show Message Counts** checkbox.

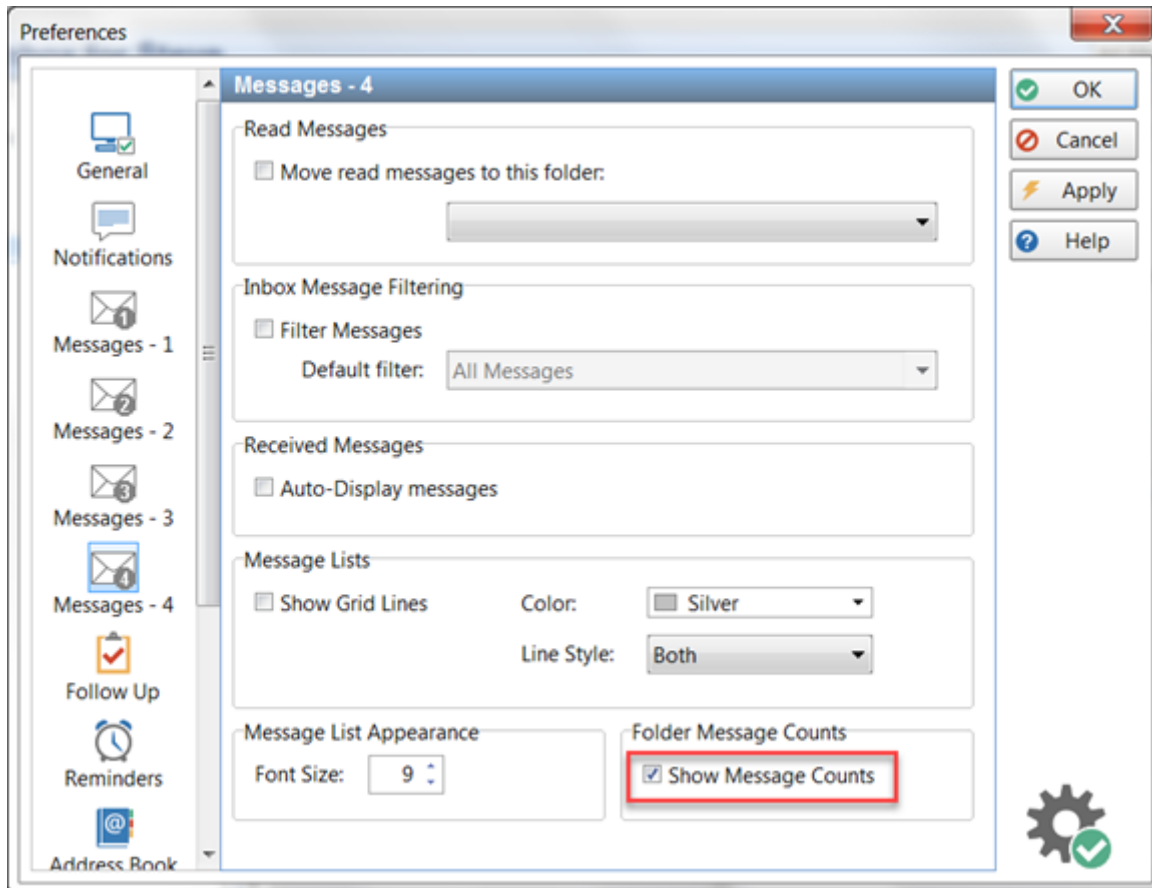

Searching Folders

If you end up with a lot of folders and sub-folders it may be difficult to find the folder you're after. Fortunately the Folder Tree has a search option located at the bottom of the tree.

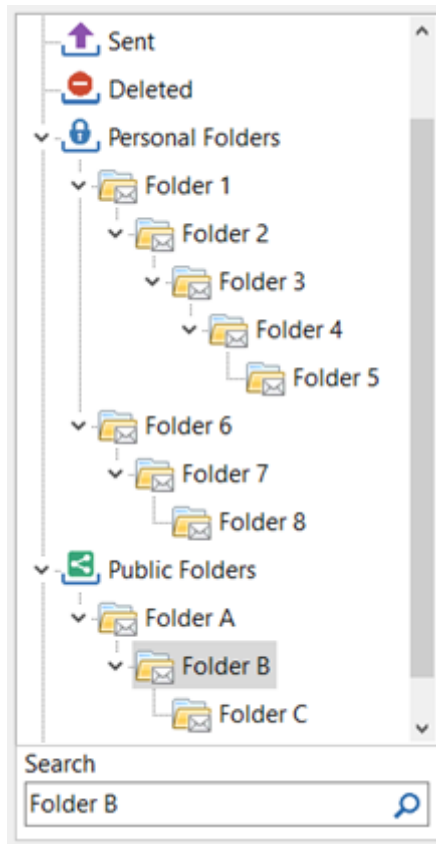

Enter search text and click the search button.

If more than one occurrence of the text is found you can click the search button to navigate to the next folder. Once you reach the last occurrence found the search will wrap around to the first one again.

Navigation Bar

If you have a lot of sub-folders it can be easy to forget where you are hierarchy and also to navigate to a folder further up the line. That's where the Folder Navigation Bar comes in handy.

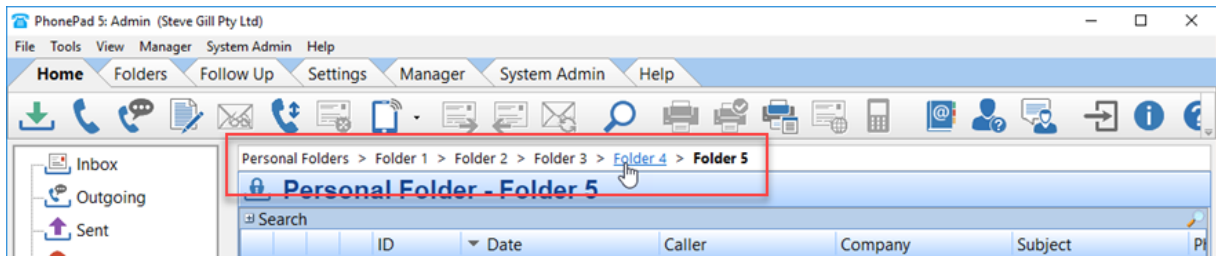

The Navigation Bar shows which folder you current have selected in bold. You can easily navigate up the tree by selecting a folder above the selected folder. For example, in the screenshot above we have Folder 5 selected. If we hover the mouse button over Folder 4 it becomes highlighted. Clicking on the folder name will take you to that folder.

The Navigation Bar is only visible when you have either Personal or Public folders selected.

Chapter

6

Following Up

Following Up

PhonePad's Follow Up features provide a way of tracking and managing your calls more effectively. They ensure that calls are returned when they should be and that none fall between the cracks.

The Follow Up features include the ability to:

- Mark messages to be followed up.
- Mark messages when follow up has been completed.
- Keep extensive Follow Up notes.
- Set reminders to follow up calls and to alert you when they are overdue.
- Automatically set follow ups

Mark Messages for Follow Up

You can mark messages to be followed up so that you can easily identify them in your message lists.

To mark a message for follow up, select the message and then click the **Mark for Follow Up** button on the **Follow Up** tab on the toolbar, or select **Follow Up/Mark for Follow Up** from the **File** menu.



When you mark a message for follow up, an icon will be displayed next to the message. The message will also be highlighted in a different color. All users who received the message will also have their message marked for follow up.



Inbox		All Messages					
Search							
	ID	Date	Caller	Company	Subject	Phone	
  	284	21/01/2016 8:11 am	Abby Brock	Mathews Limited	Please send conferenc...	81716...	
 	271	12/01/2016 6:09 pm	Selena Knapp	Terrell LLC	Friday.	80204...	

Mark Follow Ups as Completed





Once you have completed a follow up, you can mark the message as completed.

To mark a message for follow up, select the message and then click the **Mark for Follow Up** button on the **Follow Up** tab on the toolbar, or select **Follow Up/Mark for Follow Up** from the **File** menu.

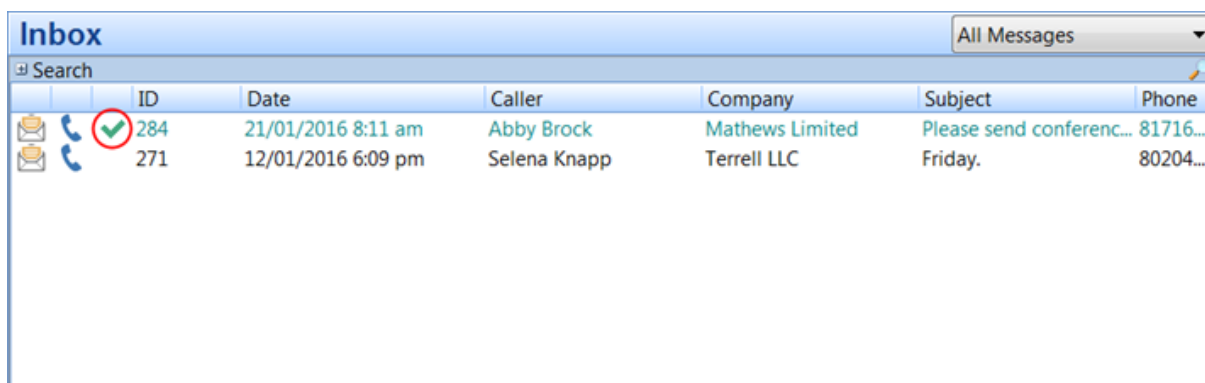

An icon will be displayed next to the message indicating that follow up has been completed.



Inbox		All Messages					
Search							
	ID	Date	Caller	Company	Subject	Phone	
  	284	21/01/2016 8:11 am	Abby Brock	Mathews Limited	Please send conferenc...	81716...	
 	271	12/01/2016 6:09 pm	Selena Knapp	Terrell LLC	Friday.	80204...	

All other users who received the same message will also have theirs marked as completed. This lets other users know that no further follow up action is required.

Unmarking a Message for Follow Up

A message that has been marked for Follow Up can be unmarked by selecting the message and then clicking the **Mark for Follow Up** button on the **Follow Up** tab on the toolbar, or by selecting **Follow Up/Mark for Follow Up** from the **File** menu.



When you unmark a message for follow up, any other user who received the same message will also have their message unmarked.

Automatically Marking Messages for Follow Up

Using **System Rules**, administrators can configure PhonePad to automatically mark all new messages for Follow Up.

Follow Up Notes

Follow Up Notes provide a way to keep comprehensive notes on all interaction with a caller. You can add notes on conversations you've had with callers, any follow up action such as call backs, messages left, etc.

Follow Up Notes are accessible by all users who have received the same message so it provides a great way to coordinate any follow up action between a group of users.

Add a Follow Up Note

To add a Follow Up Note, select a message and then click the **Add a Follow Up Note** button on the **Follow Up** tab on the toolbar, or select **Follow Up/Add Follow Up Note** from the **File** menu, or right-click on the Follow Up Notes area and select **Add Follow Up Note** from the popup menu.



The Add Follow Up Note window will be displayed.

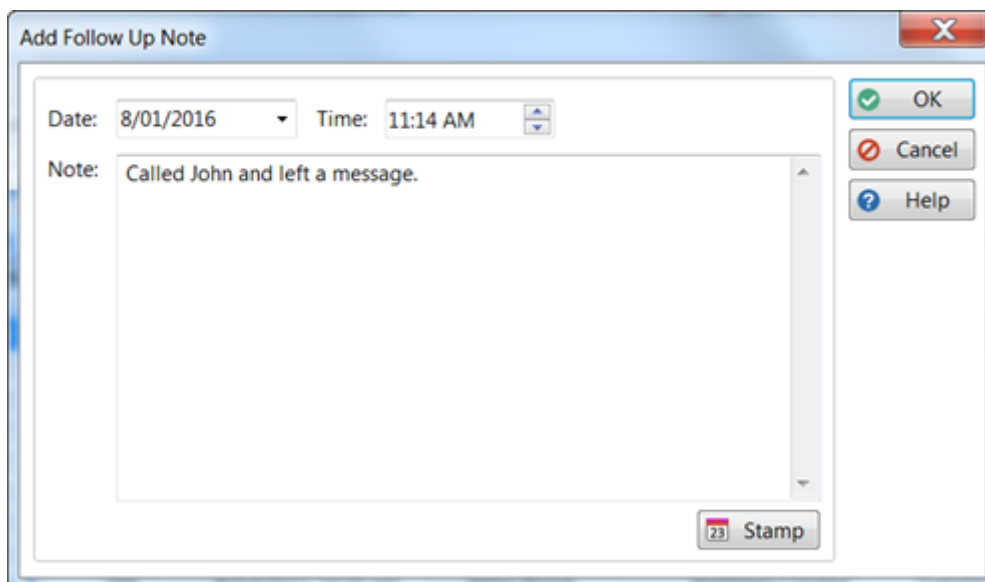

The date and time are automatically filled in for you, but they can be changed if required. Enter your comments in the Note area and then click **OK**.

The note will then appear under the Follow Up Notes tab.

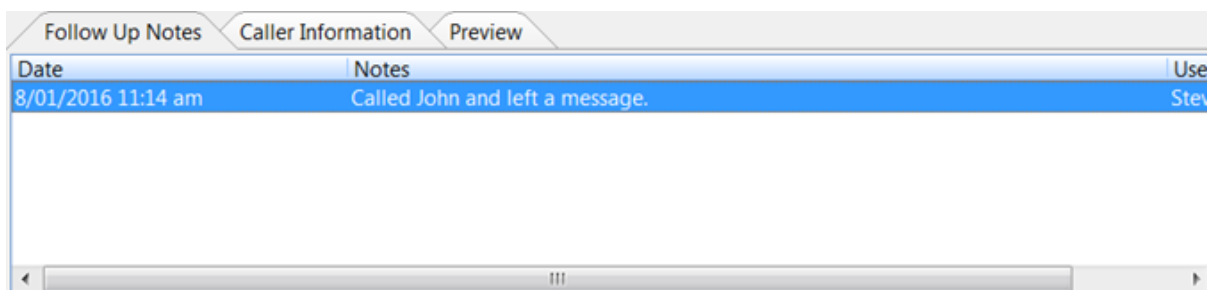

You can potentially add as many follow up notes as you like.

Edit a Follow Up Note

To edit a Follow Up Note, select a message and then click the **Edit a Follow Up Note** button on the **Follow Up** tab on the toolbar, or select **Follow Up/Edit Follow Up Note** from the **File** menu, or right-click on the Follow Up Notes area and select **Edit Follow Up Note** from the popup menu, or simply double-click on the follow up note.



If you create the follow up note you will be able to edit it. If you didn't create the follow up note then you will only be able to view it.

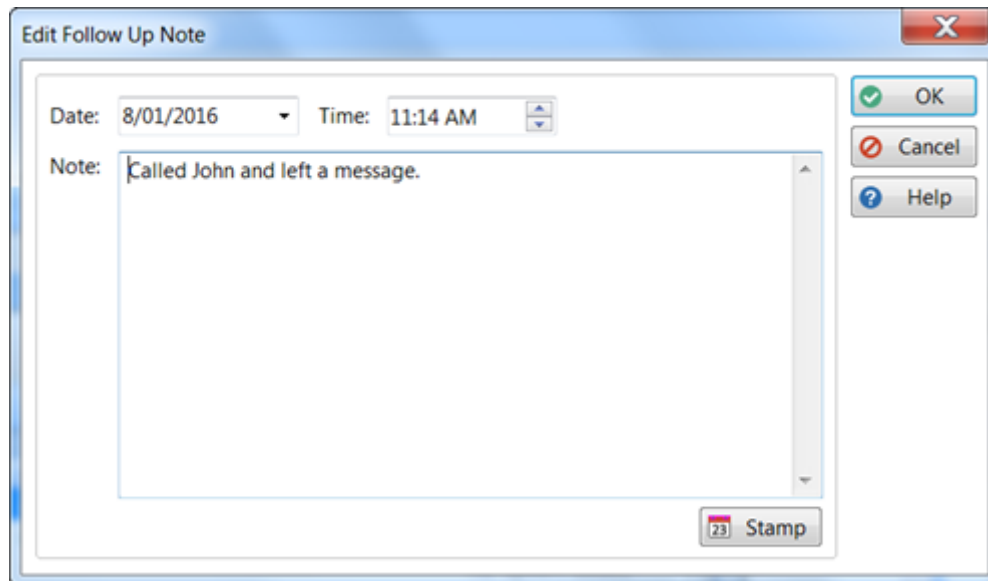

Make the required changes and then click **OK**.

Delete a Follow Up Note

To delete a Follow Up Note, select a message and then click the **Delete a Follow Up Note** button on the **Follow Up** tab on the toolbar, or select **Follow Up/Delete Follow Up Note** from the **File** menu, or right-click on the Follow Up Notes area and select **Delete Follow Up Note** from the popup menu.



You will be asked to confirm the deletion.

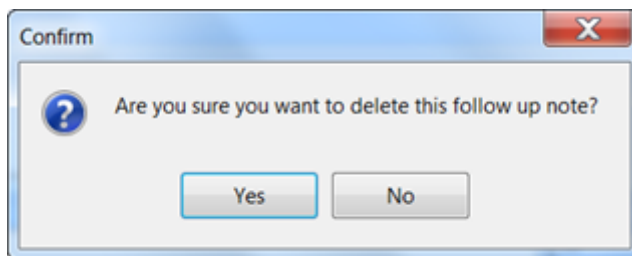

You can only delete follow up notes that you have created.

View a Follow Up Note

To view a Follow Up Note, select a message and then click the **View a Follow Up Note** button on the **Follow Up** tab on the toolbar, or select **Follow Up/View Follow Up Note** from the **File** menu, or right-click on the Follow Up Notes area and select **View Follow Up Note** from the popup menu.



The Follow Up Note will open.

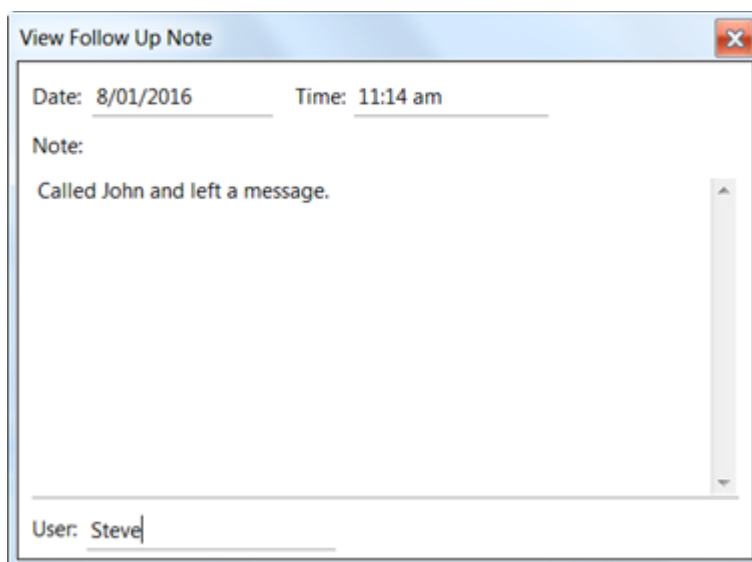

Printing Follow Up Notes

You can print all of the Follow Up Notes for a message. Right-click in the Follow Up Notes area and select **Print Follow Up Notes** from the popup menu.

Reminders

To ensure that follow ups are done in a timely manner you can set up reminders.

Adding a Reminder

To add a reminder, select a message and then click **Add Reminder** on the **Follow Up** tab on the toolbar, or right-click on the message and select **Add Reminder** from the popup menu.



The **Add Reminder** window will be displayed.

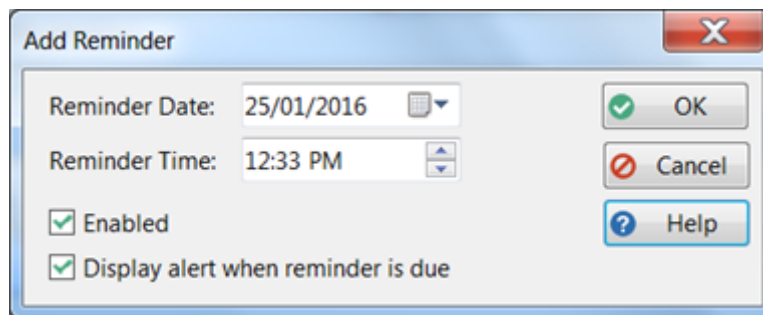

Reminder Date	This is preset to the next day. You can change the date to whatever you want.
Reminder Timer	This is preset to the current time but you can also change this.
Enabled	When checked, the reminder is enabled.
Display alert when reminder is due	When checked, a reminder will be displayed when a reminder is due.

Editing a Reminder

To edit a reminder, select a message and then click **Manage Reminders** on the **Follow Up** tab on the toolbar.



The **Manage Reminders** window will be displayed.

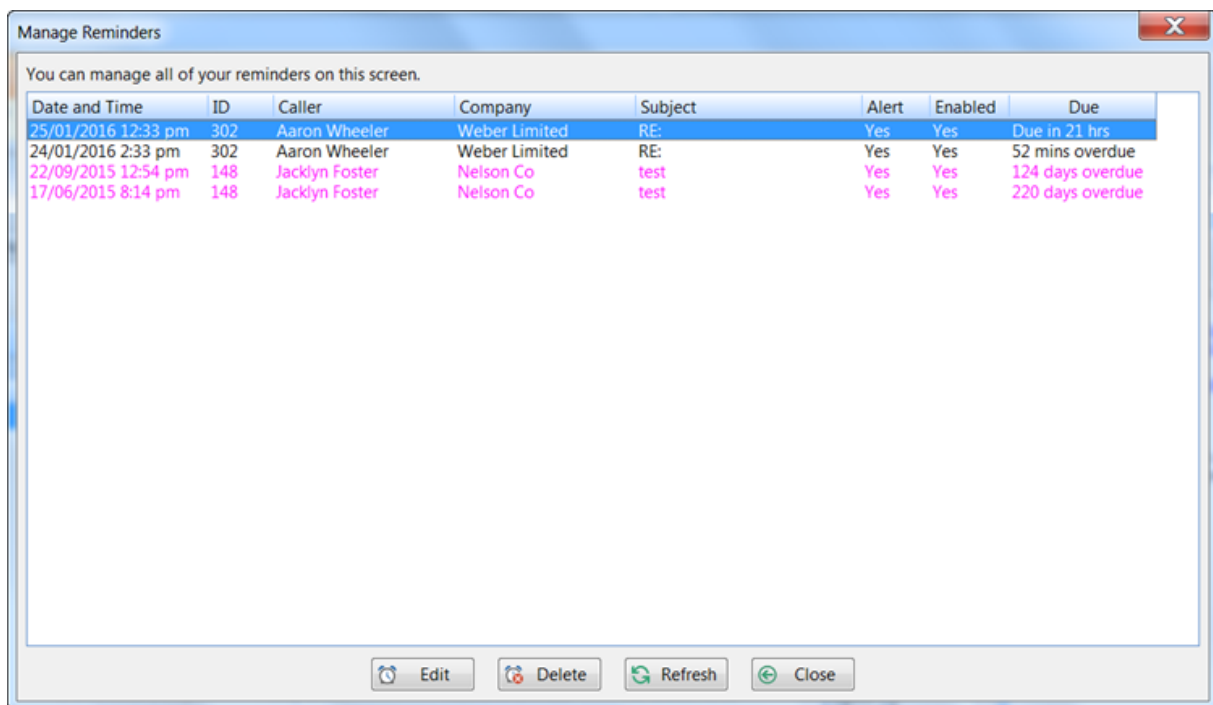

Click the **Edit** button.

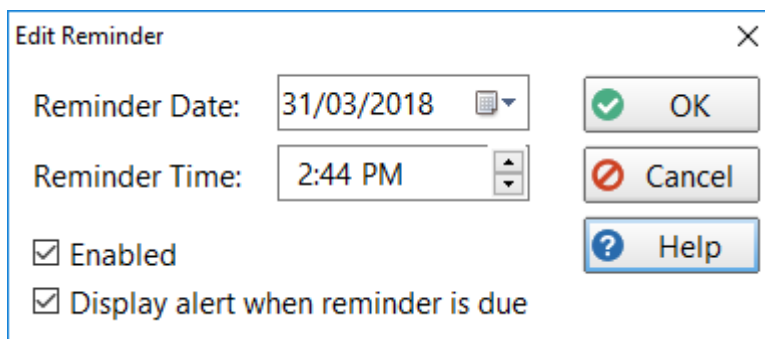

Reminder Date	This is preset to the next day. You can change the date to whatever you want.
Reminder Timer	This is preset to the current time but you can also change this.
Enabled	When checked, the reminder is enabled.
Display alert when reminder is due	When checked, a reminder will be displayed when a reminder is due.

Viewing Due Reminders

The **Reminders** icon on the status bar shows how many due reminders you have. In the example below there are 3 reminders that are due or overdue.

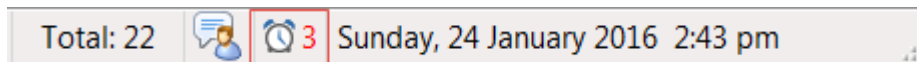

You can view all of your due reminders by clicking on the icon, or by selecting **View Reminders** from the **Follow Up** tab on the toolbar.

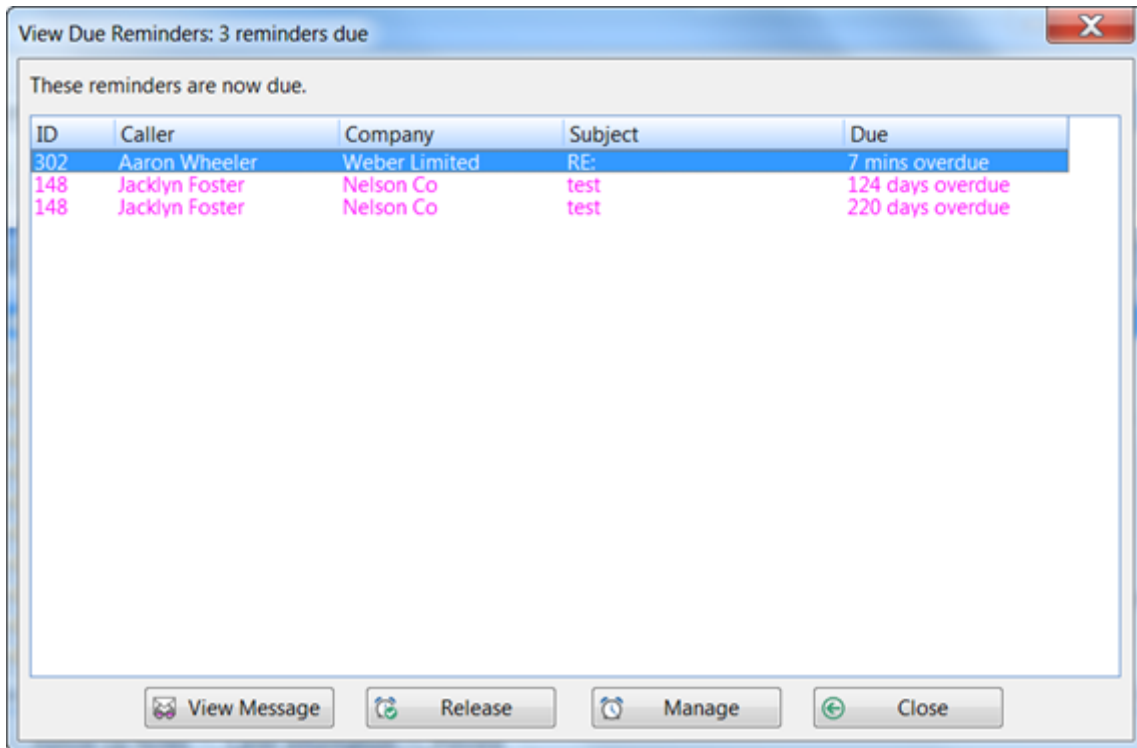

View Message	Click to view the message the reminder is linked to.
Release	Click to dismiss the reminder. Do this when you no longer require the reminder.
Manage	Click to manage all of your reminders.
Close	Click to close this window.

Managing Reminders

If you want to manage your reminders, click the **Manage Reminders** button on the **Follow Ups** tab on the toolbar.

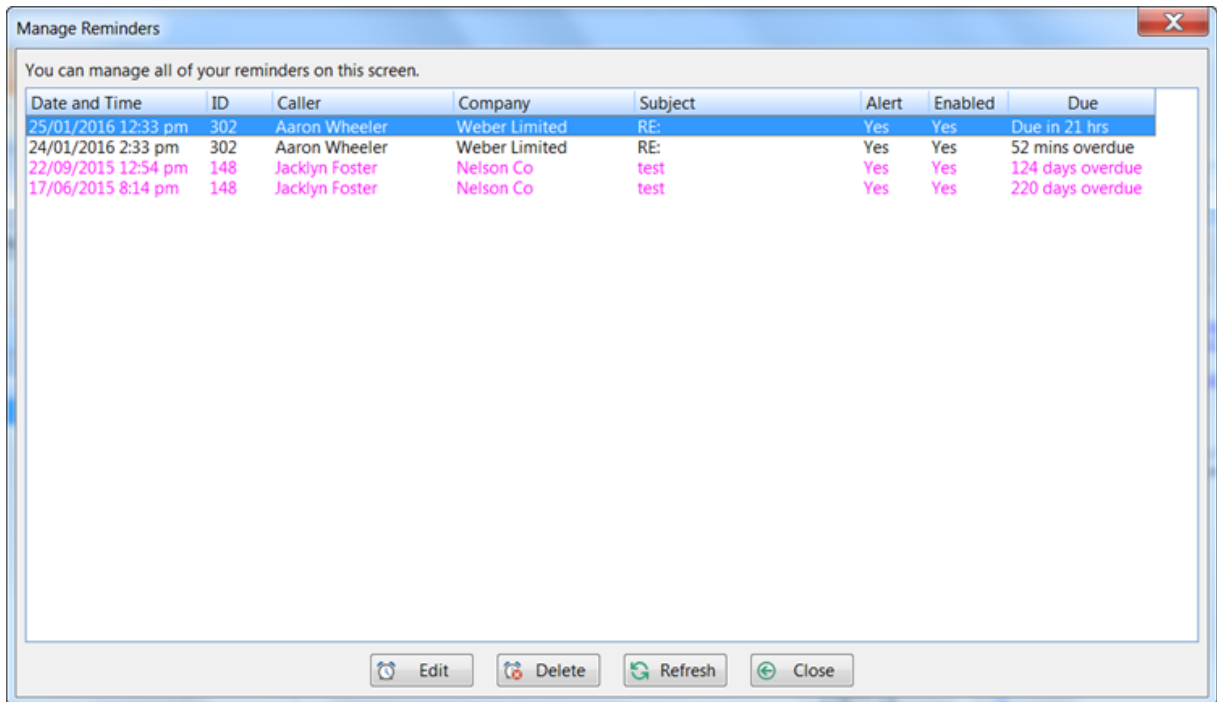

All reminders will be shown: due, overdue and not yet due.

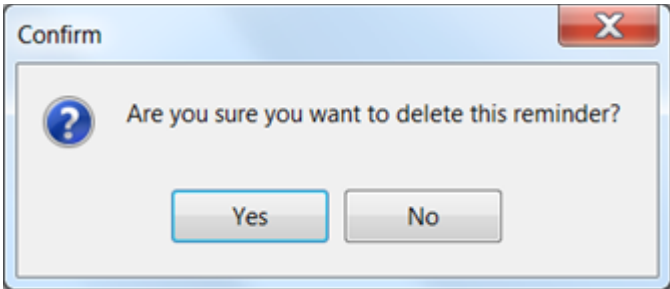
Edit	Click this button so that you can change details of the reminder.
Delete	Click this button to delete the reminder. You will be asked to confirm the deletion. 
Refresh	Click to update the reminder list.
Close	Click to close the window.

Reminder Alerts

You can configure PhonePad to display alerts when reminders are due.

The Reminder icon will flash on the status bar. You can click the icon to view all of your reminders.

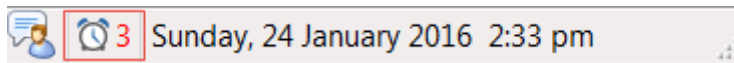

A reminder alert will appear just above the right-side of the Windows taskbar. You can click **View Reminders** to display all of your due and overdue reminders

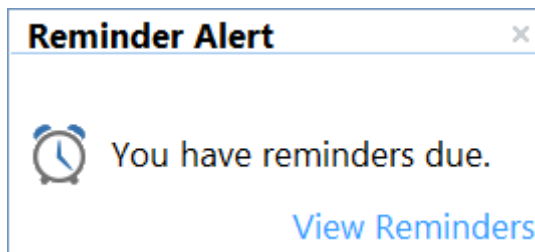

The **View Due Reminders** window will be automatically displayed.

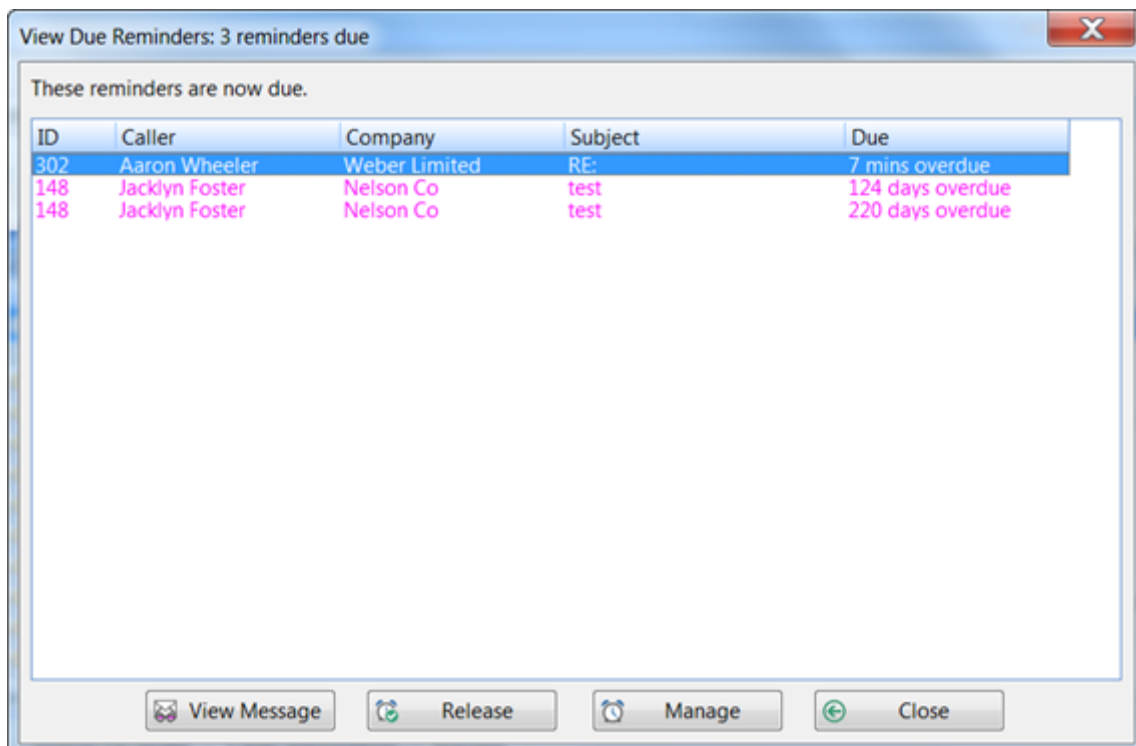

You can configure the reminder alert settings by selecting **Preferences** from the **View** menu and then selecting **Reminders**.

Chapter



7

Caller ID

Caller ID

Caller ID is a handy feature that enables you to see who's calling whenever the phone rings.

PhonePad's Caller ID feature will display a popup window that shows details of the call. Standard Caller ID information shows the phone number and sometimes the caller's name. With PhonePad, if the caller's details are in the Address Book this extra information will also be shown.



CallerID.com

PhonePad incorporates support for Caller ID devices from CallerID.com.

They sell a number of devices which support multiple phone lines. PhonePad is compatible with any of the Ethernet devices (**not** the Serial Port versions).

The bare minimum device is the Basic model with Ethernet connectivity. These are available in 2, 4 and 8 line configurations.



Images are copyright CallerID.com.

How It Works

The CallerID.com devices connect to your phone system and network. The Caller ID data is transmitted over your network to all computers where it is received by PhonePad.

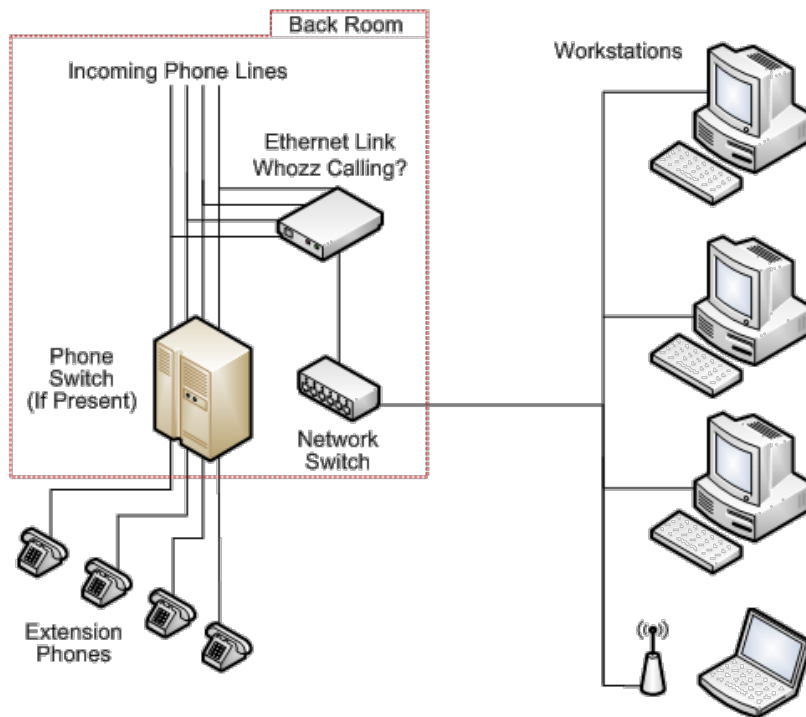
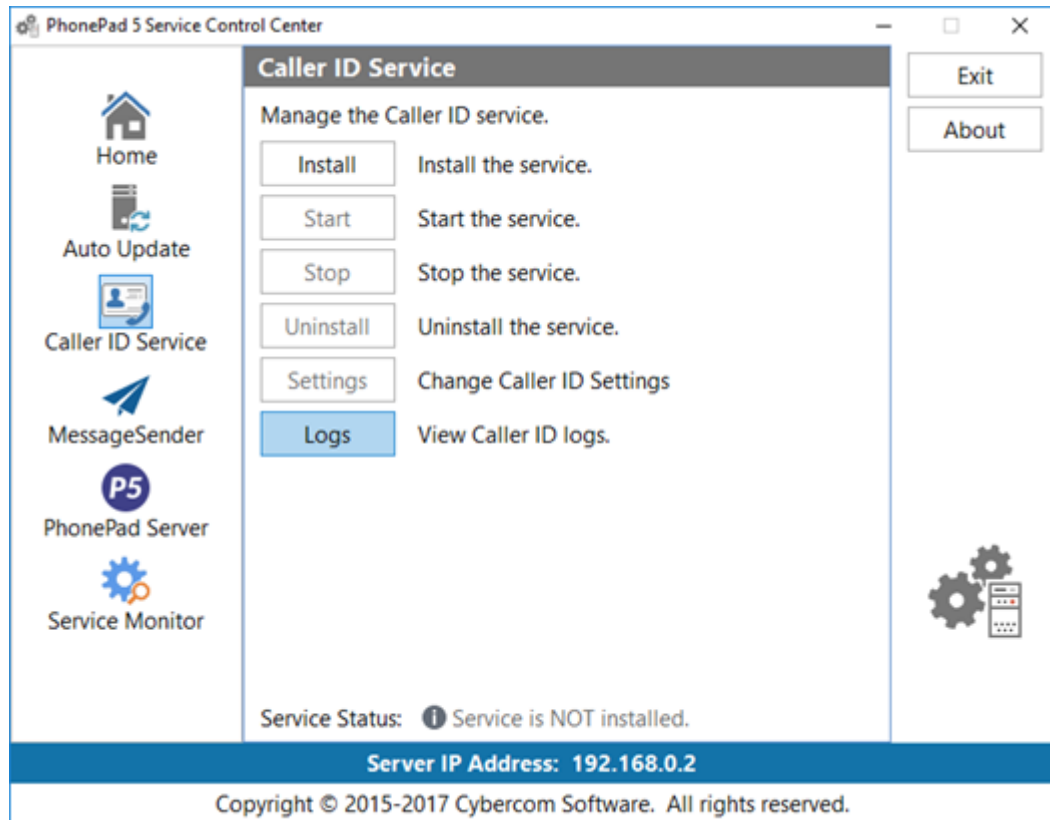

Image: Copyright © callerid.com

The CallerID.com devices work with virtually any phone system.

Installing the Caller ID Service

Before you can use Caller ID you will need to install and start the Caller ID Service using **Control Center** on your Server or Host PC.



1. Run **Control Center**.
2. Select **Caller ID Service**.
3. Click **Install**.
4. Click **Start**.

Configuring CallerID.com

If you have a CallerID.com device on your network you can configure PhonePad to receive the Caller ID data from it by selecting **Caller ID Settings** from the **View**

menu, or by clicking the Caller ID Settings button on the **Settings** toolbar. Select **CallerID.com** from the 3 options, then click **OK**.

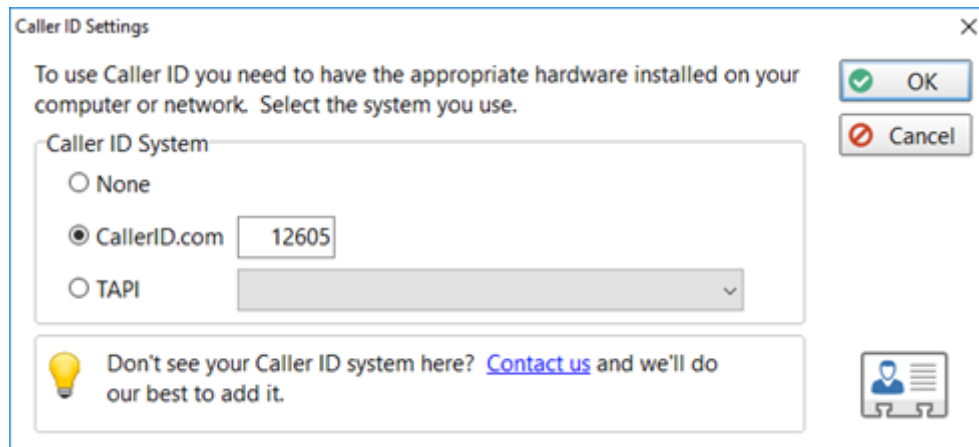

Warning: You can also set the port number but do not change it from the default unless you know for sure that it is different from port **12605**.

 The CallerID.com devices broadcast the Caller ID data on a different port. This data is received by the PhonePad 5 Caller ID Service running on your Server or Host PC. It broadcasts this data to PhonePad 5 on all workstations and logs the data in the PhonePad 5 database. This is how it maintains a history of all calls.

Caller Information

When you receive an incoming call this window will be displayed.



It shows the caller's phone number. PhonePad will also check the Address Book to see if the caller has called before. If they have, their information will be displayed.

If you click the **Take a Message** button PhonePad will open a new message and prefill the caller's details.

Call History

This screen is only available if you have a CallerID.com device installed on your network.

Depending on the version of **CallerID.com** hardware you have connected to your network, PhonePad will maintain a complete history of all incoming calls, or both incoming and outgoing calls for all of your phone lines. This includes answered and unanswered calls.

To access this screen, click on the **Call History** button on the **Follow Up** toolbar, or select **Call History** from the **View** menu.

The screenshot shows a 'Call History' window with two sections: 'Incoming Calls' and 'Outgoing Calls'. Each section contains a table with columns for Line, Date, Duration, Caller, Company, and Phone Number. The 'Incoming Calls' section lists 11 calls, and the 'Outgoing Calls' section lists 3 calls. The window also features 'Print' and 'Close' buttons on the right side and a '24h' icon in the bottom right corner.

Incoming Calls					
Line	Date	Duration	Caller	Company	Phone Number
1	29/09/2017 11:57:00 ...	2 mins 3 secs	Smith, John		800-240-4637
1	29/09/2017 11:28:00 ...	2 mins 3 secs	Smith, John		800-240-4637
1	28/09/2017 4:11:00 PM	2 mins 3 secs	Smith, John		800-240-4637
2	28/09/2017 4:04:00 PM	2 mins 3 secs	Aaron Fisher	Fisher Enterprises	770-263-7111
2	28/09/2017 3:54:00 PM	2 mins 3 secs	Aaron Fisher	Fisher Enterprises	770-263-7111
1	28/09/2017 3:54:00 PM	2 mins 3 secs	Smith, John		800-240-4637
1	28/09/2017 3:53:00 PM	2 mins 3 secs	Smith, John		800-240-4637
1	28/09/2017 3:52:00 PM	2 mins 3 secs	Smith, John		800-240-4637
2	28/09/2017 3:49:00 PM	2 mins 3 secs	Aaron Fisher	Fisher Enterprises	770-263-7111
4	28/09/2017 3:49:00 PM	2 mins 3 secs			No-CallerID
1	28/09/2017 3:48:00 PM	2 mins 3 secs	Smith, John		800-240-4637

Outgoing Calls					
Line	Date	Duration	Caller	Company	Phone Number
4	28/09/2017 4:06:00 PM	2 mins 3 secs			No-CallerID
4	21/09/2017 5:42:00 AM	2 mins 3 secs	Smith, John	Fisher Enterprises	770-263-7111
4	21/09/2017 5:41:00 AM	2 secs	Smith, John	Fisher Enterprises	770-263-7111

Print	Displays the Call History, enabling you to print the list or export it to PDF.
Close	Closes the Call History window.

History List

The **History List** displays a history of all **Incoming Calls**. Depending on the Caller ID hardware you have it may also display all **Outgoing Calls** as well.

Call History
✕

Print
Close

Incoming Calls						
Line	Date	Duration	Caller	Company	Phone Number	
1	29/09/2017 11:57:00 ...	2 mins 3 secs	Smith, John		800-240-4637	
1	29/09/2017 11:28:00 ...	2 mins 3 secs	Smith, John		800-240-4637	
1	28/09/2017 4:11:00 PM	2 mins 3 secs	Smith, John		800-240-4637	
2	28/09/2017 4:04:00 PM	2 mins 3 secs	Aaron Fisher	Fisher Enterprises	770-263-7111	
2	28/09/2017 3:54:00 PM	2 mins 3 secs	Aaron Fisher	Fisher Enterprises	770-263-7111	
1	28/09/2017 3:54:00 PM	2 mins 3 secs	Smith, John		800-240-4637	
1	28/09/2017 3:53:00 PM	2 mins 3 secs	Smith, John		800-240-4637	
1	28/09/2017 3:52:00 PM	2 mins 3 secs	Smith, John		800-240-4637	
2	28/09/2017 3:49:00 PM	2 mins 3 secs	Aaron Fisher	Fisher Enterprises	770-263-7111	
4	28/09/2017 3:49:00 PM	2 mins 3 secs			No-CallerID	
1	28/09/2017 3:48:00 PM	2 mins 3 secs	Smith, John		800-240-4637	

Outgoing Calls						
Line	Date	Duration	Caller	Company	Phone Number	
4	28/09/2017 4:06:00 PM	2 mins 3 secs			No-CallerID	
4	21/09/2017 5:42:00 AM	2 mins 3 secs	Smith, John	Fisher Enterprises	770-263-7111	
4	21/09/2017 5:41:00 AM	2 secs	Smith, John	Fisher Enterprises	770-263-7111	

History List
History Graph

Double-clicking on a call in the Incoming Calls list will open a new incoming phone message with the caller's details prefilled. You can also double-click on a call in the Outgoing Calls list to create a new outgoing message with the caller's details prefilled.

History Graph

The **History Graph** shows a visual representation of all **Incoming Calls** (shown in blue) and **Outgoing Calls** (shown in orange).

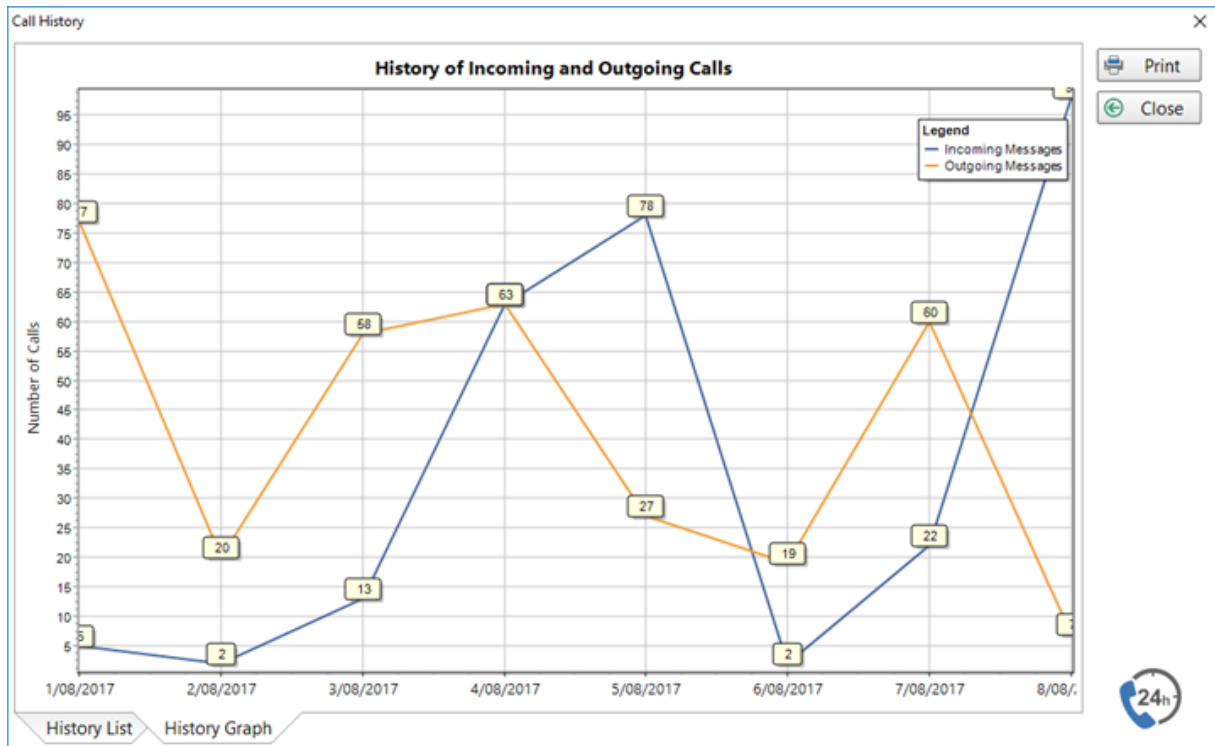

You can scroll through the dates by holding your left mouse button down on the chart and dragging it left or right.

TAPI

PhonePad supports the Microsoft Windows Telephony Application Programming Interface (TAPI). You will require a TAPI-compliant device (eg. a modem) to use this feature.

How It Works

PhonePad doesn't communicate directly with your TAPI devices. Instead it connects through the Microsoft Windows Telephony Application Programming Interface (TAPI) to communicate with any TAPI devices on your workstation or network.

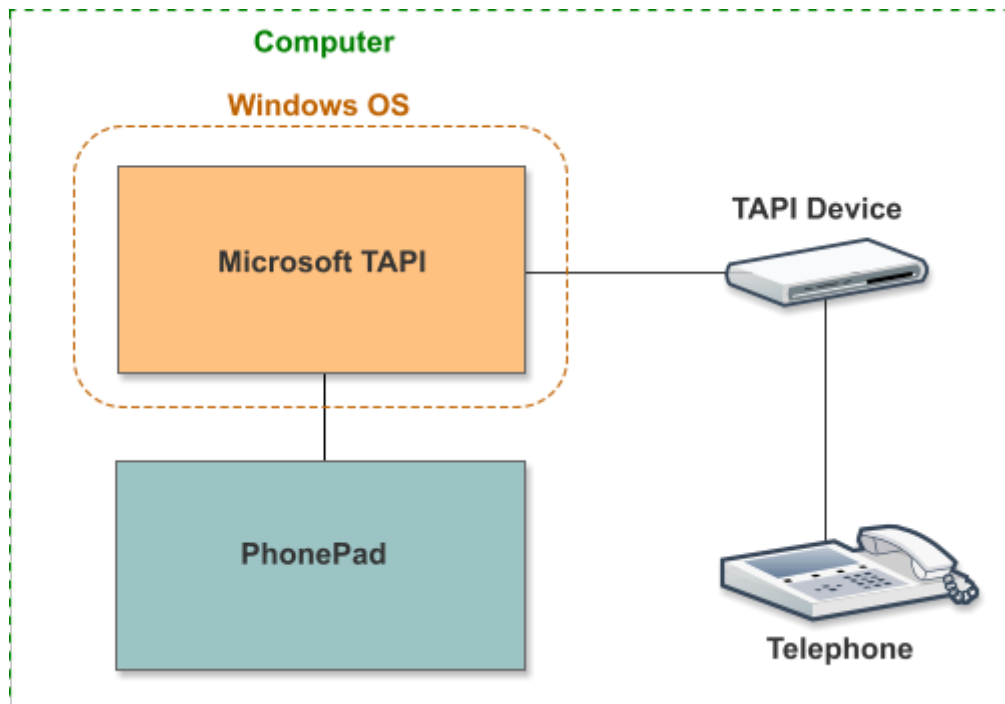

If you have problems with the Caller ID features make sure that your TAPI devices are 100% TAPI compatible and that you have the latest drivers. We have sometimes found that the default drivers installed by Windows don't work.

Configuring TAPI

If you have a TAPI device on your network you can configure PhonePad to receive the Caller ID data from it by selecting **Caller ID Settings** from the **View** menu, or by clicking the Caller ID Settings button on the **Settings** toolbar.

1. Select **TAPI** from the 3 options.
2. Select the TAPI-compliant device you have installed.
3. Click **OK**.

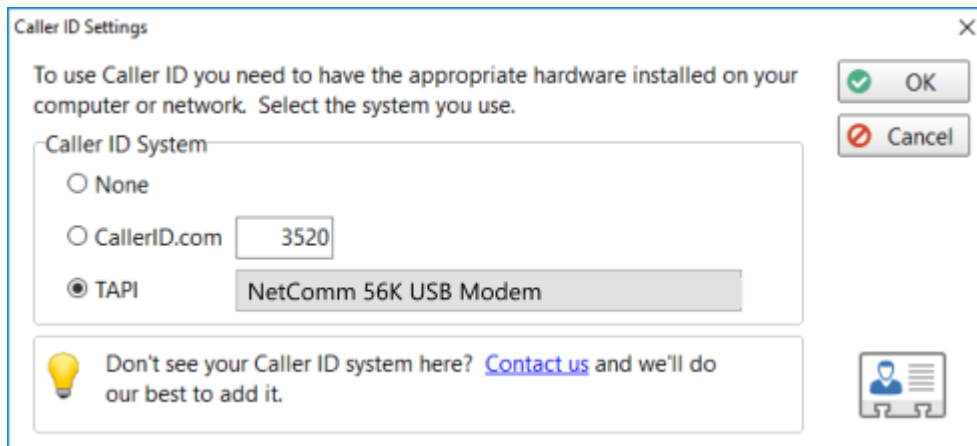

Caller Information

When you receive an incoming call this window will be displayed.



It shows the caller's phone number. PhonePad will also check the Address Book to see if the caller has called before. If they have, their information will be displayed.

If you click the **Take a Message** button PhonePad will open a new message and prefill the caller's details.

Received Calls

PhonePad keeps a history of all calls received, whether you're in the office or not (obviously PhonePad has to be left running). This feature is only available if you have a TAPI device connected.

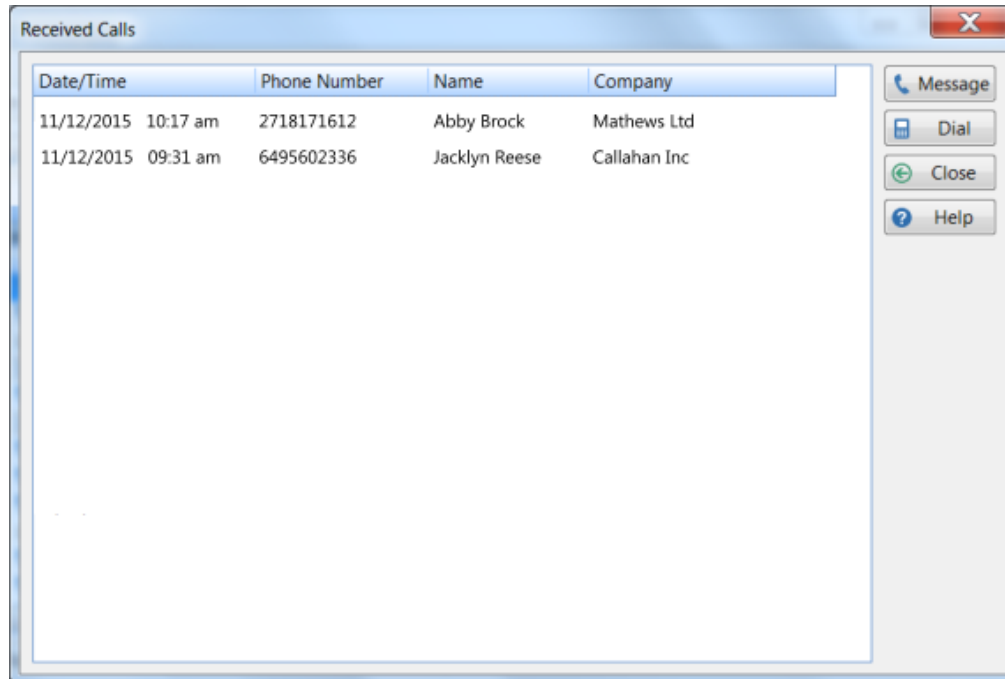

This is a good way to check who has called while you've been out. You can then create phone messages for each of the missed calls by clicking the **Message** button.

You can call the user back using TAPI by clicking the **Dial** button.

Dialling a Number

You can use the TAPI feature of PhonePad to call back callers.

Dialling a Number from the Inbox

Select a phone message in your Inbox and click the **Dial Number** button, or select **Dial Number** from the **File** menu.

All available phone numbers for the caller will be displayed.

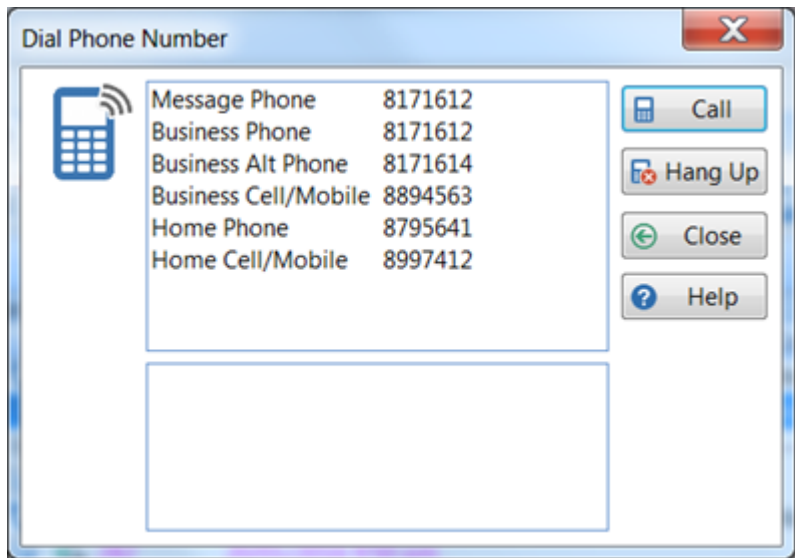

Select a number and then click the **Call** button.

Dialling a Number from Received Calls

From the Received Calls window click the **Dial** button.

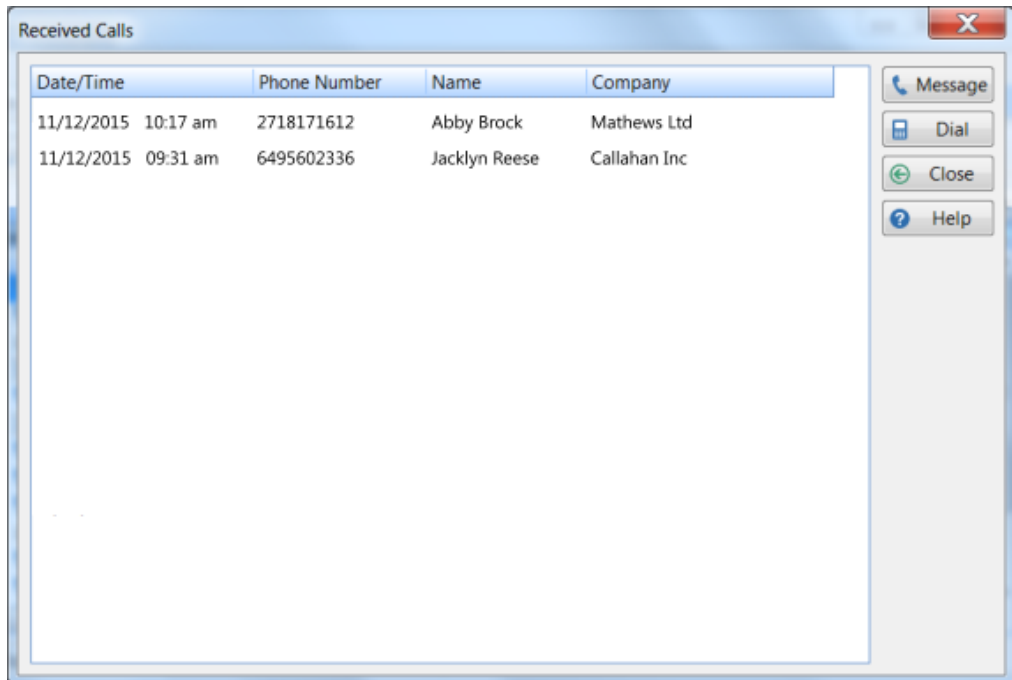

The number of the selected call will be displayed. Click the **Call** button

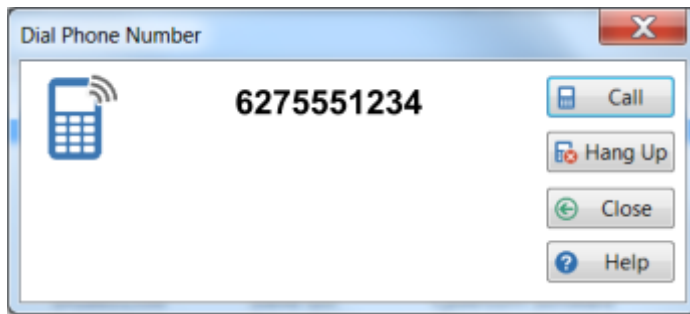

Chapter

8

Global Searching

Global Searching

In addition to the search feature that each message list has, there is a broader, global search option available.

Click the **Search** button on the **Home** toolbar, or select **Search** from the **Tools** menu, or press the **<F3>** key.



The **Global Search** screen allows you to search **all** messages in the database, including those that have been archived, by Caller, Company, Phone Number, Subject and Message Text.

The screenshot shows the PhonePad 5 Global Search interface. The left sidebar has 'Inbox' highlighted. The main window displays a search for 'abby' with results in a table. A 'Return to Inbox' button is highlighted in the top right of the search results area.

ID	Date	Caller	Company	Subject	Phone	Reference	Identification
700	21/04/2018 11:58 am	Abby Delaney	Mcdonald Pty Ltd	Reschedule Appointm...	9884925		
701	21/04/2018 11:58 am	Abby Delaney	Mcdonald Pty Ltd	Reschedule Appointm...	9884925		
3074	4/02/2018 4:05 pm	Abby Mckinney	Stafford Corp	Late Payment.	6614732		
3075	4/02/2018 4:05 pm	Abby Mckinney	Stafford Corp	Late Payment.	6614732		
20392	3/03/2018 12:22 pm	Abby McLaughlin	McMahon and Associ...	Schedule an Appoint...	8153766		
20393	3/03/2018 12:22 pm	Abby McLaughlin	McMahon and Associ...	Schedule an Appoint...	8153766		
21317	28/12/2021 12:48 pm	Abby Drake	Fischer and Sons	Meeting on Friday.	6864659	!	
21318	28/12/2021 12:48 pm	Abby Drake	Fischer and Sons	Meeting on Friday.	6864659	!	

Found 23 messages.

Follow Up Notes | Caller Information | Preview

To: Date: n/a
Time: n/a

From: n/a
Subject: n/a
Message:

Server: 192.168.0.144 5.83.0 Read: 10 Unread: 27 Total: 37 Thursday, 29 February 2024 4:02 pm

Enter your search text in the **Search for** field, next select where you want to search using the **Search in** drop-down list, and finally click the **Search** button.

The **Search for** field remembers your previous searches so you can perform an earlier search by selecting the search text from the drop-down list.

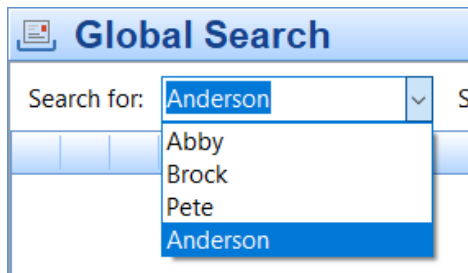

Use the **Search in** drop-down list to select the field to search

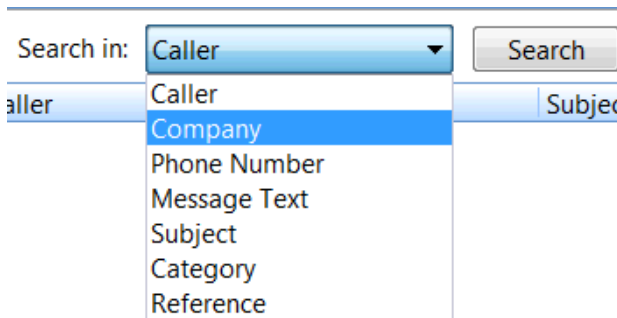

Right-click on the Search message list to show the popup menu.

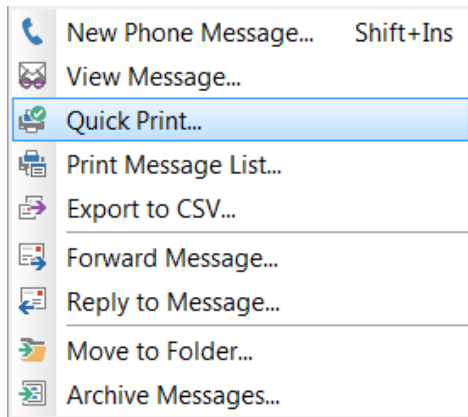

So once you have finished searching, how do you get back to the rest of PhonePad, like the Inbox. Simply select the **Inbox** folder, or click on the **Return to Inbox** link.

This page intentionally left blank.

Chapter

9

Passwords

Passwords

Changing Your PhonePad Password

You can change your PhonePad 5 password at any time by clicking on the **Password** button on the **Settings** tab of the toolbar, or by selecting the **Password** button from the **Tools** menu.



The Password window will appear.

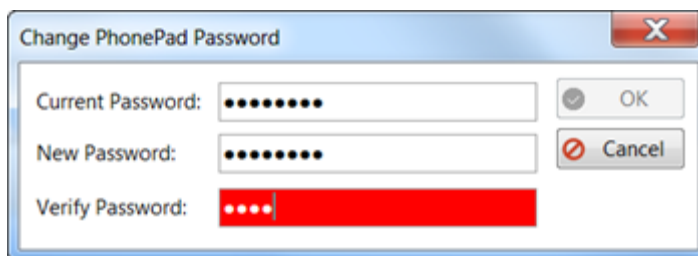

You will not be able to enter a new password until you enter your current password. Once you have entered your current password, enter your new password. You will need to enter this twice to verify that it is correct.

Click **OK** to save the new password.

Chapter

10

Preferences

Preferences

You can customize many parts of PhonePad via user preferences.

To access *Preferences*, click on the **Preferences** button on the **Settings** tab on the toolbar, or select **Preferences** from the **View** menu.



The Preferences window will be displayed.

General

Select the **General** option for *General* settings.

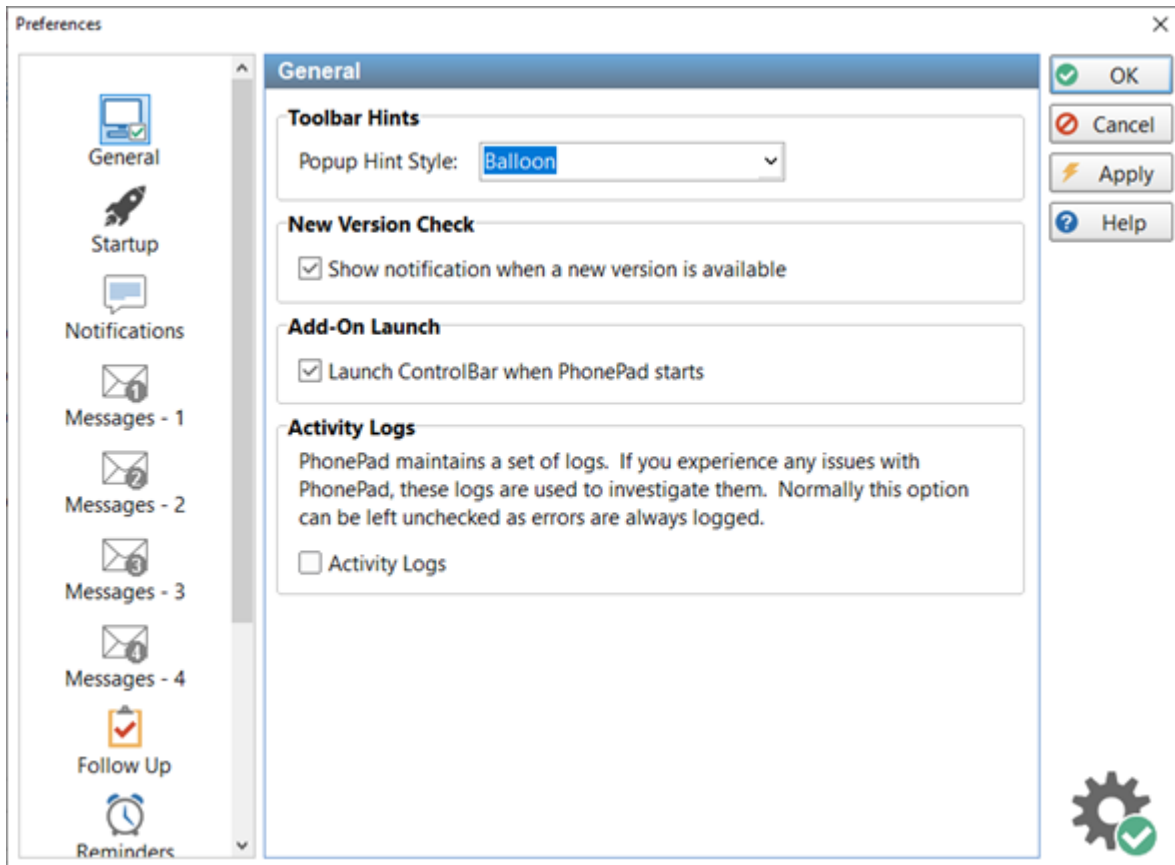

Smart Assistance

- Smart Suggestions
 - Only suggest when clicking the Suggest button
 - Suggest automatically while typing
 - Suggest after typing stops for seconds
- Detect urgency automatically
- Suggest Follow Up Dates

Toolbar Hints	
Popup Hint Style	This setting affects the appearance of the popup hints displayed when you hover the mouse over toolbar buttons.
New Version Check	
Show notificatio	Displays a popup message when a new version of PhonePad 5 is available for download. This option only appears for administrators.

n when a new version is available	
Add-On Launch	
Launch Control Bar When PhonePad Starts	When checked, the Control Bar will start when PhonePad starts.
Launch ToDo List When PhonePad Starts	When checked, the ToDo List will start when PhonePad starts.
Activity Logs	
Activity Logs	When checked, PhonePad will log lots of different processes. To improve system performance this is normally left unchecked. However, it may need to be checked for support purposes. Errors are always logged regardless of this setting.
Smart Assistance	
Smart Suggestions	When enabled, Smart Suggestions will be active.
Only suggest when clicking the Suggest button	When selected, suggestions are invoked when the Suggest button is clicked.

Suggestion automatically while typing	When selected, suggestions will be done automatically. No need to click the Suggest button.
Suggest after typing stops for x seconds	Determines how long to wait before automatically making suggestions.
Suggest Follow Up Dates	Attempts to calculate when a follow update date should be set.

Startup

Select the **Startup** option for PhonePad startup settings.

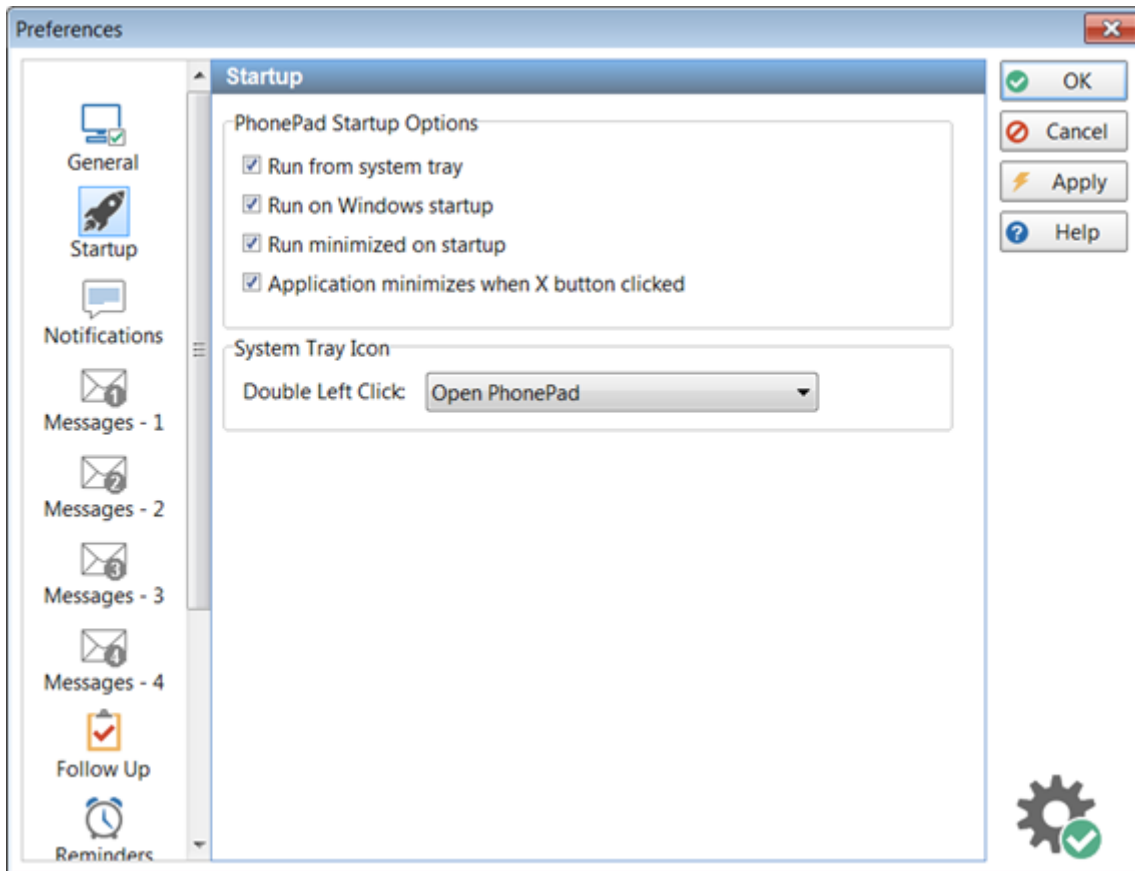

PhonePad Startup Options	
Run from system tray	When checked, PhonePad will run from the system tray.
Run on Windows startup	When checked, PhonePad will start automatically when Windows starts.
Run minimized on startup	When checked, PhonePad will minimize when it starts.
Application minimizes when X button clicked	When checked, PhonePad will minimize instead of closing when the X (close button) is clicked.
System Tray Icon	
Double Left Click	You can specify what happens when a user double-clicks on the PhonePad icon in the system tray:

	<ul style="list-style-type: none"> • Open PhonePad • Create a New Phone Message • Create a New Outgoing Message • Create a New Text Message • Display Address Book
--	---

Overridden Settings

Your PhonePad system administrator can override these settings using **System Rules**. If this has been done then you will be unable to change any of these settings.

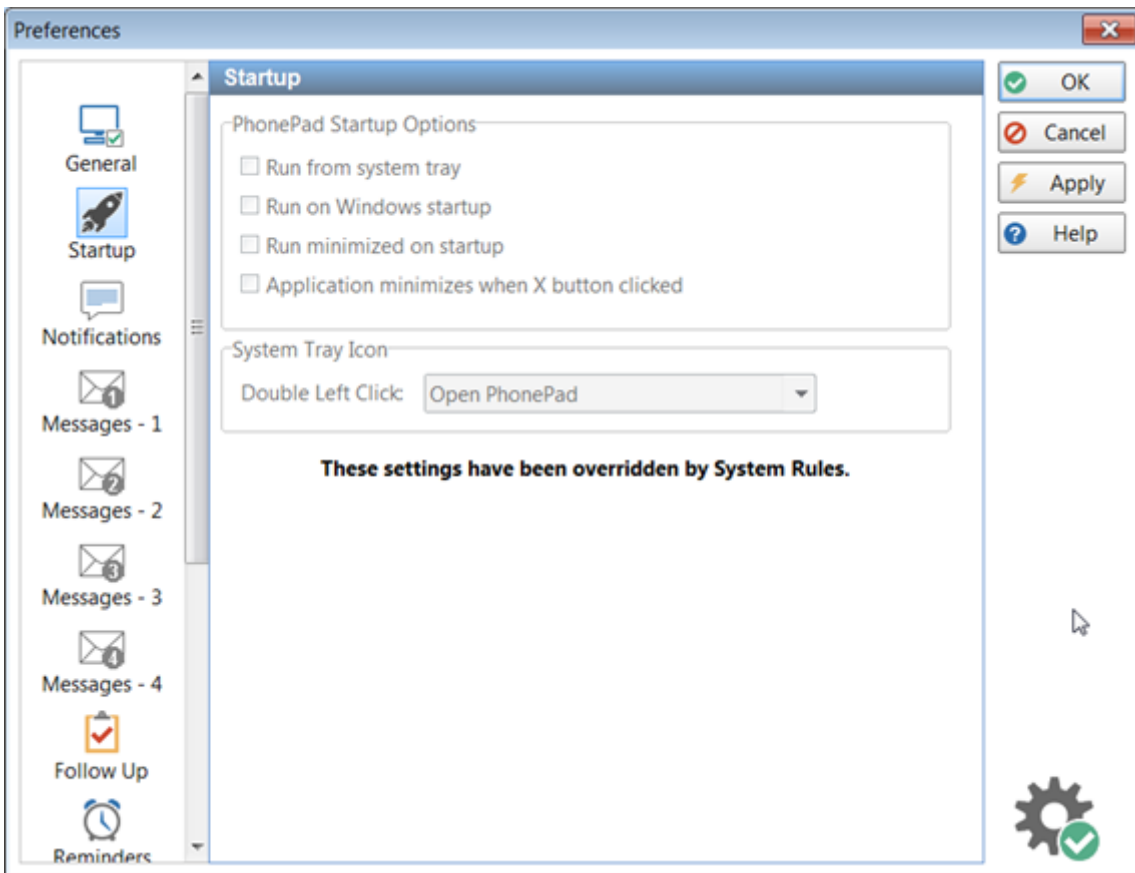

Notifications

The **Message Notification** options can alert you whenever a new message arrives in your Inbox.

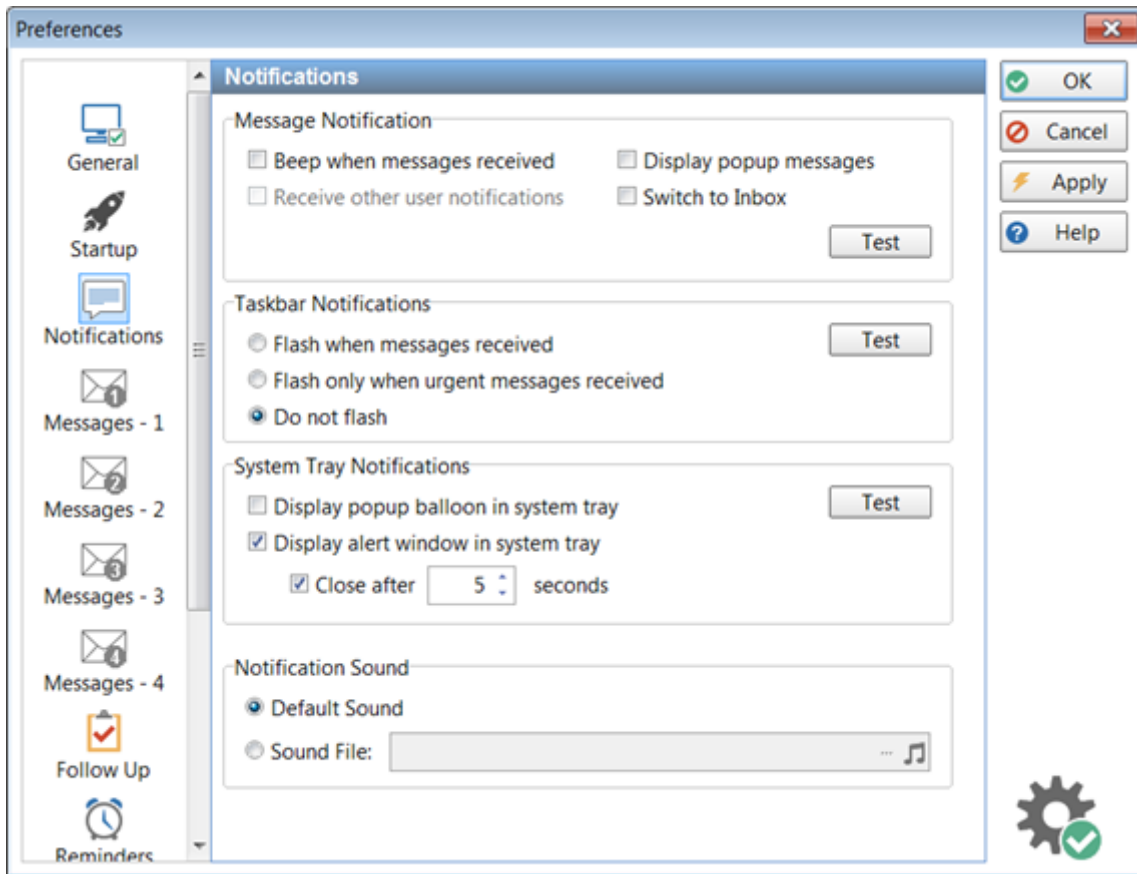

Message Notification	
Beep when messages received	A standard Windows beep will sound whenever a new message is received in your Inbox. If you select a Notification Sound then that sound will be heard.
Display popup messages	Displays a popup message when a new message is received in your Inbox.

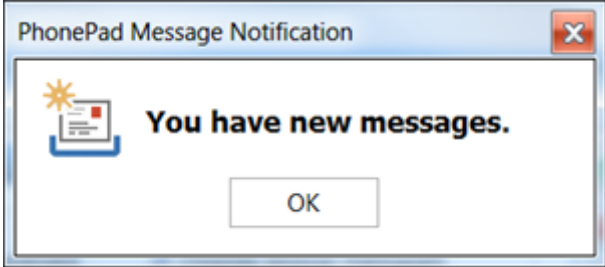
	
<p>Receive other user notifications</p>	<p>This option is only enabled if you have access to other user's folders. When checked, you can receive new message notifications for other users. However, you have to have the user selected in the user list to receive their new message notifications. This means that you can only receive notifications for one user at a time. To receive notifications for all users you will need to use the soon-to-be-released MessageAlert application (which will be included in an update).</p>
<p>Switch to Inbox</p>	<p>When checked, PhonePad automatically switches to the Inbox when new messages are received.</p>
<p>Test</p>	<p>Click the Test button to test these settings.</p>
<p>Taskbar Notifications</p>	
<p>Flash when messages received</p>	<p>PhonePad's icon on the taskbar flashes when a new message is received in your Inbox.</p>
<p>Flash only when urgent messages received</p>	<p>PhonePad's icon on the taskbar flashes only when a new urgent message is received in your Inbox.</p>
<p>Do not flash</p>	<p>Flashing is disabled.</p>
<p>Test</p>	<p>Click the Test button to test these settings.</p>
<p>System Tray Notifications</p>	
<p>Display popup</p>	<p>When checked, a popup balloon will be displayed in the system tray.</p>

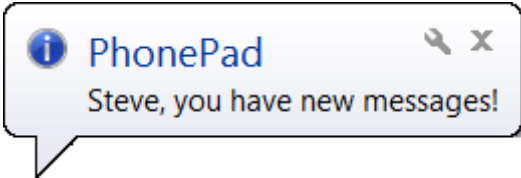
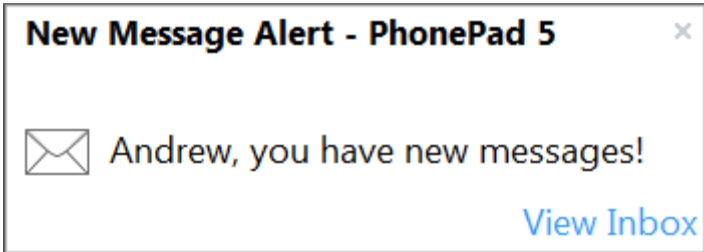
balloon in system tray	
Display alert window in system tray	<p>When checked, an alert window will be displayed in the system tray whenever new messages are received.</p> 
Close after x seconds	<p>When checked, the New Message Alert window will automatically close after the specified number of seconds. The minimum is 5 seconds and the maximum is 30 seconds. The default is 5 seconds.</p> <p>If unchecked, the message alert window won't close until you close it.</p>
Test	Click the Test button to test these settings.
Notification Sound	
Default sound	When selected, plays the default Windows beep when a new message is received.
Sound file	<p>Instead of using the default Windows beep for alerting you about new messages, you can play a WAV file. Click on the button and select the WAV file to play. 30 sounds are included with PhonePad but you can also add your own. It's best to using a sound file that has a short duration.</p> <p>Click the sound button to preview the sound.</p>

Messages - 1

Messages-1 contains the first of a number of message settings.

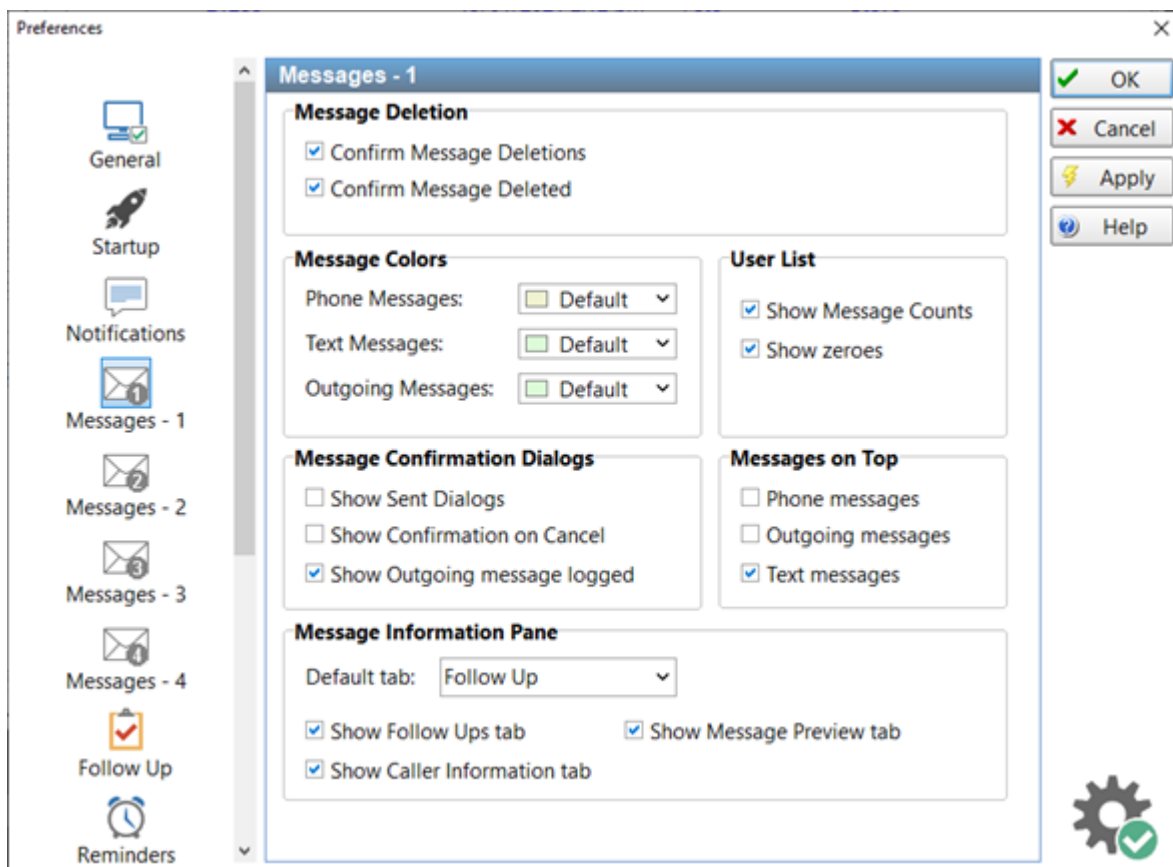

Message Deletion	
Confirm Message Deletions	When checked, you will be prompted to confirm any message deletions.
Confirm Message Deleted	When checked, a message will be displayed when a message is deleted.
Message Colors	
Phone Messages	Set the color of the Phone message form.

Text Messages	Set the color of the Text message form.
Outgoing Messages	Set the color of the Outgoing message form.
Message Confirmation Dialogs	
Show Sent Dialogs	When checked, a message will be displayed when a message has been sent.
Show Confirmation on Cancel	When checked, you will be prompted to confirm a message cancellation.
User List	
Show Message Counts	When checked, the User List will display message counts for Unread Messages and Uncompleted Follow Ups.
Show Zeroes	When checked, and <i>Show Message Counts</i> is checked as well, zeroes will be displayed where the user has no Unread Messages and/or Uncompleted Follow Ups. If unchecked, blank spaces will be shown instead of zeroes.
Message Information Pane	
Default Tab	Specifies which tab should be selected by default when PhonePad starts.
Show Follow Ups Tab	When checked, the Follow Ups tab will be displayed in the Message Information Pane located below the Inbox messages list.
Show Caller Information Tab	When checked, the Caller Information tab will be displayed in the Message Information Pane located below the Inbox messages list.
Show Message Preview Tab	When checked, the Message Preview tab will be displayed in the Message Information Pane located below the Inbox messages list.

Messages - 2

Messages-2 contains additional message settings.

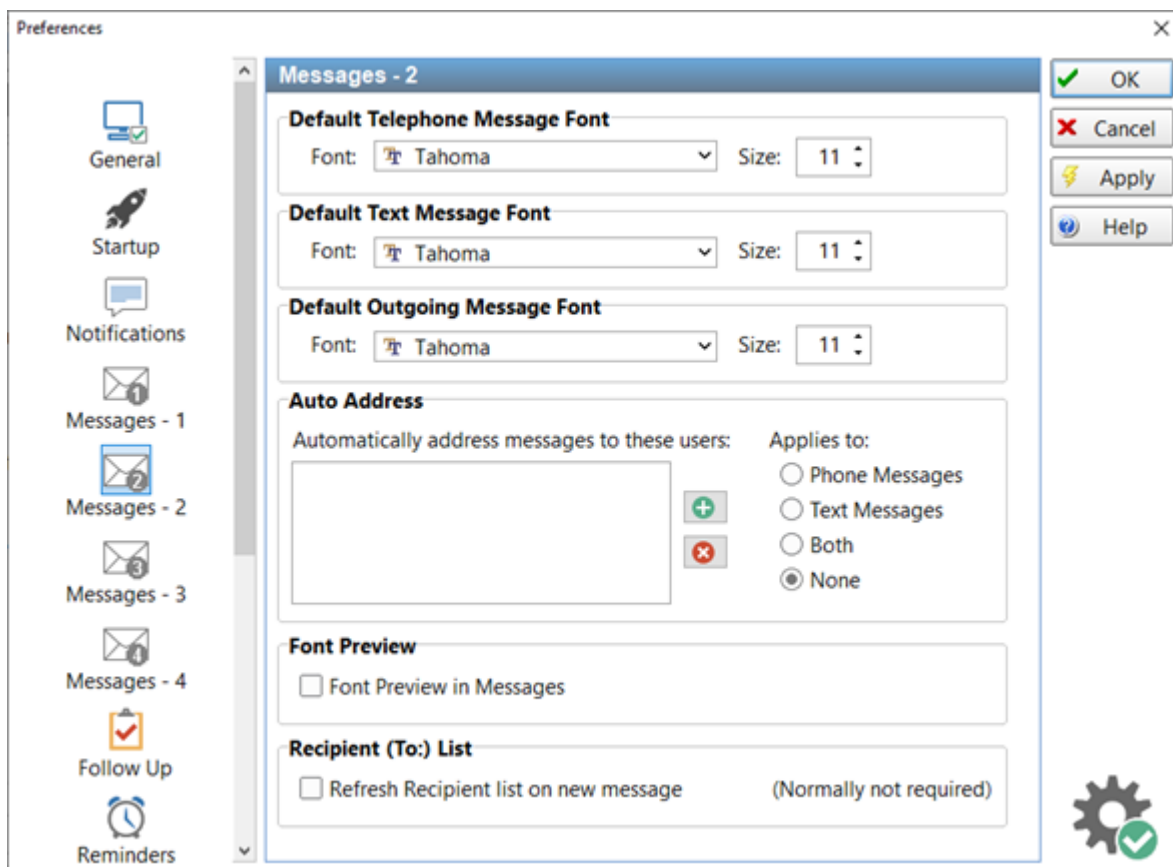

Default Telephone Message Font	
Font	Specifies the default font to be used for message text of new Phone messages.
Size	Specifies the default font size to be used for message text of new Phone messages.
Default Text Message Font	
Font	Specifies the default font to be used for message text of new Text messages.
Size	Specifies the default font size to be used for message text of new Text messages.

Default Ongoing Message Font	
Font	Specifies the default font to be used for message text of new Outgoing messages.
Size	Specifies the default font size to be used for message text of new Outgoing messages.
Auto Address	
Automatically address messages to these users	<p>The auto address feature allows you to automatically add recipients to new messages. If you tend to send messages to the same recipients all the time, this option can save you a bit of time by adding the recipients for you. Use the plus and minus buttons to add or remove users to/from the list.</p> <p>Select the type of messages this applies to.</p>
Font Preview	
Font Preview in Messages	When checked, the font drop-down list will display a preview of the font in a small window in Phone, Outgoing and Text messages.
Recipient (To:) List	
Refresh Recipient List on New Message	If you have added some new users and they are not appearing in the To list then you can use this option to force them to appear. You won't normally need to do this as the recipient list is usually updated automatically.

Messages - 3

Messages-3 contains additional message settings.

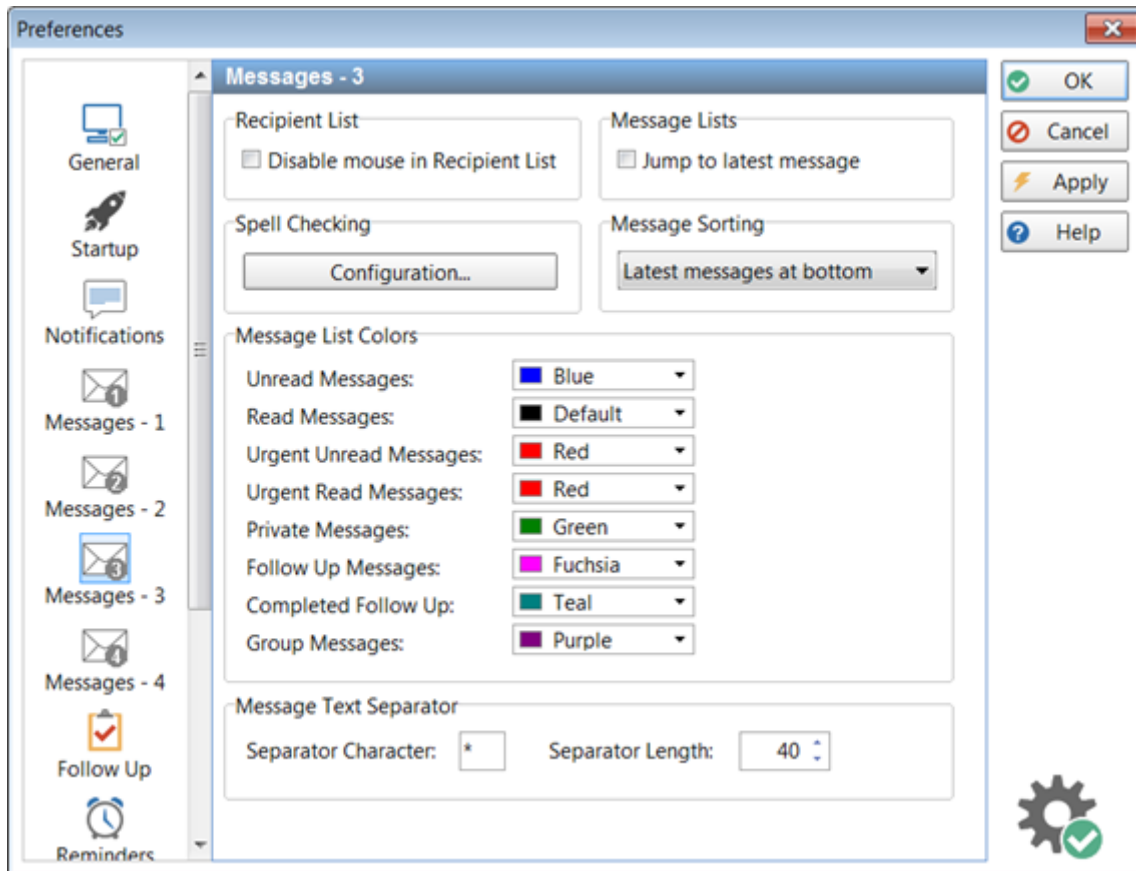

Recipient List

Disable mouse in Recipient List

When checked, the mouse cannot be used to select names in the Recipient List in telephone messages. This option is generally used to prevent accidental selection of names when using the keyboard for recipient selection.

Message Lists

Select latest message

When checked, the Inbox message list will always scroll to the latest message when new messages are received.

Spell Checking

Configuration

Allows you to specify the settings for Spell Checking.

Message Sorting

Message Sorting	This option allows you to specify the sort order of all message lists in PhonePad, including the Follow Up Notes list. You can set this option to either display the newest messages at the bottom of the list or the top.
Message List Colors	
Unread Messages	Defines the text color to be used for Unread Messages in message lists.
Read Messages	Defines the text color to be used for Read Messages in message lists.
Urgent Unread Messages	Defines the text color to be used for Unread Urgent Messages in message lists.
Urgent Read Messages	Defines the text color to be used for Read Urgent Messages in message lists.
Private Messages	Defines the text color to be used for Private Messages in message lists. Affects only unread messages. Read messages will appear in the Read Messages color.
Follow Up Messages	Defines the text color to be used for Follow Up Messages in message lists.
Completed Follow Up	Defines the text color to be used for Completed Follow Ups in message lists.
Group Messages	Defines the text color to be used for Group Messages in message lists. Affects only unread messages. Read messages will appear in the Read Messages color.

Messages - 4

Messages-4 contains additional message settings.

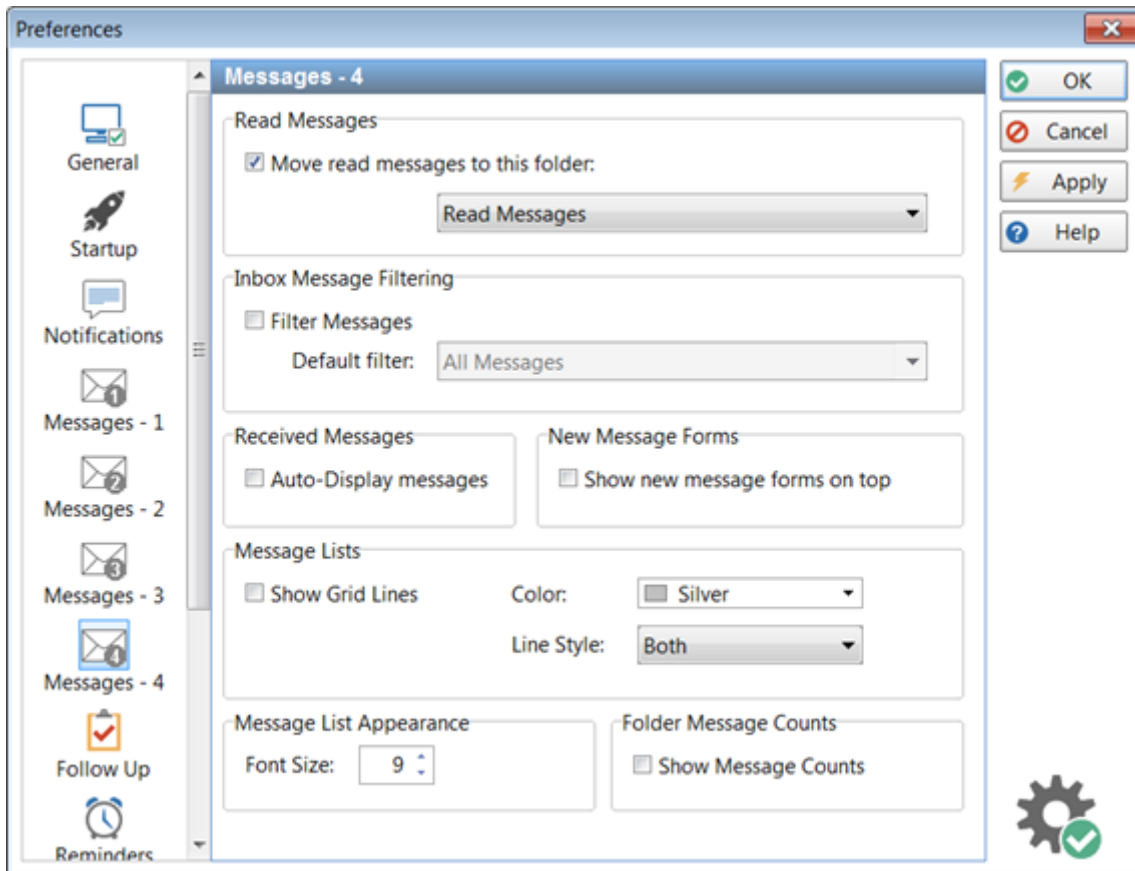

Read Messages	
Move read messages to this folder	When checked, when you finish reading a message it will automatically be moved to the folder you specify.
Inbox Message Filtering	
Filter Messages	When checked, the Inbox will apply the Default Filter when PhonePad starts.
Received Messages	
Auto-Display Messages	When checked, new messages received will automatically be displayed as they are received.
New Message Forms	
Show new message	When checked, new messages will be displayed on top of the main window.

forms on top	
Message Lists	
Show Grid Lines	When checked, grid lines will be displayed in each message list, based on the settings below.
Color	Specifies the color of the lines.
Line Style	Specifies the lines to be displayed: Horizontal, Vertical, or Both.
Message List Appearance	
Font Size	Allows you to specify the font size used in all message lists.

Messages - 5

Messages-5 contains additional message settings.

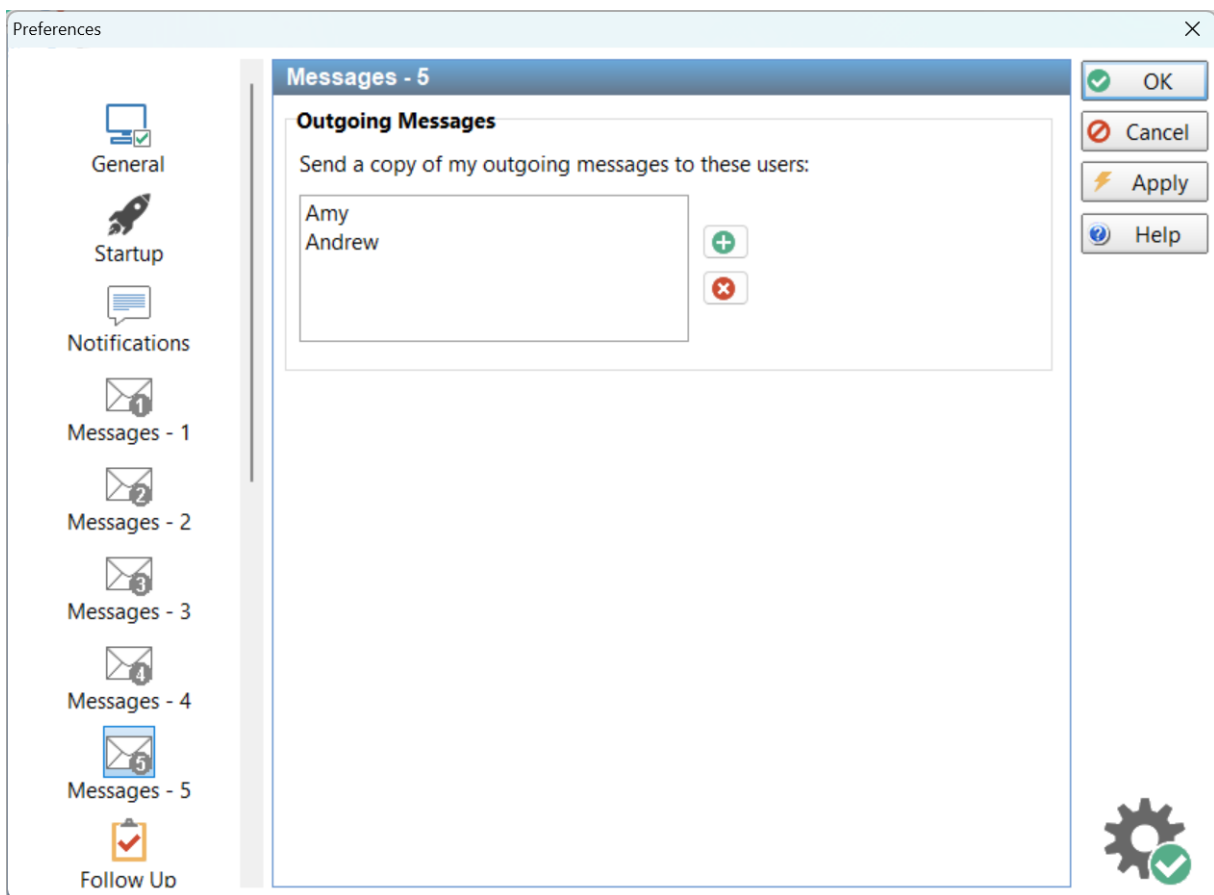

Outgoing Messages

Users added to this list will receive copies of any outgoing messages you log.

Follow Up

The **Follow Up** page contains options for customizing message Follow Up settings.

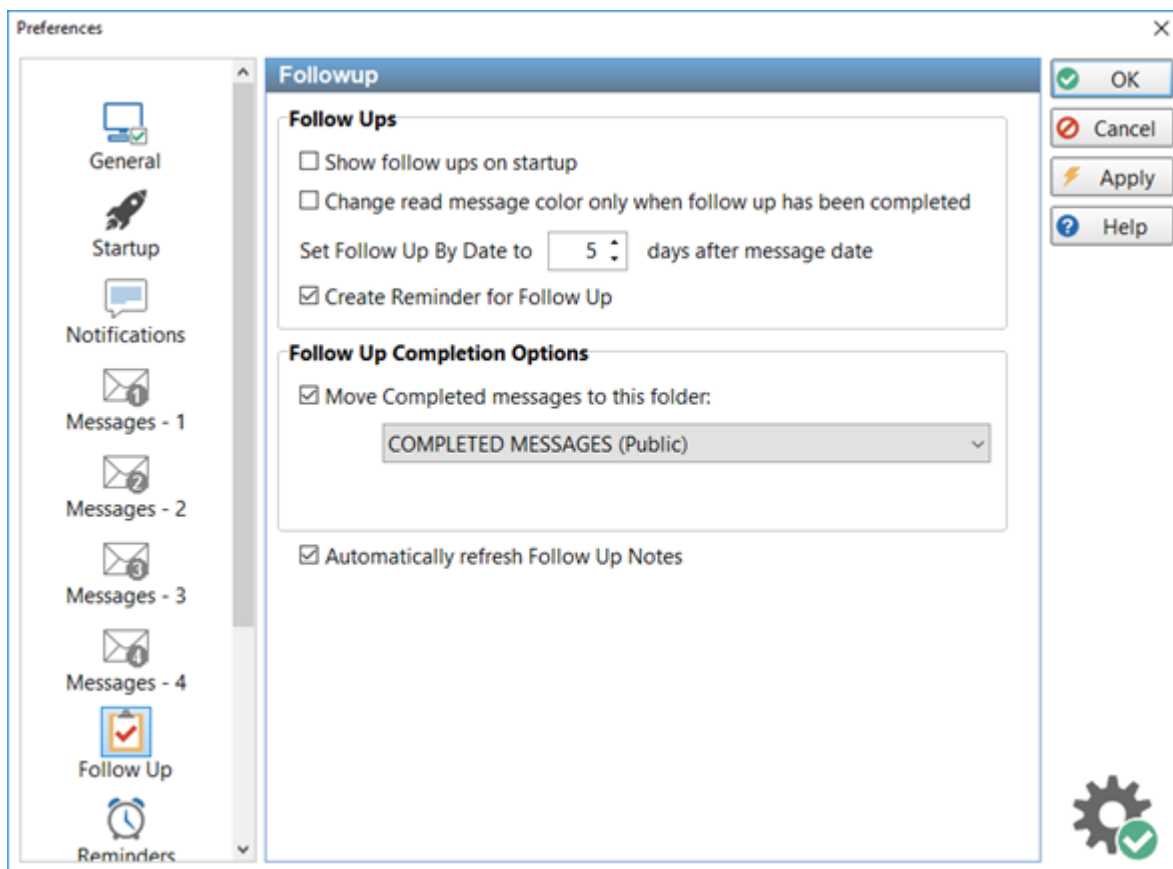

Follow Ups	
Show follow ups on startup	When checked, the Inbox will be filtered to show messages that require follow up. This overrides the Inbox Message Filtering option.
Change read message	Normally, the color of a message will change in the Inbox message list when the message has been read. If this option is

color when follow up has been completed	checked, the color will only change when the message has been followed up.
Set Follow Up By Date to x days after message date	Sets the default Follow Up By Date to the specified number of days after the current date, when the Follow Up By check box is checked.
Create Reminder for Follow Up	When checked, a reminder will be automatically created when you mark a message for follow up. If you then unmark the message for follow up, or complete the follow up, the reminder will be automatically deleted.
Follow Up Completion Options	
Move Completed messages to this folder	When checked, when a Follow Up is marked as Completed it will be moved to the specified folder.
Automatically refresh Follow Up Notes	When checked, the Follow Up Notes will be automatically refreshed. Otherwise, you may occasionally need to refresh it manually.

Reminders

Reminders are an important part of PhonePad. You can customize some of their behavior here.

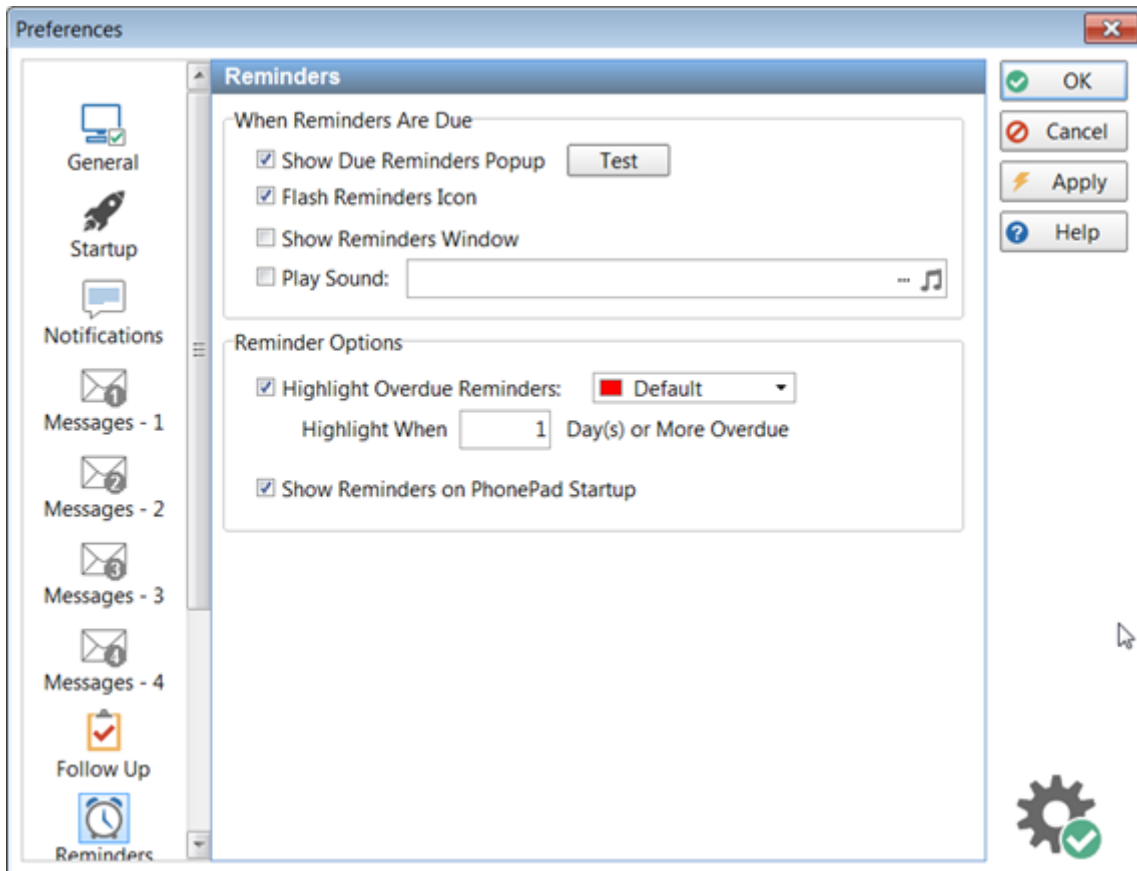

When Reminders Are Due	
<p>Show Due Reminders Popup</p>	<p>When checked, a reminder popup will be displayed above the system tray.</p> <div style="border: 1px solid #ccc; padding: 10px; margin: 10px 0;"> <p>Reminder Alert ×</p> <p> You have reminders due.</p> <p style="text-align: right;">View Reminders</p> </div> <p>Use the Test button to test this setting.</p>
<p>Flash Reminders Icon</p>	<p>When checked, the reminders icon on the status bar will flash.</p>

Show Reminders Window	When checked, the reminders window will be displayed when a reminder is due.
Play Sound	When checked, the selected sound will play when a reminder is due.
Reminder Options	
Highlight Overdue Reminders	When checked, overdue reminders will be highlighted in the reminders window using the selected color.
Highlight When x Days(s) or More Overdue	When checked, reminders will be highlighted when they are the specified number of days overdue.
Show Reminders on PhonePad Startup	When checked, due reminders will be displayed when PhonePad starts.

Address Book

These settings apply to the PhonePad Address Book.

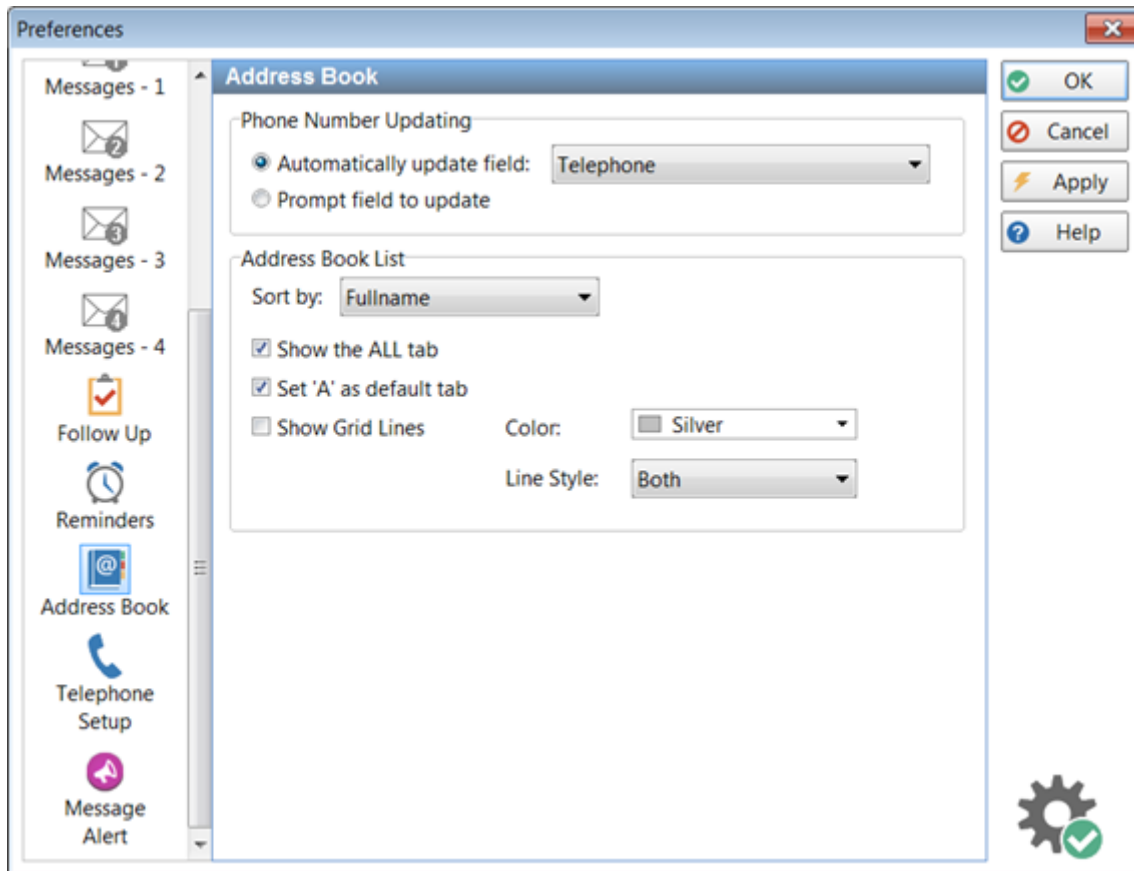

Phone Number Updating

Automatically update field

When selected, automatically updates the specified field in the Address Book whenever the phone field is changed in a phone message. You can set it to update the Telephone, Alt. Phone, Fax, or Cell/Mobile field.

Prompt field to update

When selected, you will be prompted for the appropriate field to update in the Address Book.

Address Book List

Sort by

Use this option to set how you want the Address Book window sorted. Select from Firstname, Lastname, Fullname or Company.

Show the ALL tab

When checked, the ALL tab will be displayed, allowing you to view all Address Book entries at once. Uncheck this option to improve performance if you have a large Address Book.

Show Lines	When checked, the Address Book list will have horizontal and vertical lines making it easier to view.
Set 'A' as default tab	When checked, the 'A' tab will be displayed when you open the Address Book instead of the 'ALL' tab. The Address Book will load the entries faster.

Telephone Setup

This page relates to Caller ID functionality within PhonePad 5.

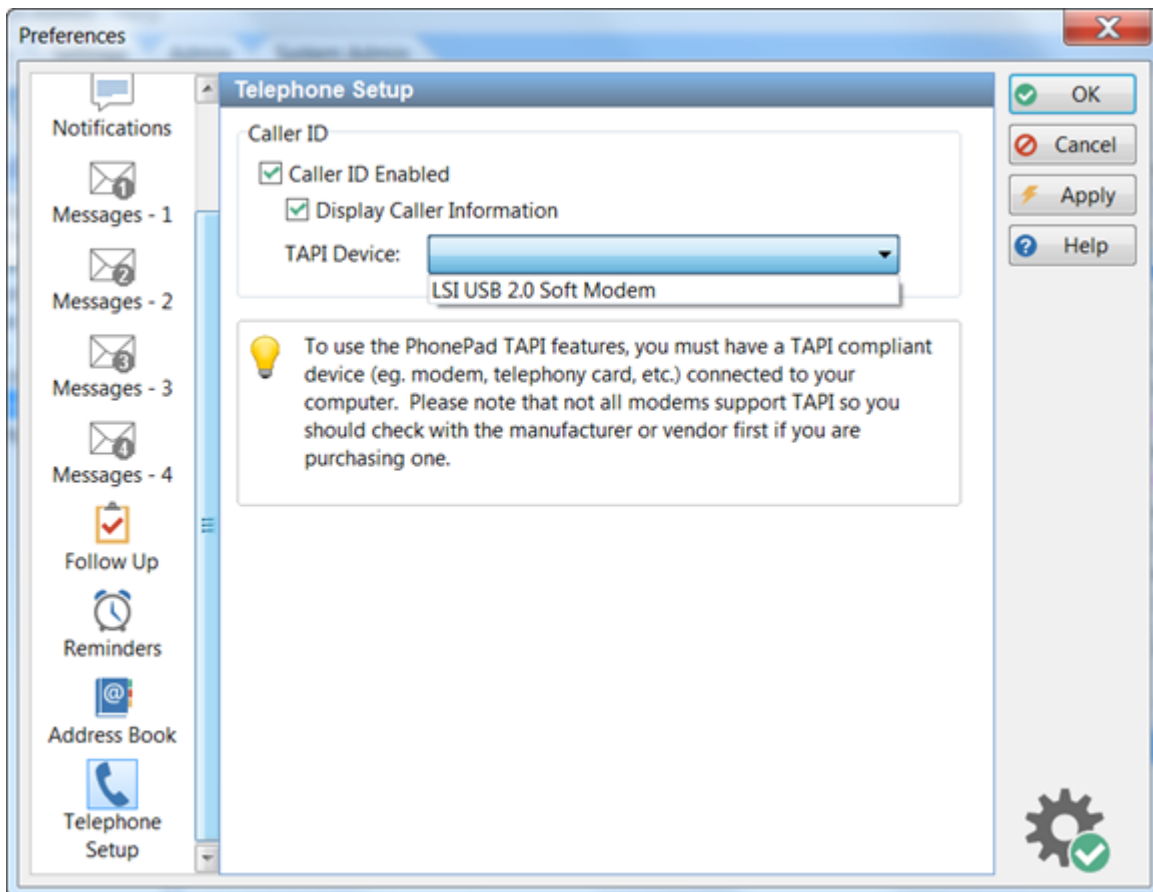

Caller ID	
Caller ID Enabled	When checked, the Caller ID feature will be enabled.

Display Caller Information	When checked, the Caller Information window will be displayed when a phone call is received.
TAPI Device	When checked, the reminder is enabled.

Short Messaging

Short messaging gives you the ability to send quick, ad-hoc messages to cell phones and mobile devices that have an Internet connection. Currently you can send SMS messages and also messages via Pushover (which are free for up to 7500 messages per month).

Please note: This is different from the Automatic Message Forwarding feature.

Pushover Messages

There are optional default settings you can set for Pushover messages.

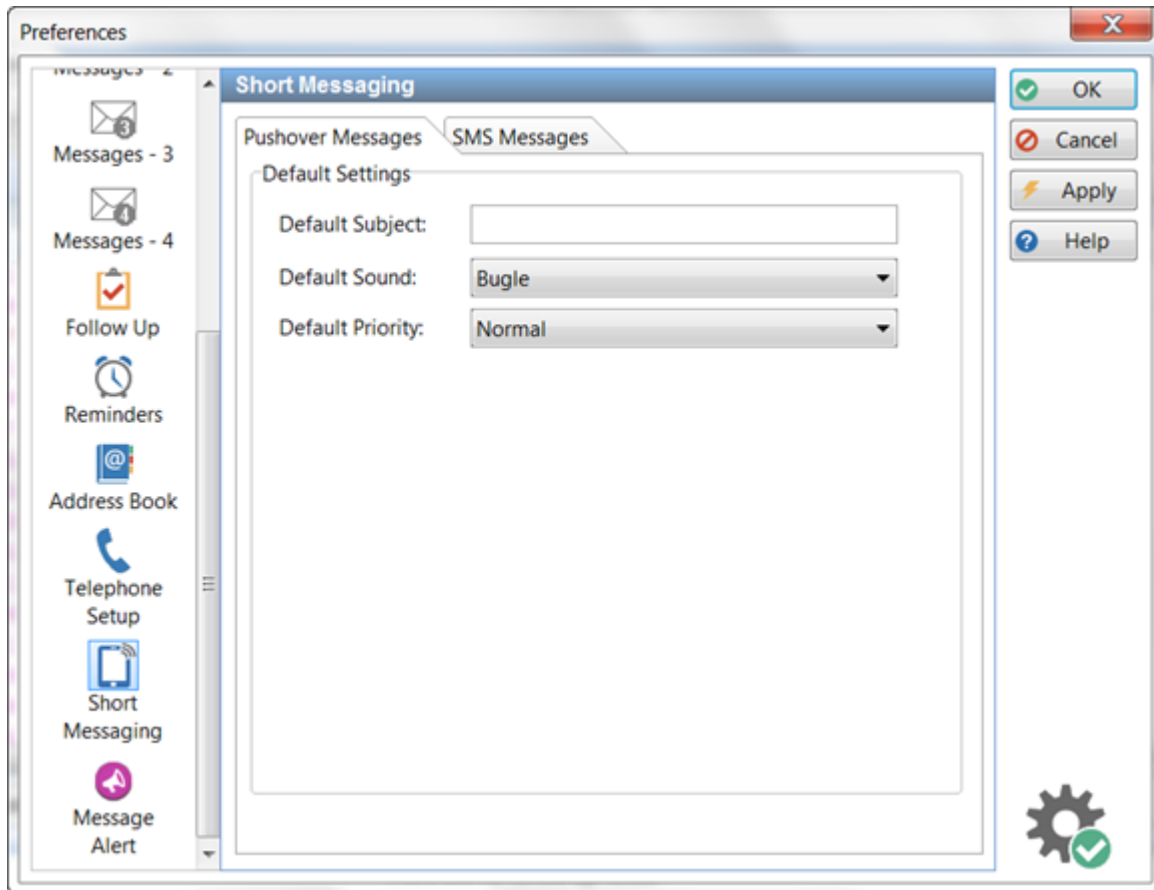

Default Subject	This text will be automatically added to all new Pushover messages.
Default Sound	This is the default sound that will be played on the receiver's mobile device, eg. cell phone.
Default Priority	Sets the default priority for all new messages.

SMS Messages

There are optional default settings you can set for SMS messages.

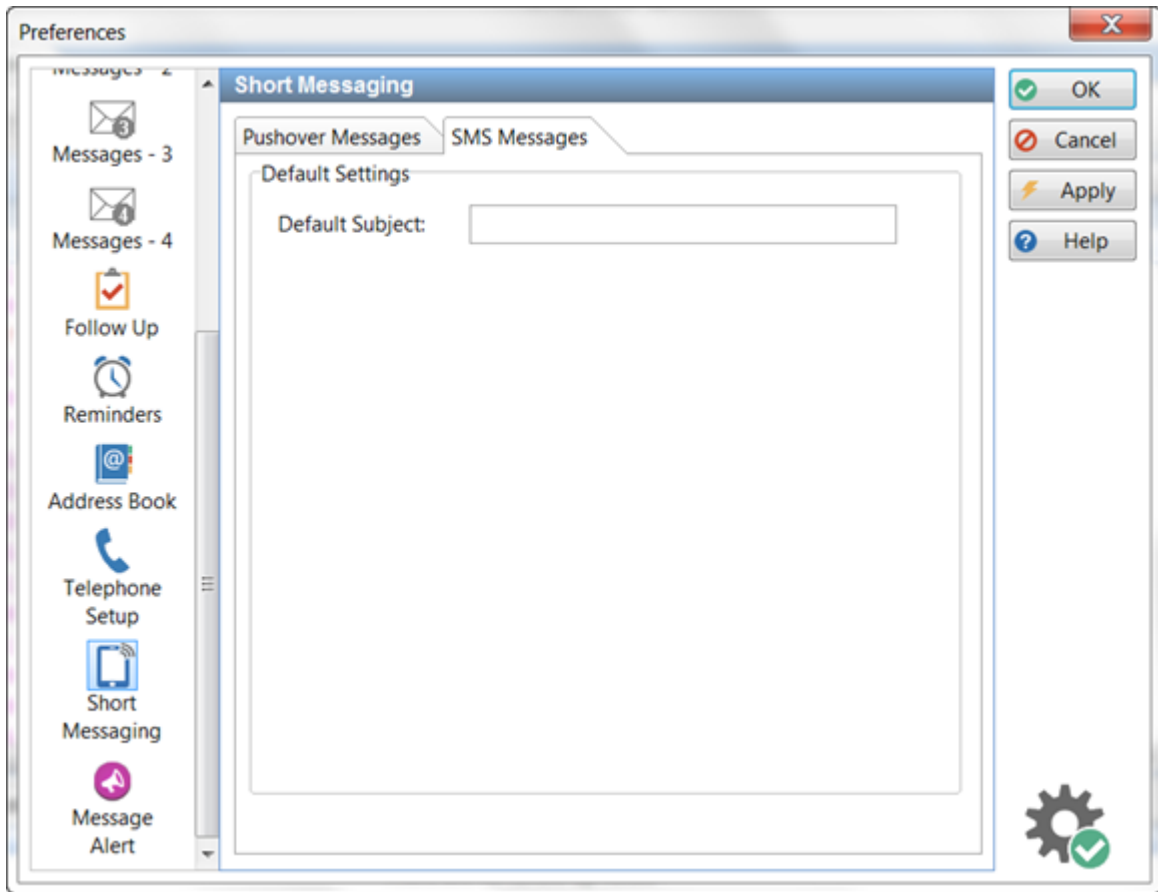

Default Subject	This text will be automatically added to all new SMS messages.
------------------------	--

Message Alert

These settings enable you to start and stop Message Alert automatically.

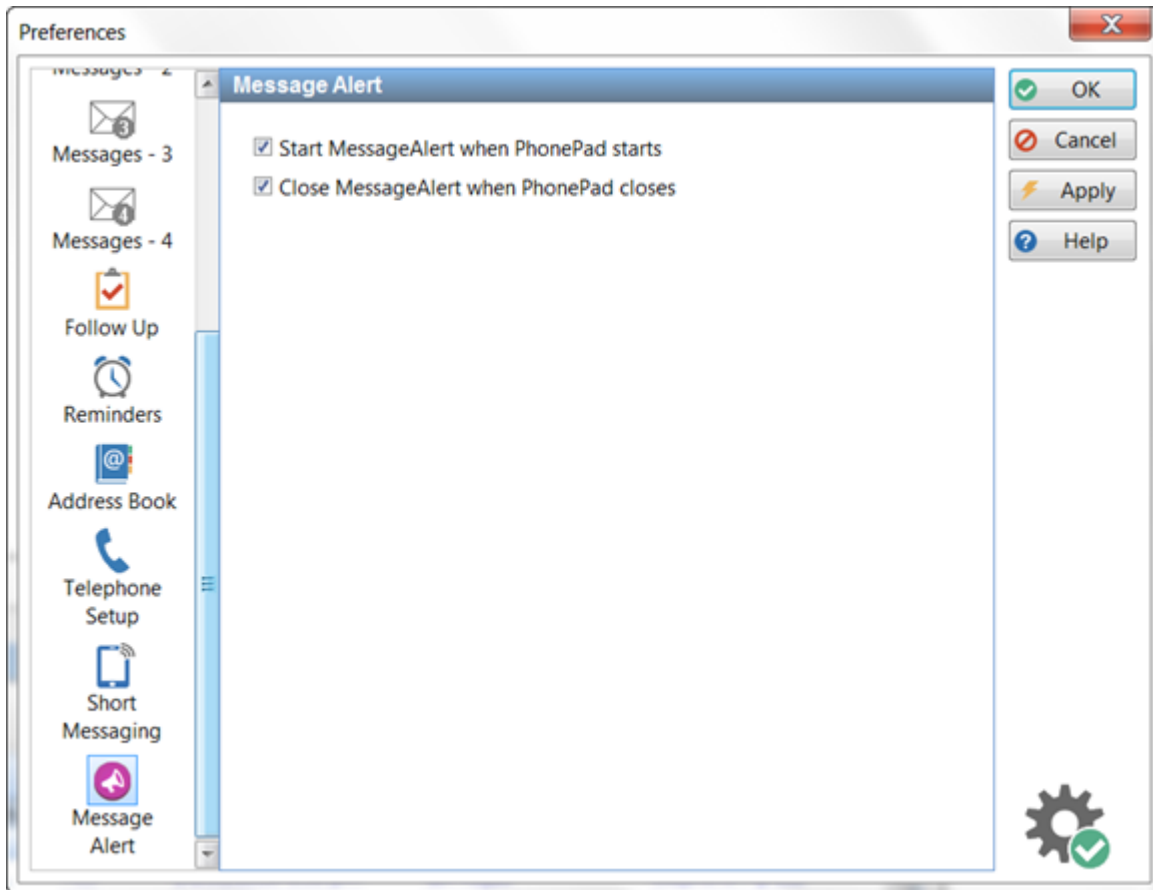

<p>Start Message Alert when PhonePad starts</p>	<p>When checked, PhonePad will launch Message Alert for you on startup.</p>
<p>Close Message Alert when PhonePad closes</p>	<p>When checked, PhonePad will close Message Alert when you exit PhonePad.</p>

Voice Announcements

With the **Voice Announcements** settings you can have PhonePad greet you when you log in, say goodbye when you log out, let you know when you have new messages, and more.

You can select either a Female or Male voice for each announcement. Click the musical note button to preview the selecting announcement.

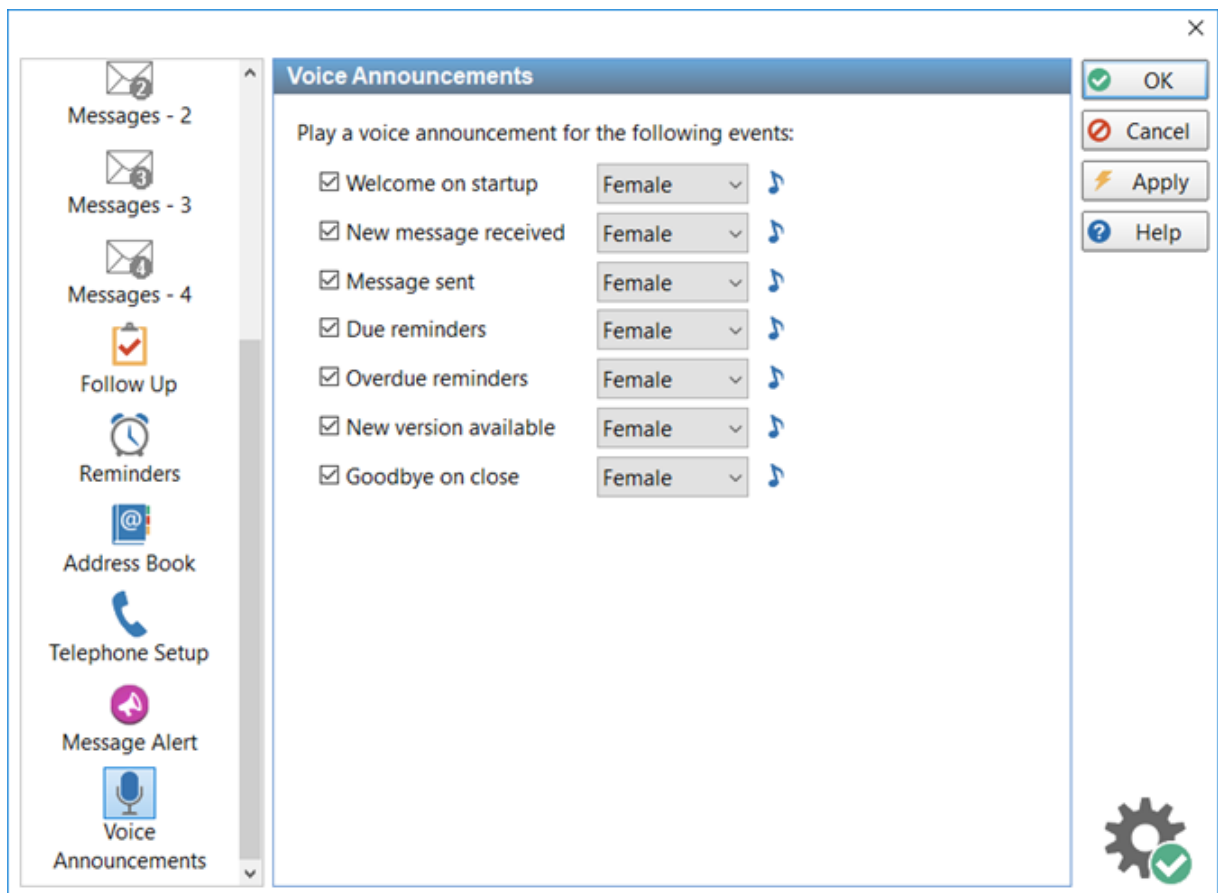

Welcome on startup	When checked, PhonePad will greet you when you log in.
New message received	When checked, PhonePad you tell you when there are new messages.

Message sent	When checked, you will receive a voice notification when a message is sent.
Due reminders	When checked, due reminders will be announced
Overdue reminders	When checked, overdue reminders will be announced.
New version available	When checked, PhonePad will let you know if there is a new version available.
Goodbye on close	When checked, PhonePad will farewell you when you log out.

Appointment Calendar

The settings relate to the Appointment Calendar.

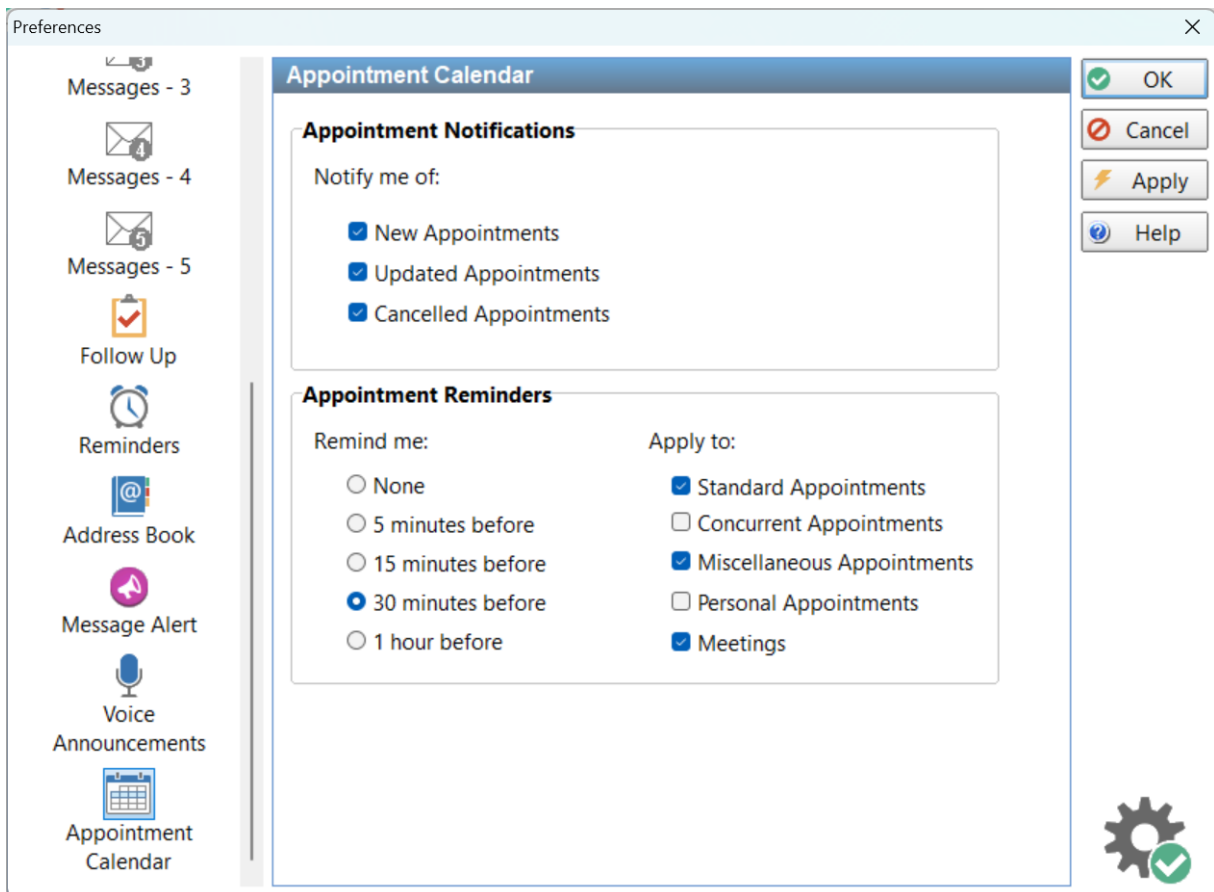

Appointment Notifications	
New Appointment s	When checked, you will receive a new appointment notification message in your PhonePad Inbox.
Updated Appointment s	When checked, you will receive a notification message when there are any updates to your appointments.
Cancelled Appointment s	When checked, you will receive a cancelled appointment notification message in your PhonePad Inbox.
Appointment Reminders	
Remind me	Set how long in advance you want to be reminded of an appointment.
Apply to	Set which appointment types you want reminders for.

This page intentionally left blank.

Chapter

11

Automatic Message Forwarding

Automatic Message Forwarding

Automatic Message Forwarding allows you to receive your PhonePad 5 messages via email, or have them sent directly to your cell/mobile phone using SMS or Pushover.

This is ideal for users that work remotely, are on the road, or are temporarily out of the office. To use this feature your PhonePad administrator must install MessageSender and configure PhonePad to use Automatic Message Forwarding.

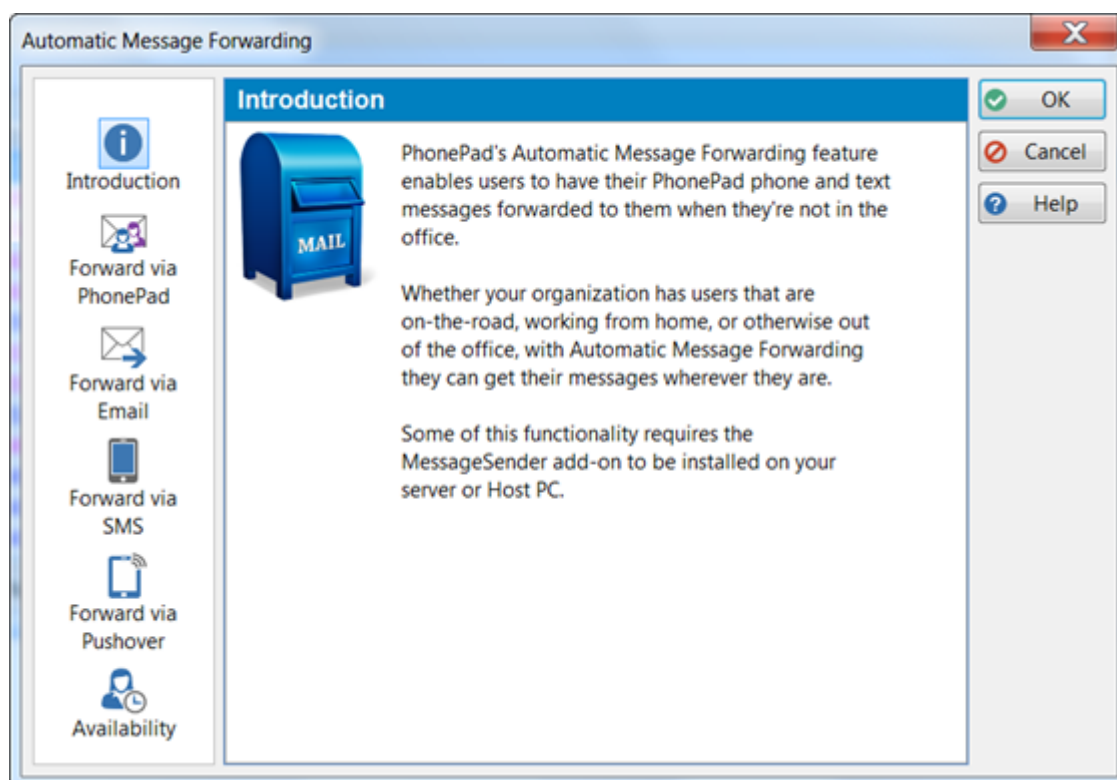

Forward to Other PhonePad Users

If you're away from the office for an extended period then you might want to have your messages forwarded to other users who can handle the messages for you in your absence.

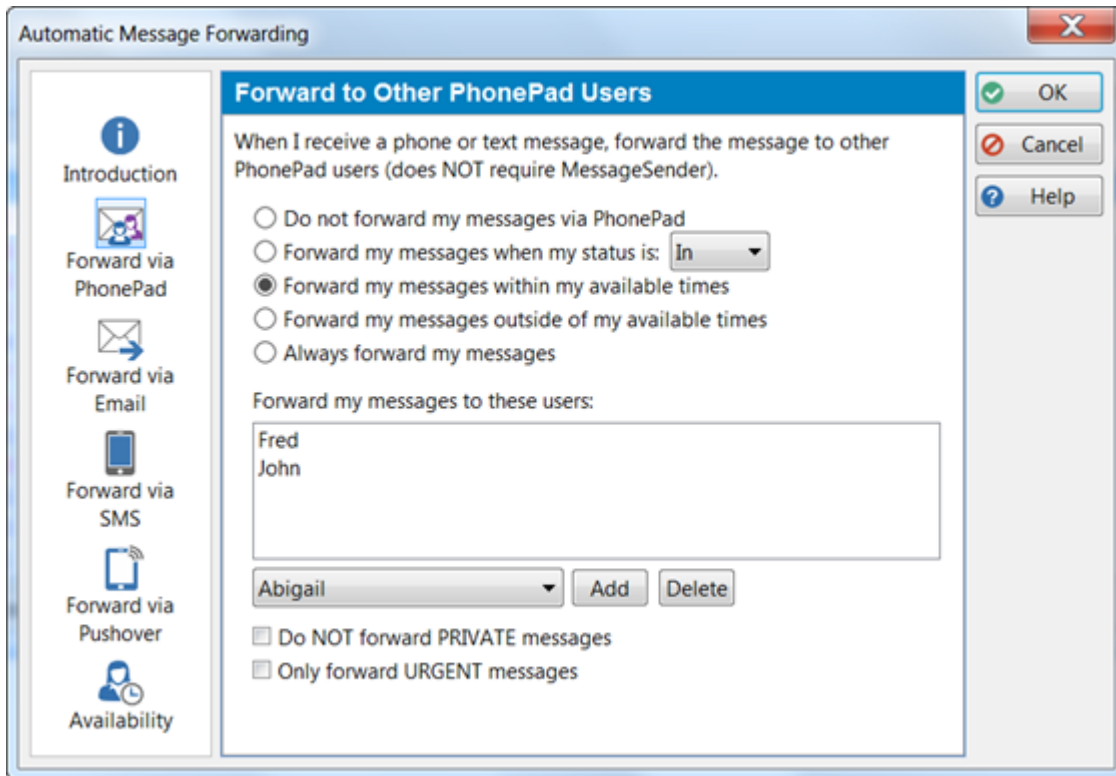

<p>Do not forward my messages via PhonePad</p>	<p>No messages will be forwarded to other users.</p>
<p>Forward my messages when my status is x</p>	<p>Select this option to forward your messages when your WhereRU status matches the selected value from the drop-down list.</p>
<p>Forward my messages within my available times</p>	<p>When selected, messages will be forwarded based on your availability.</p>
<p>Forward my messages outside of</p>	<p>When selected, messages will be forwarded based on your availability</p>

my available times	
Always forward my messages	Your messages will always be forwarded to the specified users.
Forward my messages to these users	Enter the names of the users you want messages to be forwarded to by selecting their names from the drop-down list and clicking the Add button. Users can be removed by selecting their name in the list and clicking the Delete button.
Do NOT forward PRIVATE messages	When checked, only non-Private messages will be forwarded.
Only forward URGENT messages	When checked, only Urgent messages will be forwarded.

This feature does **not** require MessageSender.

Forward Via Email

When you're not in the office, or maybe even when you are, you can have your PhonePad 5 messages forwarded to one or more email addresses.

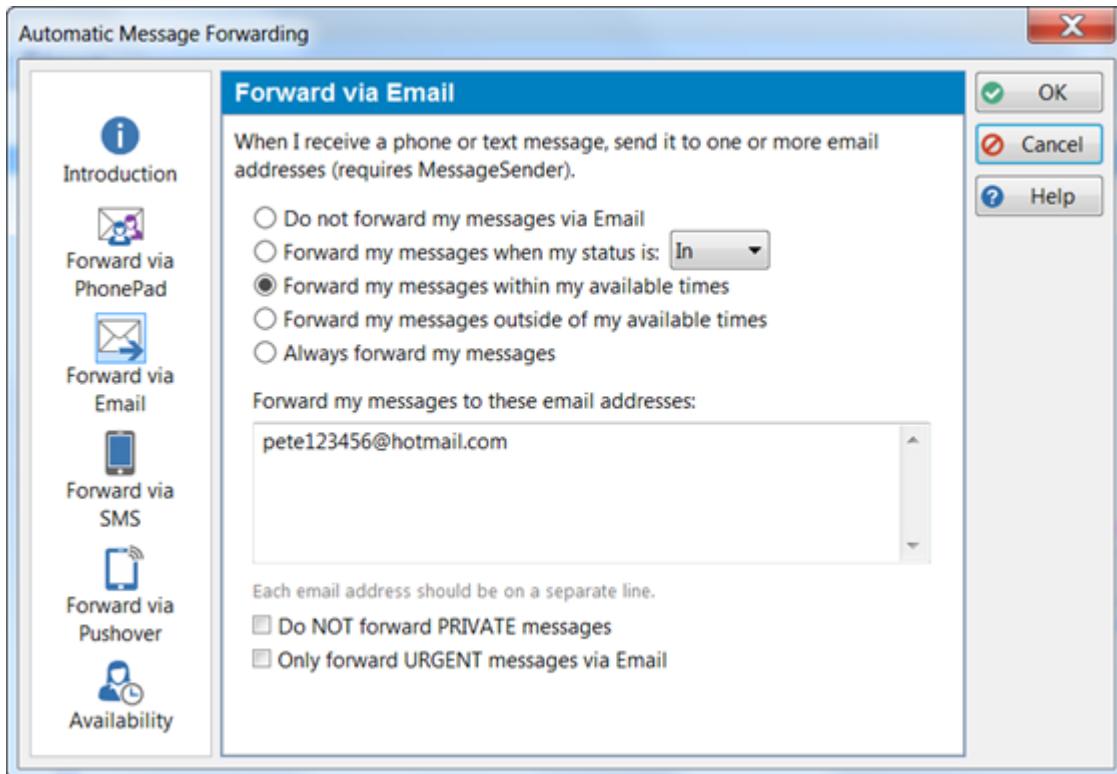

Do not forward my messages via Email	No messages will be forwarded to other users.
Forward my messages when my status is x	Select this option to forward your messages when your WhereRU status matches the selected value from the drop-down list.
Forward my messages within my available times	When selected, messages will be forwarded based on your availability.
Forward my messages outside of	When selected, messages will be forwarded based on your availability

my available times	
Always forward my messages	Your messages will always be forwarded to the specified users.
Forward my messages to these email addresses	Enter the email addresses you want to forward your messages to. Each email address should be on a separate line.
Do NOT forward PRIVATE messages	When checked, only non-Private messages will be forwarded.
Only forward URGENT messages	When checked, only Urgent messages will be forwarded.

This feature **does** require MessageSender to be installed on your Server or Host PC by your PhonePad administrator.

Forward Via SMS

You can have your messages sent to your cell/mobile phone via SMS (Short Messaging Service). Whether you're a lawyer in court, a business person in a meeting, a tradesman on the road, or a doctor doing your rounds, it's a great way to receive your phone messages when you're not in the office.

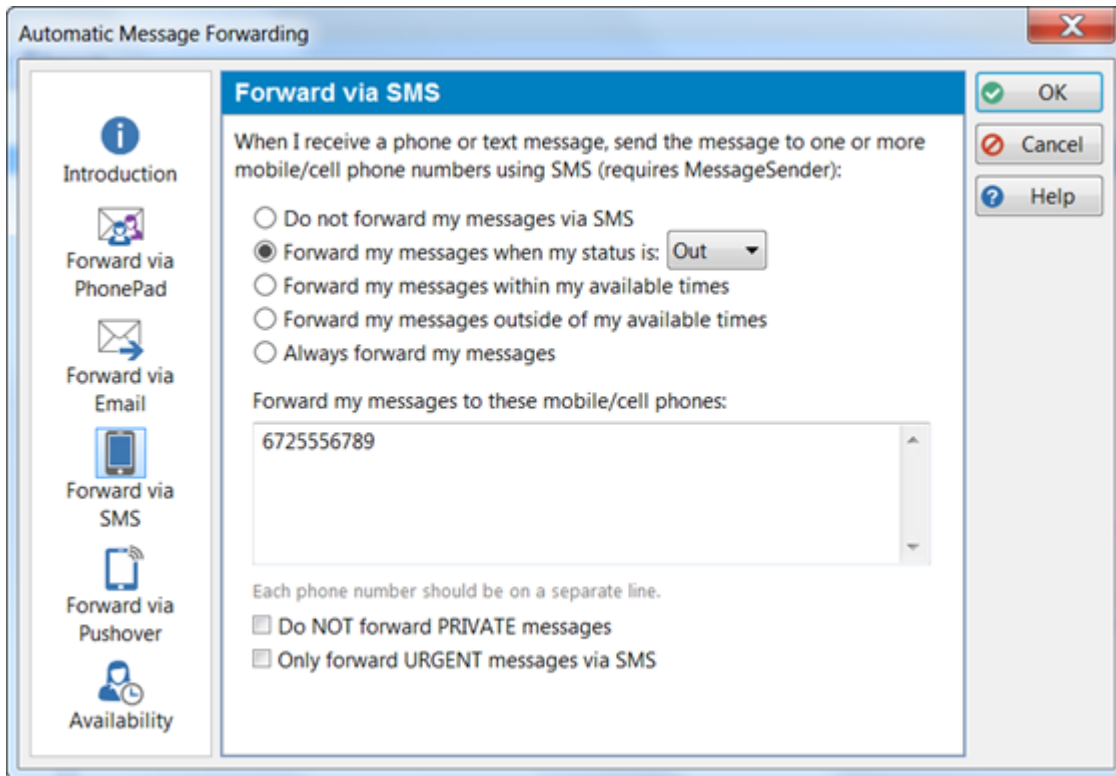

Do not forward my messages via SMS	No messages will be forwarded to other users.
Forward my messages when my status is x	Select this option to forward your messages when your WhereRU status matches the selected value from the drop-down list.
Forward my messages within my available times	When selected, messages will be forwarded based on your availability.
Forward my messages outside of	When selected, messages will be forwarded based on your availability.

my available times	
Always forward my messages	Your messages will always be forwarded to the specified users.
Forward my messages to these cell/mobile numbers	Enter the email addresses you want to forward your messages to. Each cell/mobile number should be on a separate line.
Do NOT forward PRIVATE messages	When checked, only non-Private messages will be forwarded.
Only forward URGENT messages	When checked, only Urgent messages will be forwarded.

This feature **does** require MessageSender to be installed on your Server or Host PC by your PhonePad administrator.

Forward Via Pushover

Have your phone messages forwarded directly to an app on your mobile device without using an SMS network.

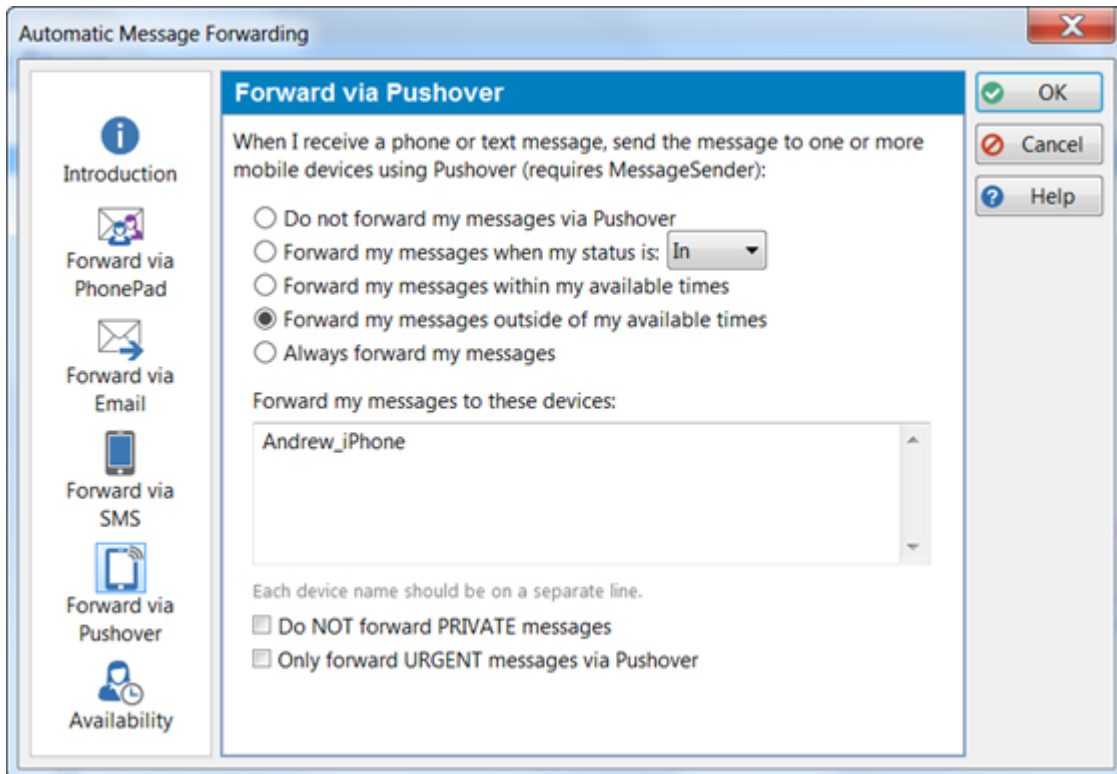

Do not forward my messages via Pushover	No messages will be forwarded to other users.
Forward my messages when my status is x	Select this option to forward your messages when your WhereRU status matches the selected value from the drop-down list.
Forward my messages within my available times	When selected, messages will be forwarded based on your availability.
Forward my messages outside of	When selected, messages will be forwarded based on your availability

my available times	
Always forward my messages	Your messages will always be forwarded to the specified users.
Forward my messages to these devices	Enter the email addresses you want to forward your messages to. Each device should be on a separate line.
Do NOT forward PRIVATE messages	When checked, only non-Private messages will be forwarded.
Only forward URGENT messages	When checked, only Urgent messages will be forwarded.

This feature **does** require MessageSender to be installed on your Server or Host PC by your PhonePad administrator.

Availability Settings

The **Availability** tab allows you to specify what days and times you are (and aren't) available by selecting the check boxes for the relevant days and setting the start and end times. The settings affect all of the previous options.

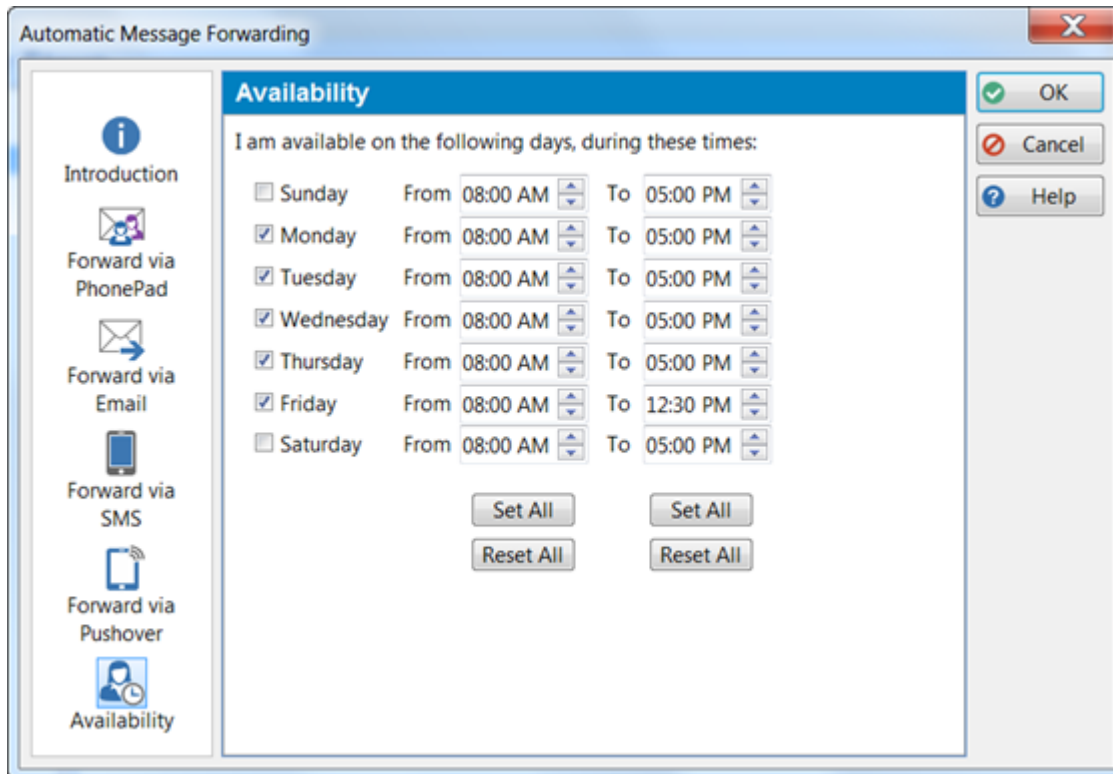

When the check box for a day of the week is checked, the times for that day are used by *Automatic Message Forwarding* based on the settings you make with **Forward via PhonePad**, **Forward via Email**, **Forward via SMS** and **Forward via Pushover**.

Important Information About Automatically Forwarded Emails

When an email is sent by MessageSender, it will add a special code to the Subject that's called an MID (Message Identifier).

MIDs are unique codes that are used by MessageSender to track emails. They are not only unique in your system, but also unique amongst every PhonePad site in the world.

It is **essential** that, when replying to received emails, that the user doesn't alter or remove this code. They can alter the rest of the Subject line but **not** the MID code. Otherwise, email replies, Read Receipts and Message Delivery Failures won't get sent back to PhonePad.

Here's an example of what we're talking about.

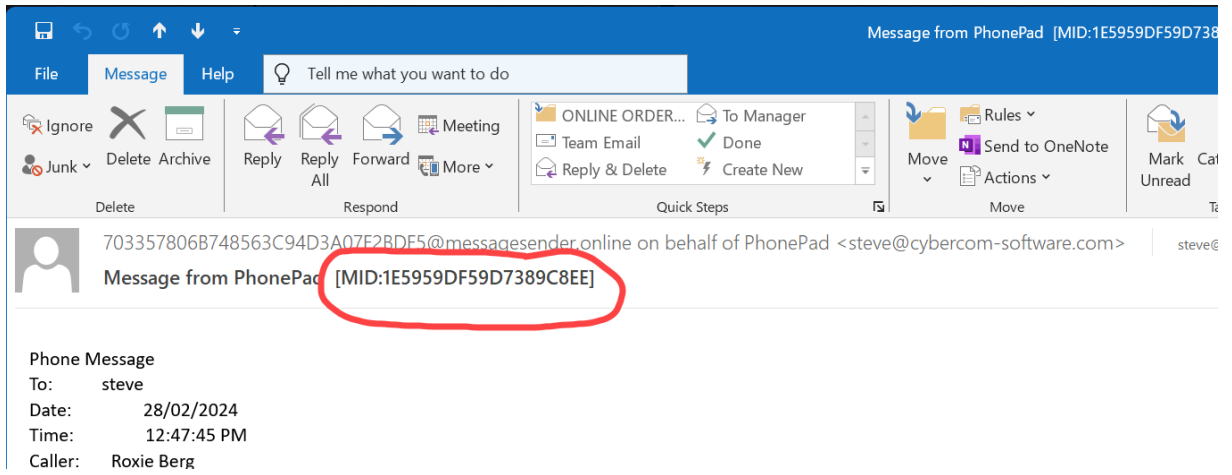

Chapter

12

Address Book

Address Book

PhonePad has its own built-in Address Book for storing all of your contacts. Any caller information you enter when sending a message will be automatically added to the Address Book if the information doesn't already exist. You can add entries to the Address Book manually or import them from file.

To access the Address Book, click on the **Address Book** button on the **Home** tab of the toolbar, or select **Address Book** from the **Tools** menu.



The Address Book main window will be displayed.

Fullname	Firstname	Lastname	Company	Business Phone	Bus
Mathew Abbott	Mathew	Abbott	Lester Enterprises	9881838	
Ashlee Abbott	Ashlee	Abbott	Avery Co	8018747	
Kaye Abbott	Kaye	Abbott	Bullock Enterprises	5860522	
Tammi Acevedo	Tammi	Acevedo	Castillo Inc	6043750	
Arnold Acevedo	Arnold	Acevedo	Wilkinson Pty Ltd	9054361	
Freddie Acevedo	Freddie	Acevedo	Espinoza Enterprises	6998896	
Inez Acevedo	Inez	Acevedo	Hendricks and Associates	6277135	
Mallory Acosta	Mallory	Acosta	Riddle and Associates	9670982	
Natalie Acosta	Natalie	Acosta	Montoya Limited	9546962	
Miguel Acosta	Miguel	Acosta	Dudley Corporation	5910452	
Angela Acosta	Angela	Acosta	Stevenson Corporation	9866973	
Misty Adams	Misty	Adams	Mclaughlin LLC	6337445	
Sherri Adams	Sherri	Adams	Summers Inc	6859756	
Marcella Adams	Marcella	Adams	Berry Company	9143066	
Pansy Adams	Pansy	Adams	Ashley Enterprises	9492276	
Cheri Adams	Cheri	Adams	Reeves Co	6182083	
Concetta Adams	Concetta	Adams	Welch Corp	8017658	802
Lawrence Adams	Lawrence	Adams	Barron Limited	7423405	
Sally Adkins	Sally	Adkins	Petersen Corporation	6338454	
Tommie Adkins	Tommie	Adkins	Page Inc	7260860	

Search for: in this column: Fullname

All **A** B C D E F G H I J K L M N O P Q R S T U V W X Y Z

Status: Found 164 entries under Lastname starting with A.

- 1 The Address Book list is where all of your contacts will appear. You can click a column heading to sort by that column.

2	Click to <i>Add</i> a new entry.
3	Click to <i>Edit</i> the selected entry. You can also double-click on the entry.
4	Click to <i>Delete</i> the selected entry.
5	Click to <i>View</i> the selected entry.
6	Click to <i>Print</i> all Address Book entries.
7	Click to <i>Import</i> Address Book entries.
8	Click to <i>Export</i> all Address Book entries.
9	Click to delete all Address Book entries. WARNING: This complete delete all Address Book entries and cannot be undone.
10	Click to select the columns you want displayed in the Address Book list.
11	Click to view a complete history of all phone messages and follow up notes for the selected contact.
12	Click to open the Address Book settings page in Preferences.
13	Click to close the Address Book.
14	Click to display online help.
15	You can search all Address Book entries using the search facility. Enter search text under the Search for field.
16	This is the Search button.
17	This button clears the search.
18	Select the column you want to search, then click the Search button.
19	You can use the letter tabs to view entries that begin with the selected tab.

Some buttons may be disabled, depending on what Address Book access your PhonePad administrator has given you.

Address Tabs

At the bottom of the Address Book window there is an address tab, similar to what you get with paper address books.

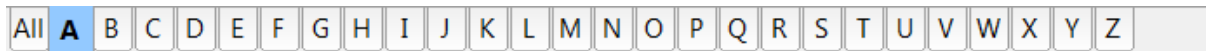

Click a tab from **A** to **Z** to view contact names starting with that letter (either the firstname or lastname, depending on your Address Book settings under **View/Preferences/Address Book**).

Click the **All** tab to view all entries in your Address Book. If you have a lot of entries this may take a few seconds.

Add an Address Book Entry

To add a new Address book entry (or Caller), click the **Add** button.

The top part of the screen contains the **Caller** Information area. The **Fullname** field is a mandatory field as it is used by PhonePad to look up caller information.

The rest of the screen contains a number of tabbed pages:

- General
- Business
- Postal
- Home
- Map
- Family
- Notes
- Documents

Your PhonePad Administrator can configure which tabs are displayed on this screen, so not all of the tabs described here may appear.

Caller Information

Fullname	This field is mandatory. When you enter a name in the Fullname field it will be automatically separated into the Firstname, Middlename and Lastname fields. Of course, you can always edit this fields if you wish.
-----------------	---

Job Title	You can enter a job title or position in this field.
Company	Enter a company name if relevant (you can rename this to something else if it makes more sense for your business).

General Tab

Title	Select or enter a title, eg. Ms.
Firstname	This field is automatically populated when you enter a name in the Fullname field, but you can also manually enter a Firstname.
Middlename	This field is automatically populated when you enter a name in the Fullname field, but you can also manually enter a Middlename.
Lastname	This field is automatically populated when you enter a name in the Fullname field, but you can also manually enter a Lastname.

Suffix	Anything that comes after the name, like Esq.
Job Title	Their position title, eg. CEO.
Date of Birth	When you select a birth date the Age Now will be automatically calculated.
Age Now	This field is automatically populated with the caller's age, based on the Date of Birth.
Date of Death	It's a bit morbid but your business may need this.
Identification	You can enter text in this field that identifies the entry. For example, you could enter a client number, patient number, etc.
Contact Type	Select a Contact Type from the drop-down list. These are added by your PhonePad administrator.
Best Contact Number	Contacts can have a lot of phone numbers in the Address Book, so this field can contain the best number to contact them on.
Load Save Clear	Use the Load button to load a photo for the contact. Use the Save button to save the photo. Use the Clear button to clear the photo.
Private Entry	When checked, only you will be able to view this entry.

Business Tab

These fields on the **Business** tab should be self-explanatory.

Add Entry

Caller Information

Fullname: Michael Jones

Job Title:

Company: Jones Inc

General Business Postal Home Map Family Notes

Address 1: 123 First Avenue

Address 2:

City: New York State: NY Postal Code: 10003

Country: USA

Telephone: 555 6666 Ext: Alt. Phone: 555 7777

Fax: Cell/Mobile: 555 8888

Email:

Website:

OK Cancel Print Help

Postal Tab

These fields on the **Postal** should be self explanatory.

The screenshot shows the 'Add Entry' dialog box. At the top, the title bar reads 'Add Entry' with a close button. Below the title bar is the 'Caller Information' section, which includes three input fields: 'Fullname:' containing 'Michael Jones', 'Job Title:' which is empty, and 'Company:' containing 'Jones Inc'. Below this section is a horizontal row of tabs: 'General', 'Business', 'Postal', 'Home', 'Map', 'Family', and 'Notes'. The 'Home' tab is currently selected. Under the 'Home' tab, there are several input fields: 'Address 1:', 'Address 2:', 'City:', 'State:', 'Postal Code:', and 'Country:'. To the right of the main form area, there is a vertical stack of four buttons: 'OK' (with a green checkmark icon), 'Cancel' (with a red 'X' icon), 'Print' (with a printer icon), and 'Help' (with a question mark icon).

Home Tab

The fields on the **Home** should be self explanatory.

Add Entry

Caller Information

Fullname: Michael Jones

Job Title:

Company: Jones Inc

General Business Postal Home Map Family Notes

Address 1:

Address 2:

City: State: Postal Code:

Country:

Telephone: Alt. Phone:

Fax: Cell/Mobile:

Email:

OK Cancel Print Help

Map Tab

The **Map** tab can show the caller's location using Google Maps based on their **Business**, **Postal** or **Home** address. You will need to enter an address on the **Business**, **Postal** and/or **Home** tabs before you can use the **Map** feature.

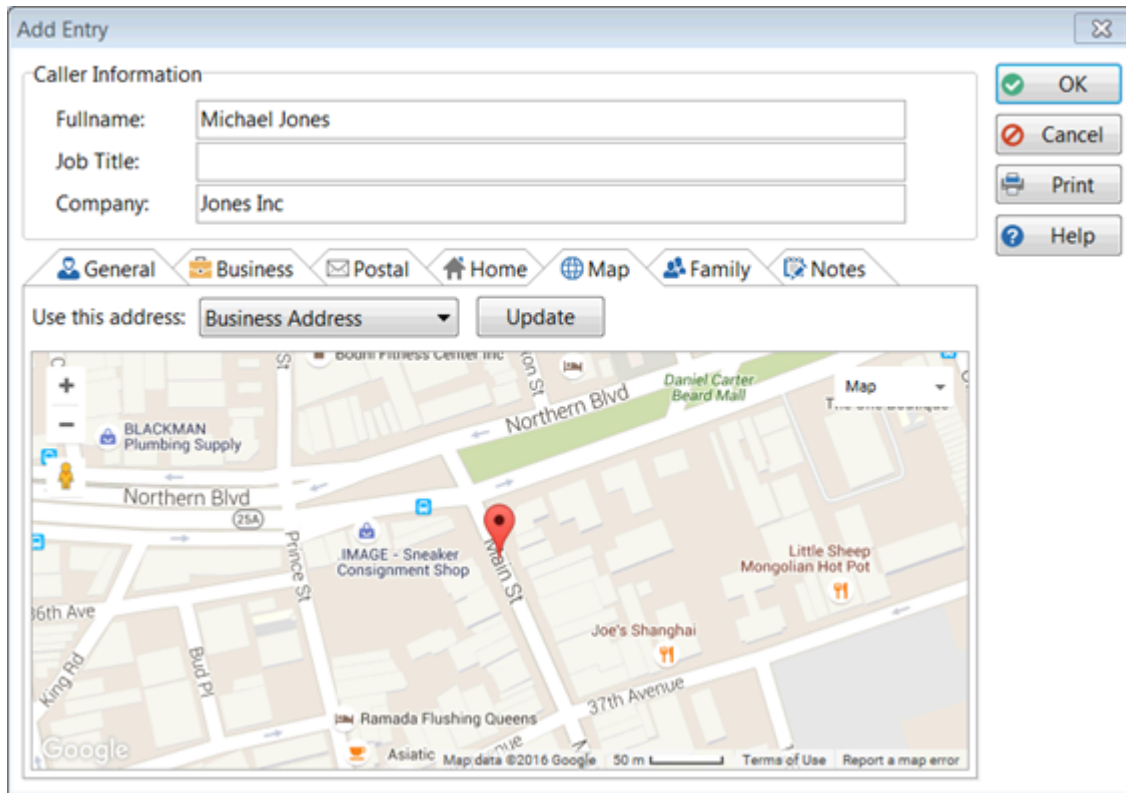

To load the map, select **Business Address**, **Postal Address** or **Home Address** and click the **Update** button. It may take up to a minute or so, depending on the speed of your Internet connection.

A marker will show the address. You can zoom and pan the map, just as you can on the Google Maps website.

When you save the new address book entry the map will be saved in the database as a *static image*. This avoids having to load the map each time from Google Maps.

If you want to update the map you can do this at any time by clicking the **Update** button.

Family Tab

The **Family** tab allows you to enter a spouse's name and date of birth, as well as the names and dates of births for up to 6 children. It includes email address and phone numbers for their Spouse.

Update Entry

Caller Information

Fullname:

Company:

General Business Postal Home Map Family

Spouse

	Date of Birth	Age Now
Fullname: <input type="text"/>	<input type="text" value="v"/>	<input type="text" value=""/>
Firstname: <input type="text"/>	Work Phone: <input type="text"/>	
Middlename: <input type="text"/>	Mobile/Cell: <input type="text"/>	
Lastname: <input type="text"/>		
Email: <input type="text"/>		

Children

	Date of Birth	Age Now
Child 1: <input type="text"/>	<input type="text" value="v"/>	<input type="text" value=""/>
Child 2: <input type="text"/>	<input type="text" value="v"/>	<input type="text" value=""/>
Child 3: <input type="text"/>	<input type="text" value="v"/>	<input type="text" value=""/>
Child 4: <input type="text"/>	<input type="text" value="v"/>	<input type="text" value=""/>
Child 5: <input type="text"/>	<input type="text" value="v"/>	<input type="text" value=""/>
Child 6: <input type="text"/>	<input type="text" value="v"/>	<input type="text" value=""/>

OK Cancel Print Help

Notes Tab

The **Notes** tab is divided into 10 tabs which allow you to keep an almost unlimited amount of notes. The names and colors of the tabs can be customized in System Rules.

Update Entry

Caller Information

Fullname: Mathew Abbott

Company: Lester Enterprises

OK

Cancel

Print

Help

Postal Home Map Family **Notes** Documents

Some Notes More Notes Even More Notes Notes 4 Notes 5 Notes 6

Notes 1

Documents Tab

On the **Documents** tab you can store documents for the Address Book entry.

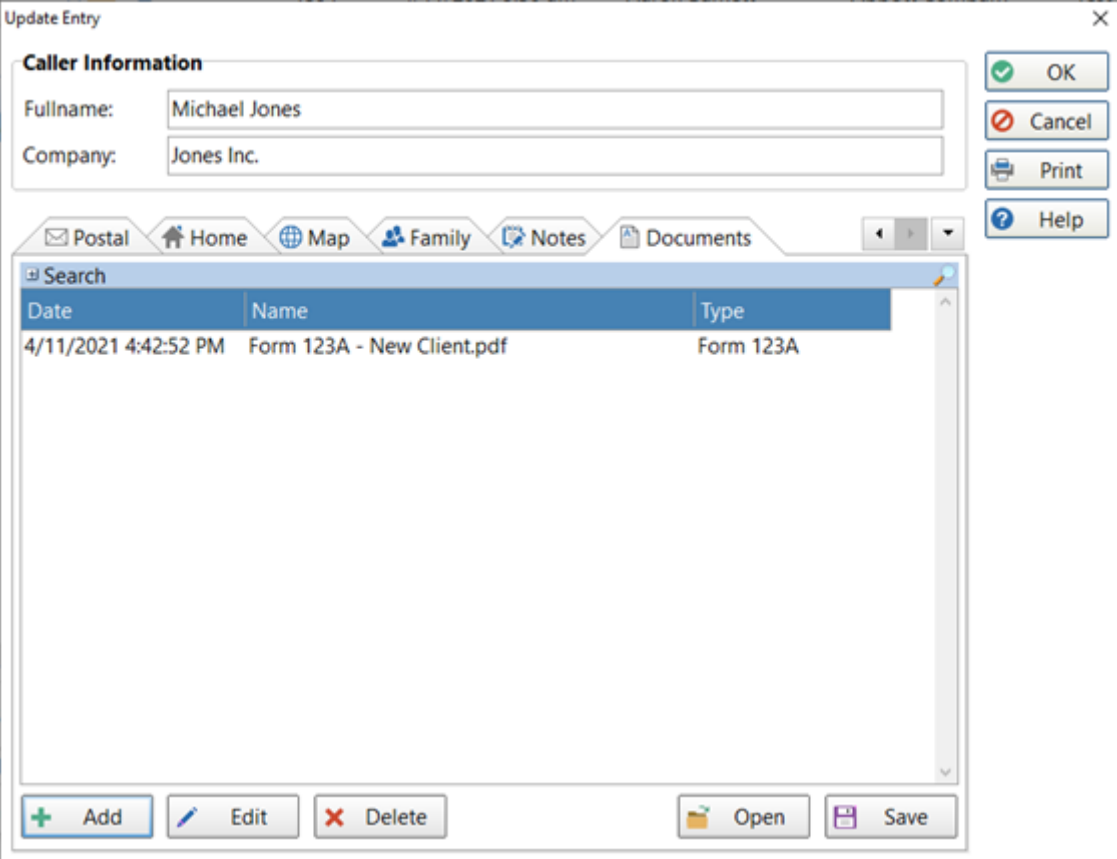

Update Entry

Caller Information

Fullname: Michael Jones

Company: Jones Inc.

OK

Cancel

Print

Help

Postal Home Map Family Notes Documents

Search

Date	Name	Type
4/11/2021 4:42:52 PM	Form 123A - New Client.pdf	Form 123A

Add Edit Delete Open Save

Please refer to Documents for more details.

Buttons

Click the **OK** button to add the new entry to the Address Book.

Click the **Cancel** button to cancel the addition.

Click the **Print** button to print the entry. Here is an example of a print out:

Edit an Address Book Entry

To edit an Address Book entry (or Caller), select the entry and click the **Edit** button, or double-click on the entry.

The information for adding an Address Book entry also applies to editing (or updating) an Address Book entry.

Delete an Address Book Entry

To delete an entry, select the entry and click the **Delete** button.

You will be asked to confirm the deletion.

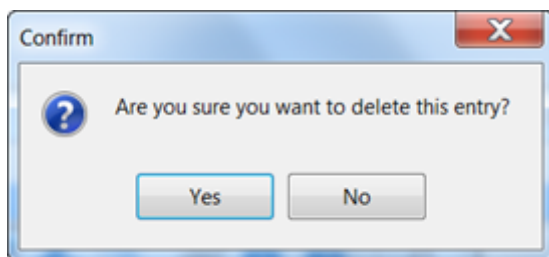

View an Address Book Entry

To view an Address Book entry, select the entry from the list and click the **View** button. You will not be able to edit the entry.

Print Address Book Entries

You can print an Address Book entry by editing or viewing the entry and clicking the **Print** button.

If you want to print the Address Book list, click **Print** on the Address Book main screen.

Importing Your Contacts

You can import contacts from a CSV file into the PhonePad Address Book. Click the **Import** button.

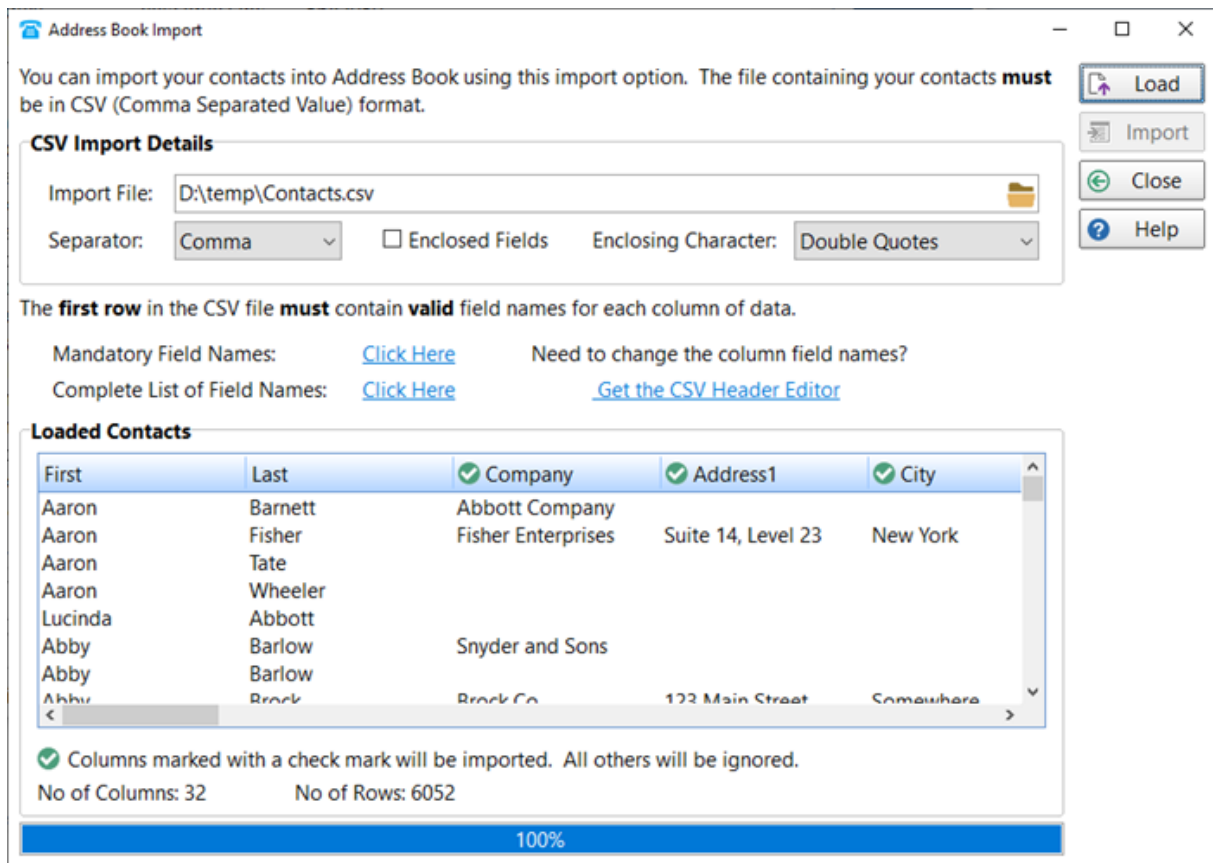

The first row of the file you are importing **must contain column names**.. The column names can be in any order but some of the columns must match required Address Book fields..

There are links you can click to view the list of Mandatory field names, and a list of all Address Book field names. If your CSV file doesn't contain the required column names, there is a link for downloading the CSV Header Editor.

List of All Address Book Field Names

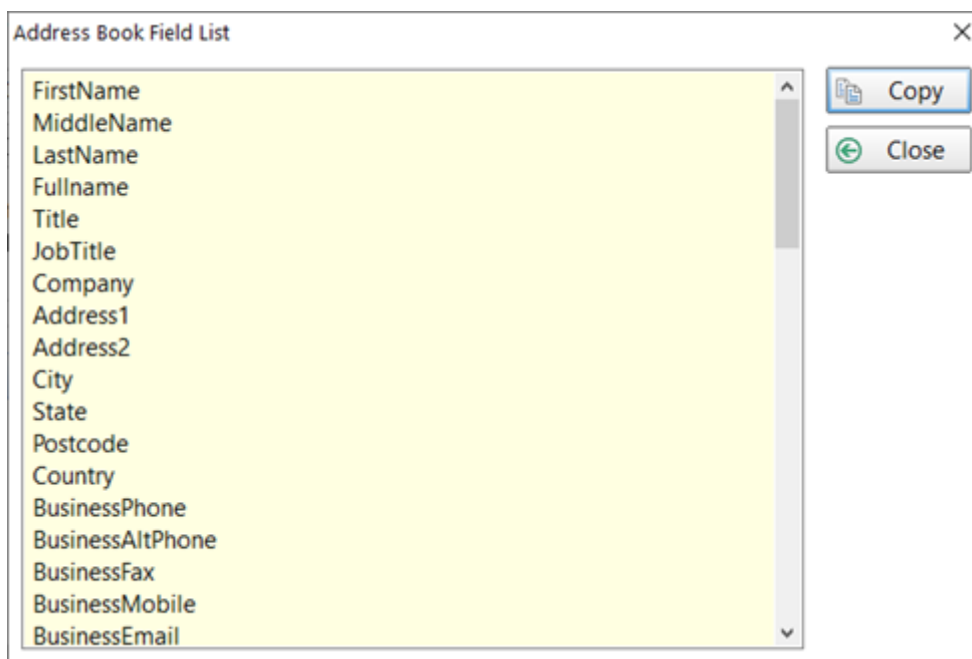

You can take a copy of the list by clicking the **Copy** button. If your CSV doesn't have the exact field names you will have to edit the names using a text file editor.

Importing From a CSV File

1. Select a file to import from.
2. The default settings will work with most CSV files. If necessary, select a **Separator** from the drop-down list, check the **Enclosed Fields** check box if needed, and select the **Enclosing Character**.
3. Click the **Load** button to load the contacts from the file.
4. Columns that correctly match the field names used by PhonePad will be marked with a green check mark icon. All other fields will be ignored and won't be imported.
5. Review the data to make sure it is correct, then click the **Import** button to import your contacts.

 The **Import** button will be disabled unless all mandatory fields are present in the CSV file..

Exporting Your Contacts

If you need to export your Address Book, click the **Export** button.

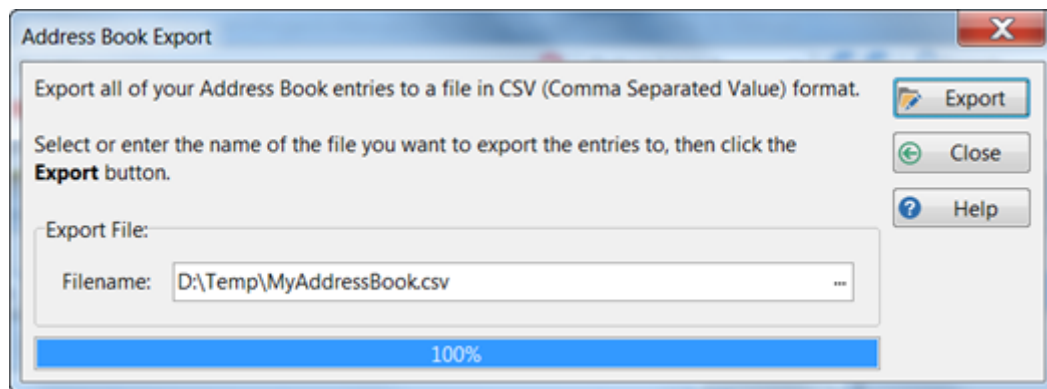

Enter a folder and filename to export to, then click the **Export** button.

Deleting All Entries

If you need to start over with your Address Book you can delete the entire Address Book by clicking the **Clear** button.

You will be asked to confirm this.

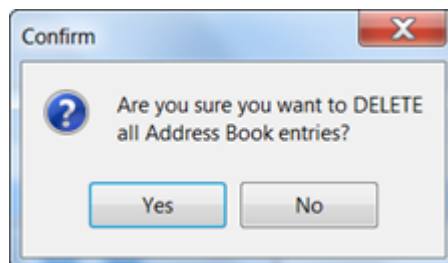

IMPORTANT: Once you have deleted all entries they cannot be recovered.

Setting the Columns

You can set some of the columns for display in the Address Book list. Click the **Columns** button.

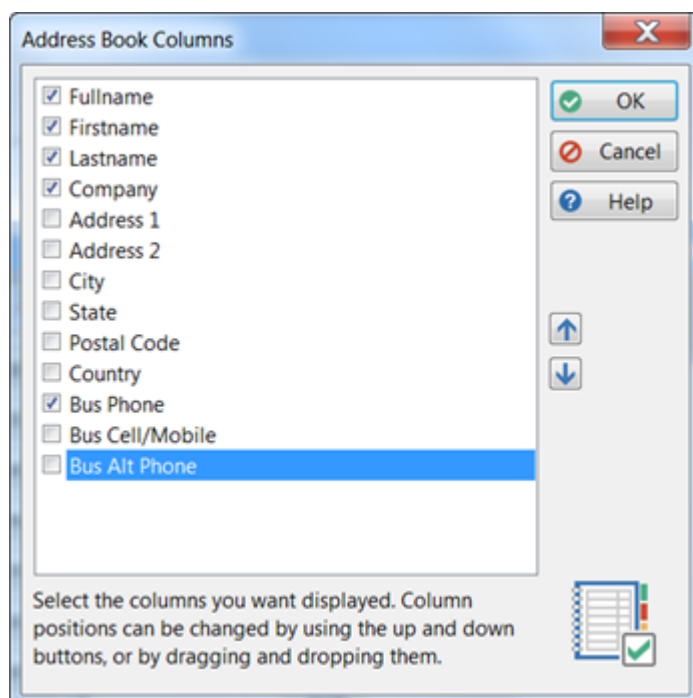

To display a column, make sure its check box is checked.

You can change the order of the columns by using the up and down arrow buttons. Alternatively you can move columns by dragging and dropping them.

Address Book Settings

This is a shortcut to the *Address Book* settings page in *Preferences*.

Searching

The *Address Book* has a built-in search function which is simple to use.

Search for:  in this column: ▼

1. Enter your search text under **Search for**.
2. Select a column to search from the drop-down list.

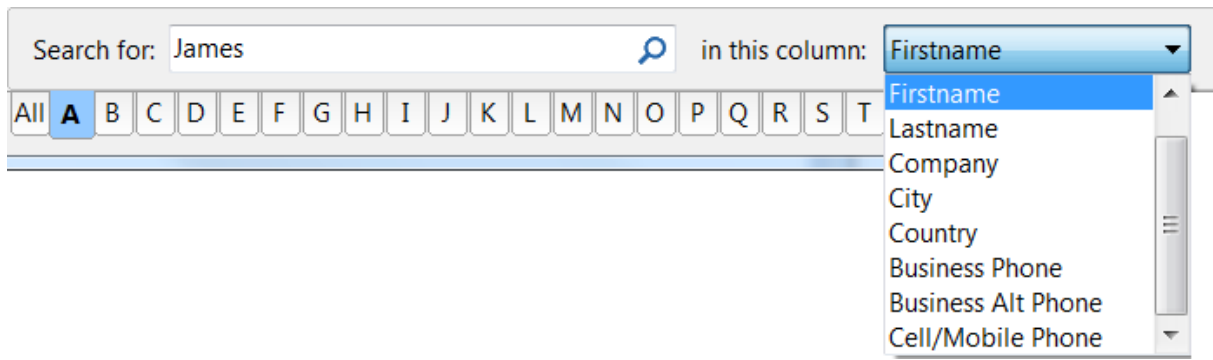

3. Click the **Search** button (the small button with the magnifying glass icon).
4. The results will be displayed in the Address Book list.

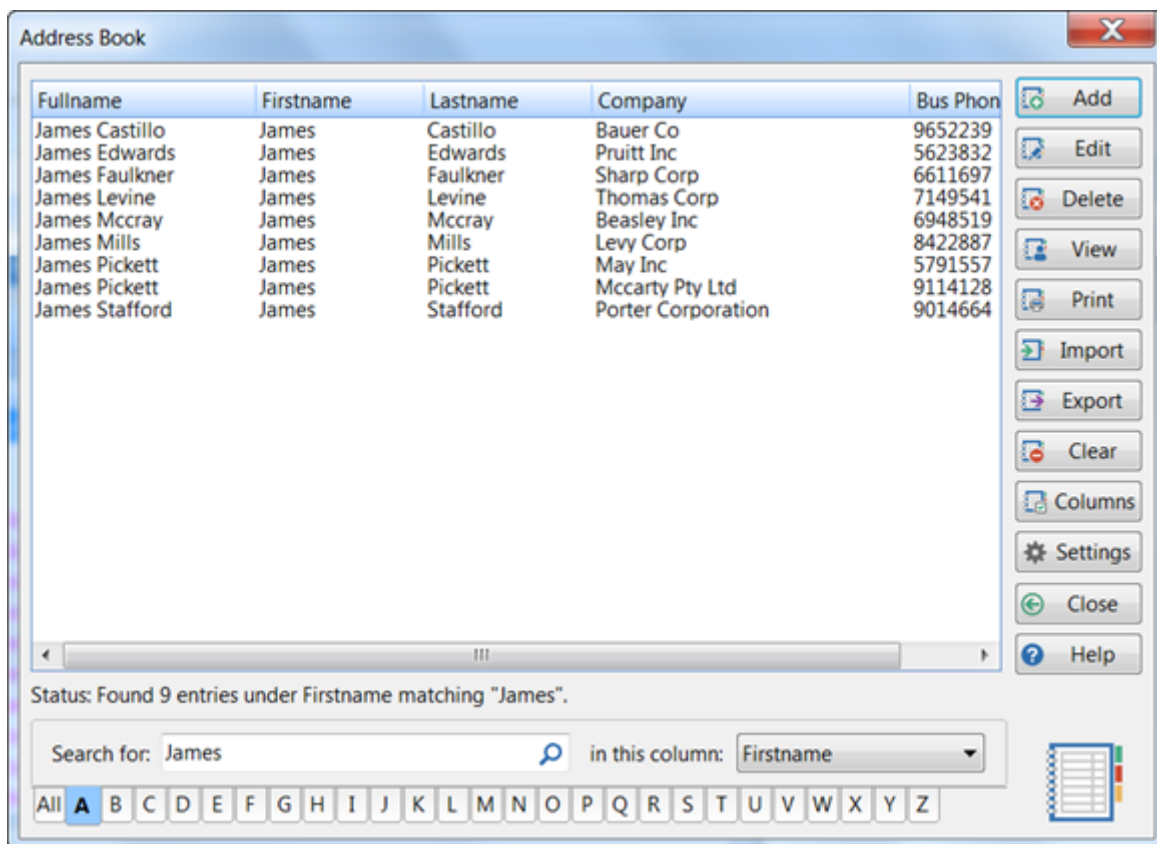

Documents

The PhonePad Address Book has a feature that enables you to stored an unlimited number of documents for each Caller (Address Book entry).

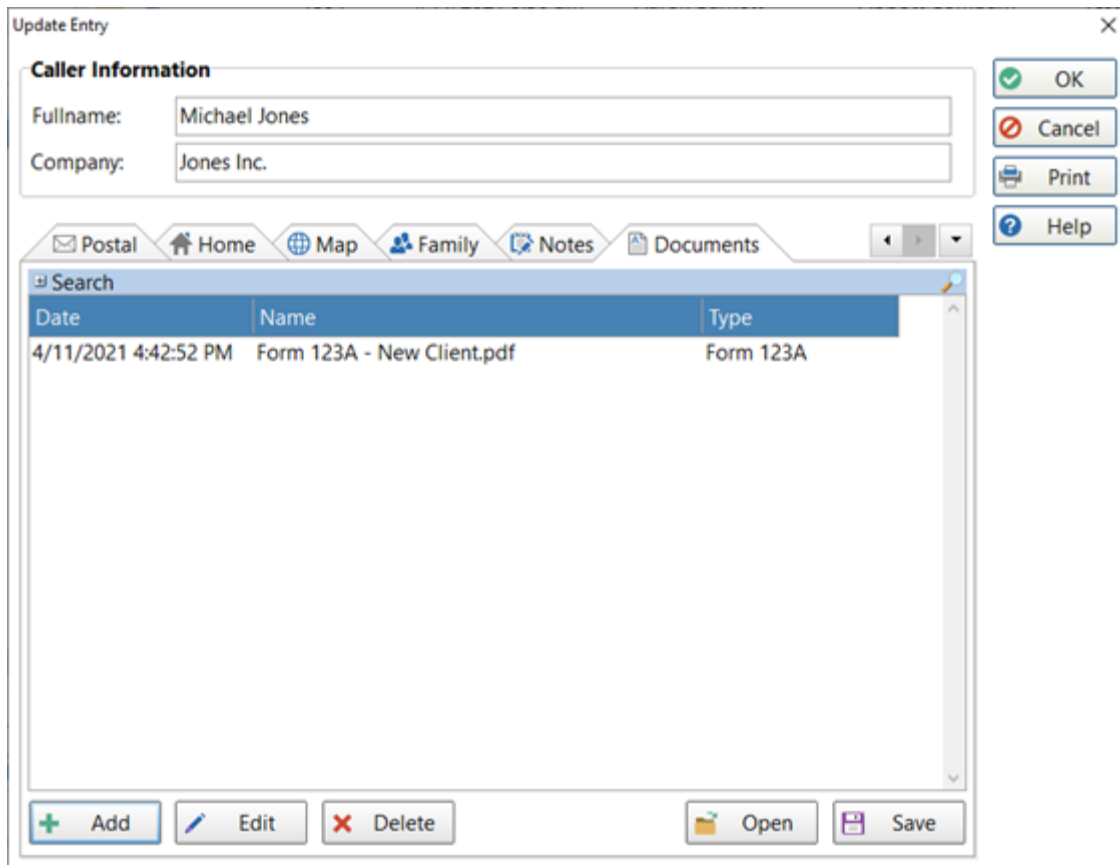

- Add** Add a new document.
- Edit** Edit the selected document.
- Delete** Delete the selected document.
- Open** Open the selected document.
- Save** Save the selected document as an external file.



Documents stored here are only for the selected Caller (Address Book entry). Each Caller has their own set of documents.

Adding a Document

To add a new document to the Address Book entry for the selected Caller, click the **Add** button.

The screenshot shows the 'Add Address Book Document' dialog box. The fields are filled with the following information:

- Filename:** D:\temp\Form 123A - New Client.pdf
- Document Name:** Completed Form 123A for Michael Jones.
- Document Type:** Form 123A
- Description:** Form has been completed.
- Keywords:** New Client, Jones
- New Keyword:** Form 123A

Filename Select or enter the location and name of the document.

Document Name Enter a name for the document. By default, the filename will be added but you can replace that text.

Document Type Select the Document Type from the list of types (these are set up under Lookup List Management). Optional.

Description Enter a description for the document. Optional.

Keyword Enter keywords to make it easier to find the document.

s

To enter a keyword, type in the **New Keyword** field, then click the *Plus* button or press <enter>.

To remove a keyword, click on the red cross button on the keyword.

Editing a Document

To edit a document, select it and click the **Edit** button, or double-click on the document name.

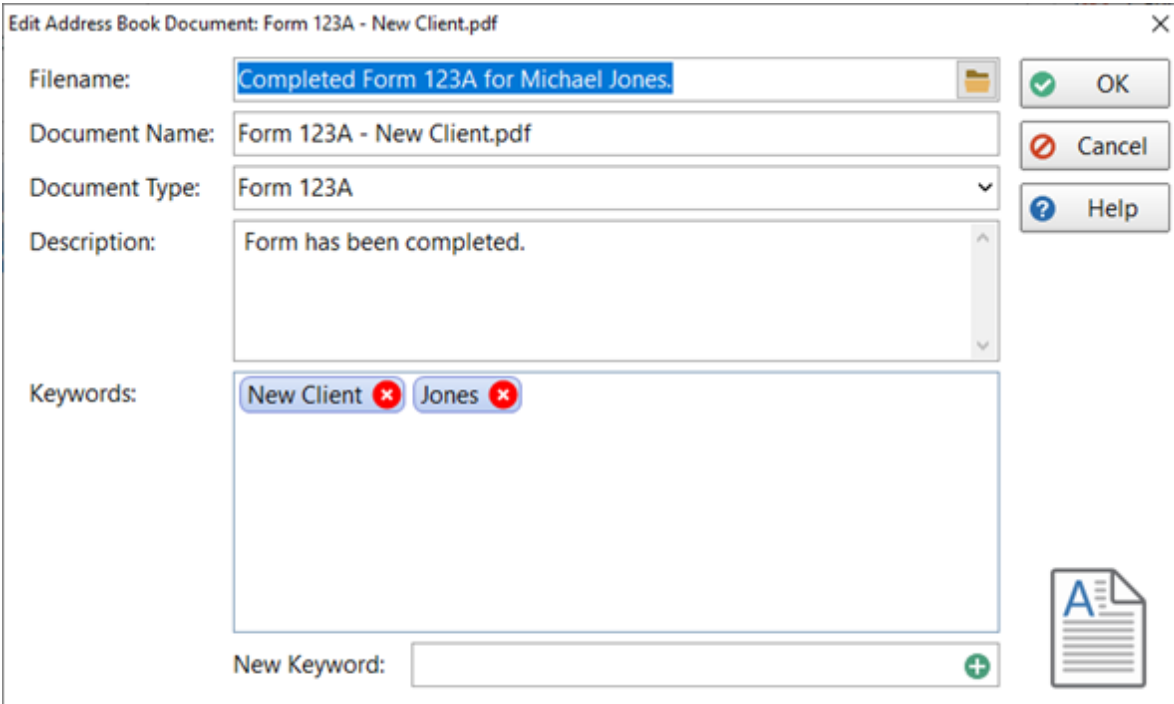

The screenshot shows a dialog box titled "Edit Address Book Document: Form 123A - New Client.pdf". It contains the following fields and controls:

- Filename:** A text field containing "Completed Form 123A for Michael Jones." with a folder icon to its right.
- Document Name:** A text field containing "Form 123A - New Client.pdf".
- Document Type:** A dropdown menu currently set to "Form 123A".
- Description:** A text area containing "Form has been completed." with scrollbars.
- Keywords:** A list of keywords: "New Client" and "Jones", each with a red 'x' button to its right for removal.
- New Keyword:** A text field with a green '+' button to its right for adding a new keyword.
- Buttons:** "OK" (with a green checkmark), "Cancel" (with a red 'x'), and "Help" (with a question mark) are located on the right side.
- Icon:** A document icon with a blue 'A' is located in the bottom right corner.

Editing a document is pretty much the same as adding a document. You can change the document file, the **Document Name**, **Document Type**, **Description** and **Keywords**.

Deleting a Document

To delete a document, select the document and click the **Delete** button.

You will be asked to confirm the deletion.

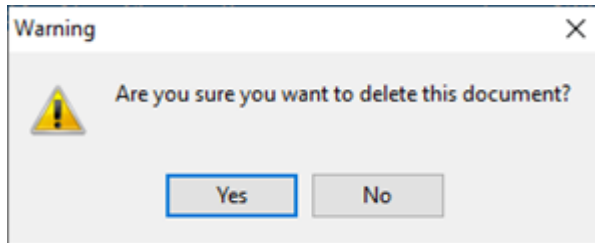

Opening a Document

You can open a document by selecting it from the list and clicking the **Open** button.

Saving a Document

If you need an external copy of a document, select the document and click the **Save** button.

You will be prompted to select the location to save the file.

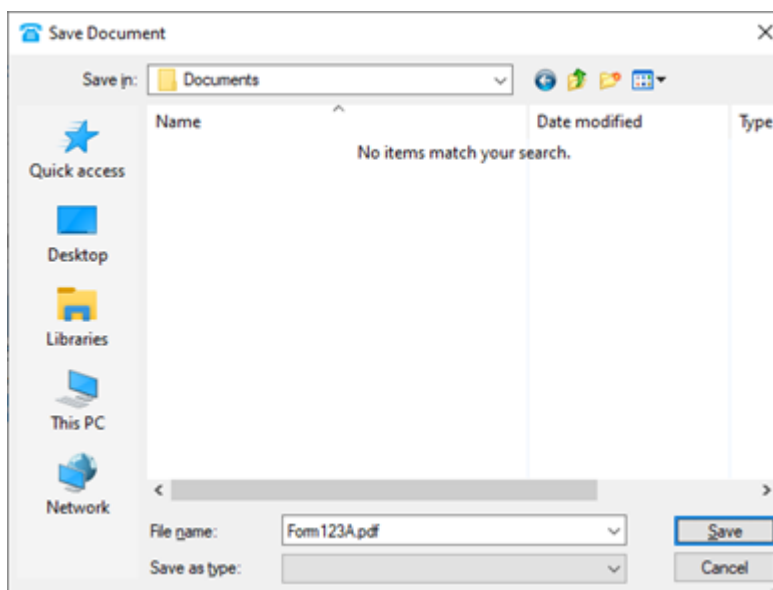

Searching for Documents

The **Document** tab in the **Address Book** provides an easy way to find documents for the selected Caller (Address Book entry).

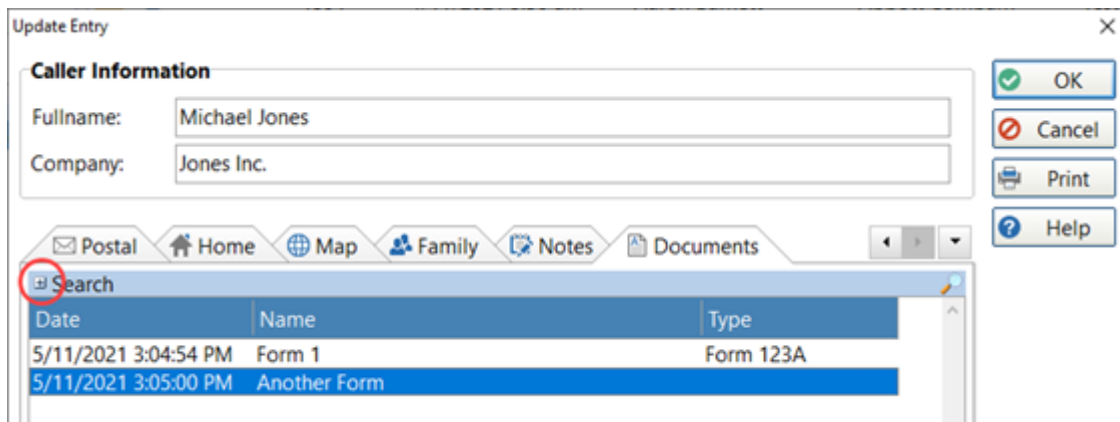

1. If the Search panel is closed, click on the + button to open the panel.
2. Select a keyword from the **Keywords** list.
3. Click the **Search** button.

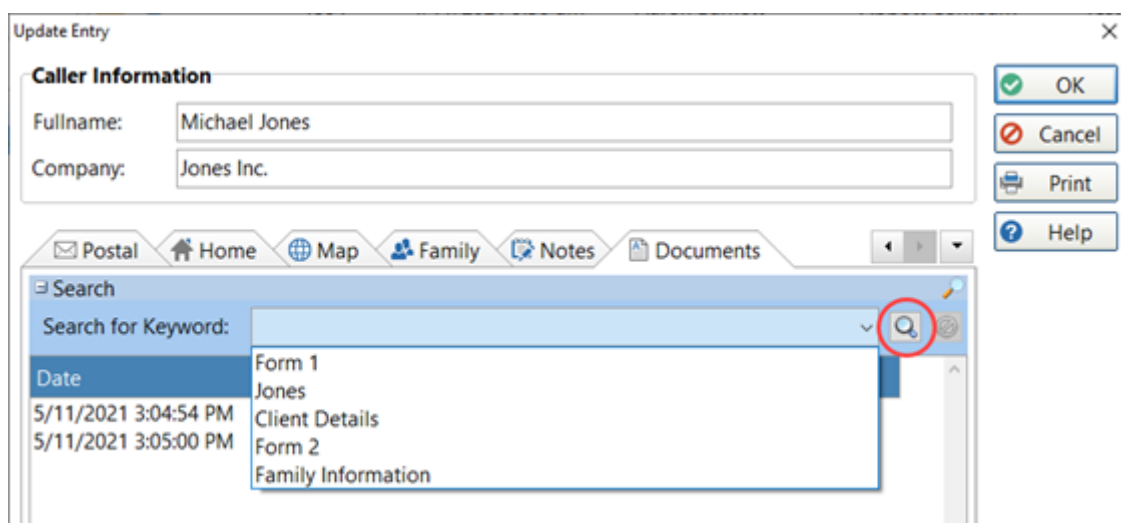

4. The document list will display all documents that have that keyword.

To clear the search results, click the **Cancel Search** button.

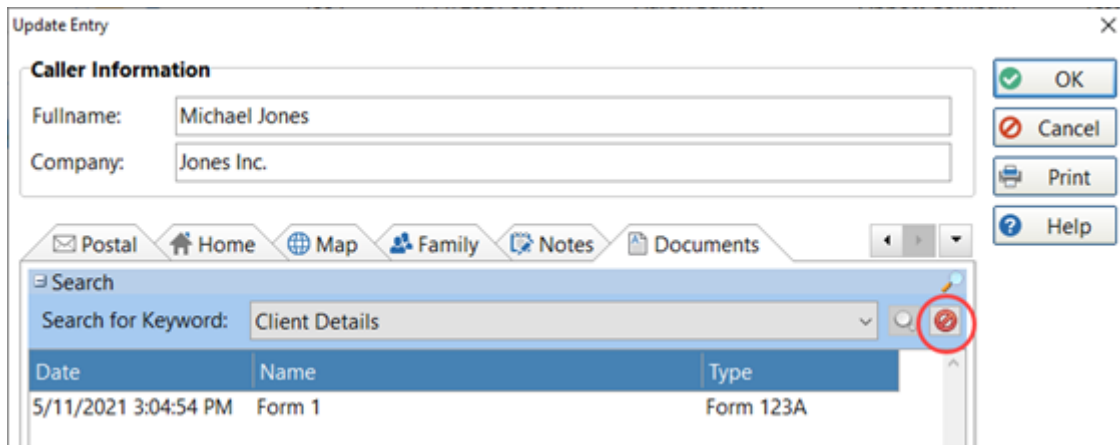

Close the Address Book

To close the Address Book click the **Close** button.

Chapter

13

System Information

System Information

The System Information windows displays information that can be useful for support staff trying to diagnose an issue.

Select **System Information** from the **Help** menu.

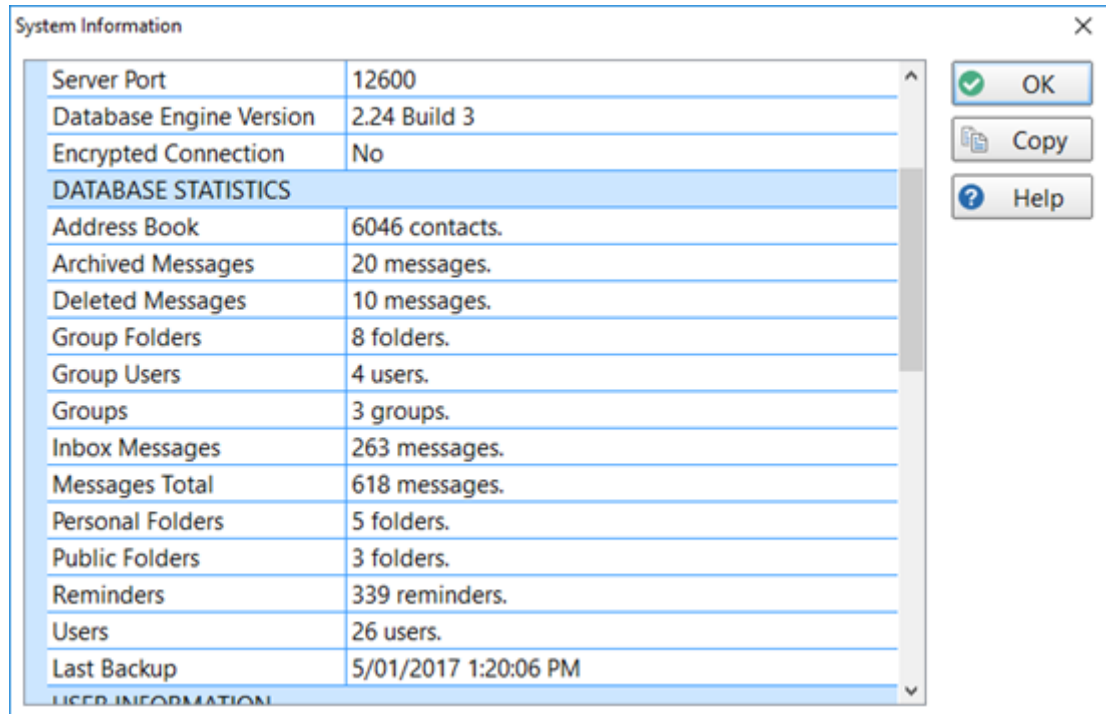

You can click the **Copy** button to copy these details to the Windows clipboard.

System Information displays:

- Application information
- Database information
- Database Statistics
- User Information
- License Details
- System information
- Anti-virus, anti-spyware and firewall software details

Chapter

14

Control Bar

Control Bar

The **Control Bar** is a toolbar that appears on your desktop and can be displayed anywhere on the screen. It will be displayed even when PhonePad is minimized.

The **Control Bar** gives you quick and easy access to common PhonePad 5 functions while leaving PhonePad minimized.



It features 12 buttons that allow you to access these features:

Inbox Opens PhonePad and displays your Inbox. It also shows the number of unread messages.

Phone Message Opens a new phone message.

Outgoing Message Opens a new outgoing message.

Text Message Opens a new text message.

Reminders Opens the Manage Reminders screen. It also shows the number of due reminders.

Appointment Calendar Opens the Appointment Calendar.

Address Book Opens the PhonePad Address Book.

Instant Chat Opens Instant Chat.

To Do List Opens the To Do List.

WhereRU Opens the WhereRU application.

Settings Opens the Settings window.

Exit Closes ControlBar.

When hovering the mouse over Control Bar buttons, the buttons will show a hint revealing the name of the button.



Control Bar Settings

Click the **Settings** button to open the **Settings** window. You can set **Control Bar** to only show the buttons you want to see.

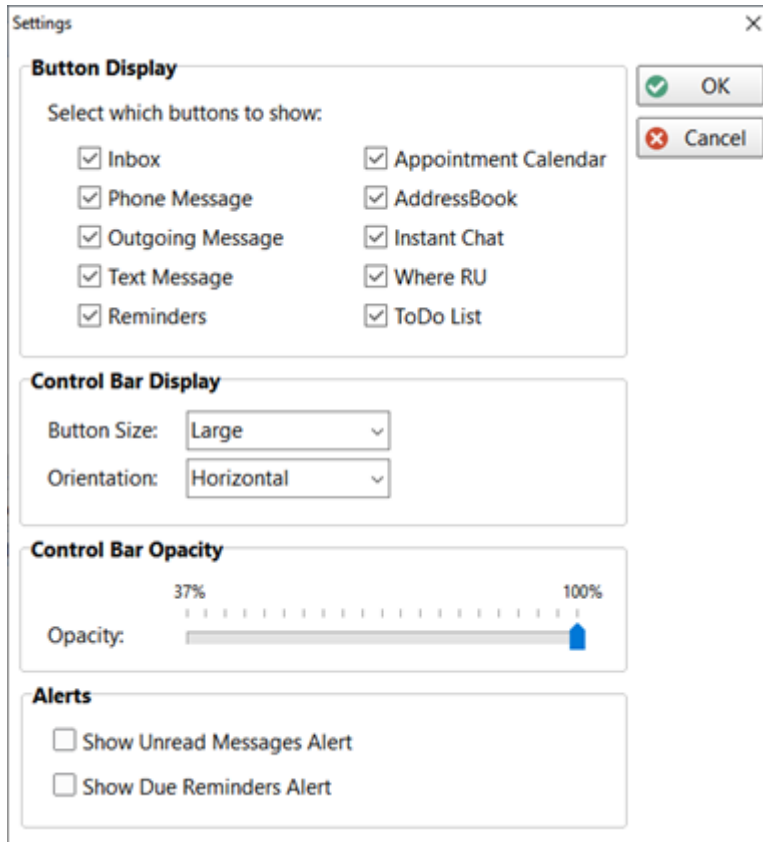

Button Display	
Inbox	When checked, the Inbox button will be displayed on the Control Bar.
Phone Message	When checked, the Incoming Phone Message button will be displayed on the Control Bar.
Outgoing Message	When checked, the Outgoing Phone Message button will be displayed on the Control Bar.
Text Message	When checked, the Text Message button will be displayed on the Control Bar.
Reminders	When checked, the Reminders button will be displayed on the Control Bar.
Appointment Calendar	When checked, the Appointment Calendar button will be displayed on the Control Bar.

Address Book	When checked, the Address Book button will be displayed on the Control Bar.
Instant Chat	When checked, the Instant Chat button will be displayed on the Control Bar.
WhereRU	When checked, the WhereRU button will be displayed on the Control Bar.

Control Bar Display	
Button Size	You can choose the size of the Control Bar buttons: Small, Medium, Large or Larger .
Orientation	You can set the orientation to Horizontal or Vertical .

Control Bar Opacity	
Opacity	This control allows you to set the transparency of the Control Bar. When you change the Opacity you can see the change immediately. When you click the OK button, the change will be applied to the Control Bar.

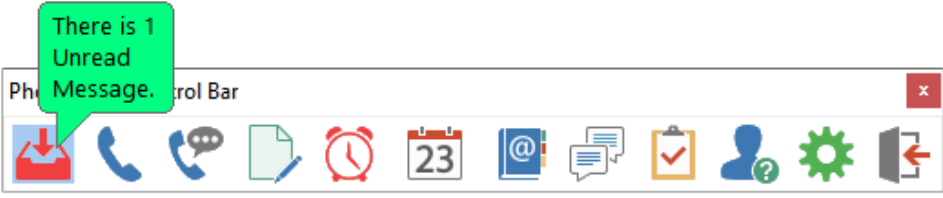
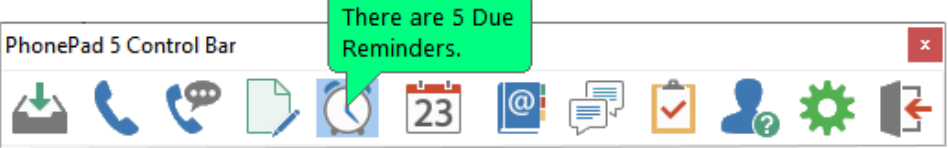

Alerts	
Show Unread Messages Alert	When checked, the Inbox button will show the number of Unread Messages in the button hint (it will be green rather than yellow). The button will also flash.

	 <p>There is 1 Unread Message.</p> <p>PhonePad Control Bar</p> <p>The screenshot shows a control bar with a title 'PhonePad Control Bar' and a close button. The bar contains several icons: a red download icon, a blue phone icon, a blue speech bubble icon, a green document icon, a red alarm clock icon, a calendar icon showing '23', a blue '@' icon, a blue speech bubble icon, a yellow checkmark icon, a blue person icon with a question mark, a green gear icon, and a grey arrow icon pointing left.</p>
Show Due Reminders Alert	<p>When checked, the Reminders button will show the number of Due Reminders in the button hint (it will be green rather than yellow). The button will also flash.</p>  <p>There are 5 Due Reminders.</p> <p>PhonePad 5 Control Bar</p> <p>The screenshot shows a control bar with a title 'PhonePad 5 Control Bar' and a close button. The bar contains several icons: a green download icon, a blue phone icon, a blue speech bubble icon, a green document icon, a blue clock icon, a calendar icon showing '23', a blue '@' icon, a blue speech bubble icon, a yellow checkmark icon, a blue person icon with a question mark, a green gear icon, and a grey arrow icon pointing left.</p>

Launching ControlBar

To launch the Control Bar, select **Control Bar** from the **Tools** menu.

You can set the Control Bar to start automatically when PhonePad starts by checking the **Launch Control Bar when PhonePad starts** check box under **Settings/Preferences/General**.

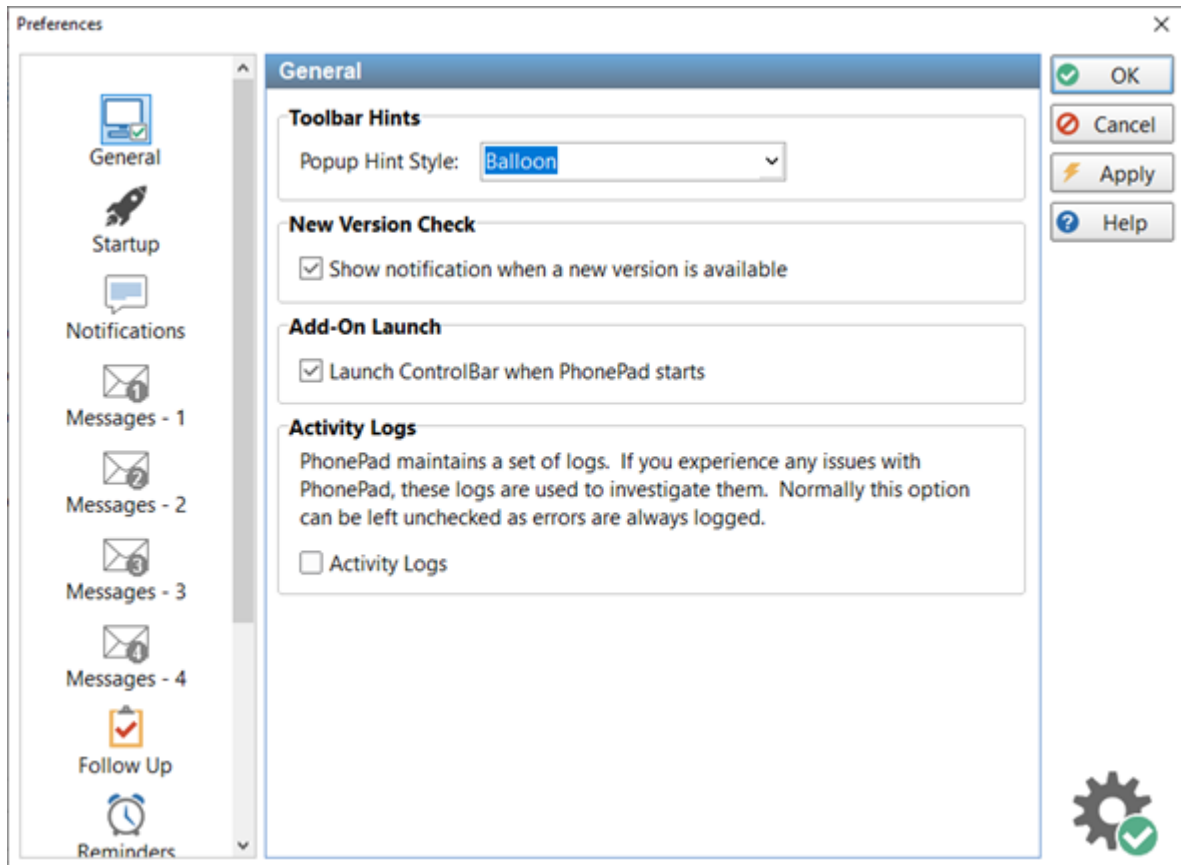

Chapter

15

Shortcuts

Shortcuts

To make it quicker and easier to access some features in PhonePad, a number of shortcuts are available.

Main Screen

New Phone Message	<shift> <insert>
New Outgoing Message	<ctrl> <insert>
New Text Message	<alt> <insert>
Delete Selected Message	<delete>
View Selected Message	<enter>
View Address Book	<F4>
Check Inbox	<F5>
Refresh Inbox	<shift> <F5>
Refresh User List	<F6>
Exit PhonePad	<ctrl> <alt> <x>

Phone Message Form

To	<F2>
Date	<F3>
Time	<F4>
Caller	<F5>
Phone	<F6>
Company	<F7>
Category	<F8>
Subject	<F9>
Reference	<F11>
Message	<F12>
Email	<shift> <F7>
Custom	<shift> <F8>
Date of Birth	<shift> <F9>

Chapter

16

Instant Chat

Instant Chat

PhonePad 5 includes a simple, easy-to-use instant messaging application designed to operate within your network.

To open Instant Chat, click the **Instant Chat** button on the **Home** tab of the toolbar, or select **Instant Chat** from the **Tools** menu, or click the **Instant Chat** icon on the status bar.



Starting a Chat

When Instant Chat starts you will be presented with the *Users* screen.

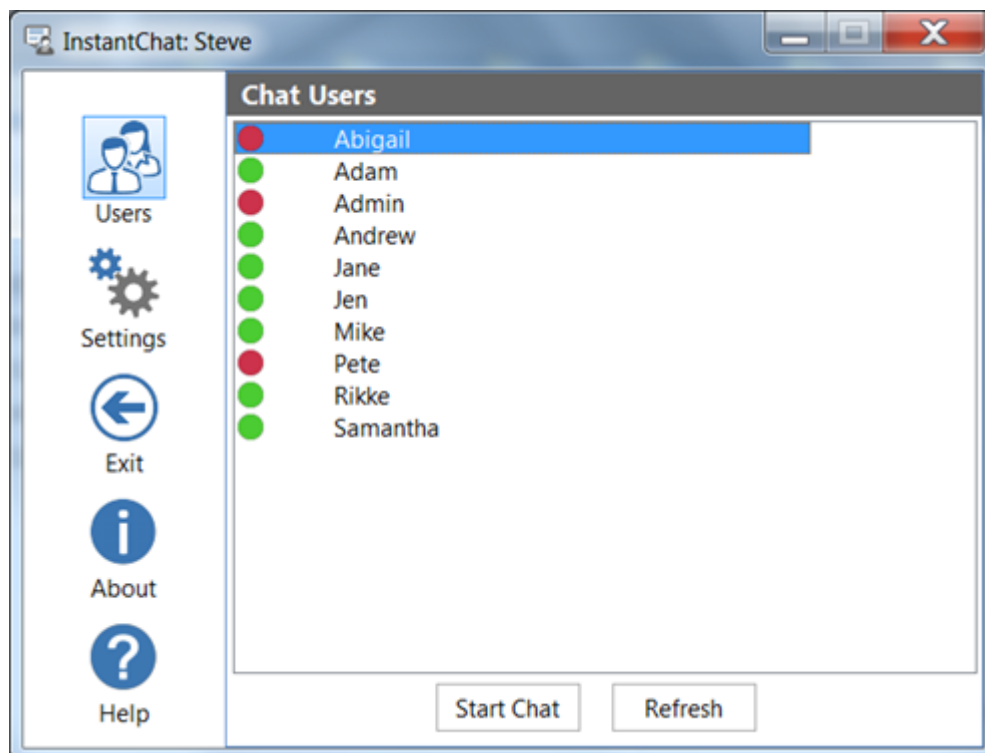

A **green** status indicator means the user has Instant Chat running and is available. A **red** status indicator means the user does not have Instant Chat running and is not available.

To start chatting with someone, select their name from the list and click **Start Chat**. The chat window will appear in the bottom right corner of your screen.

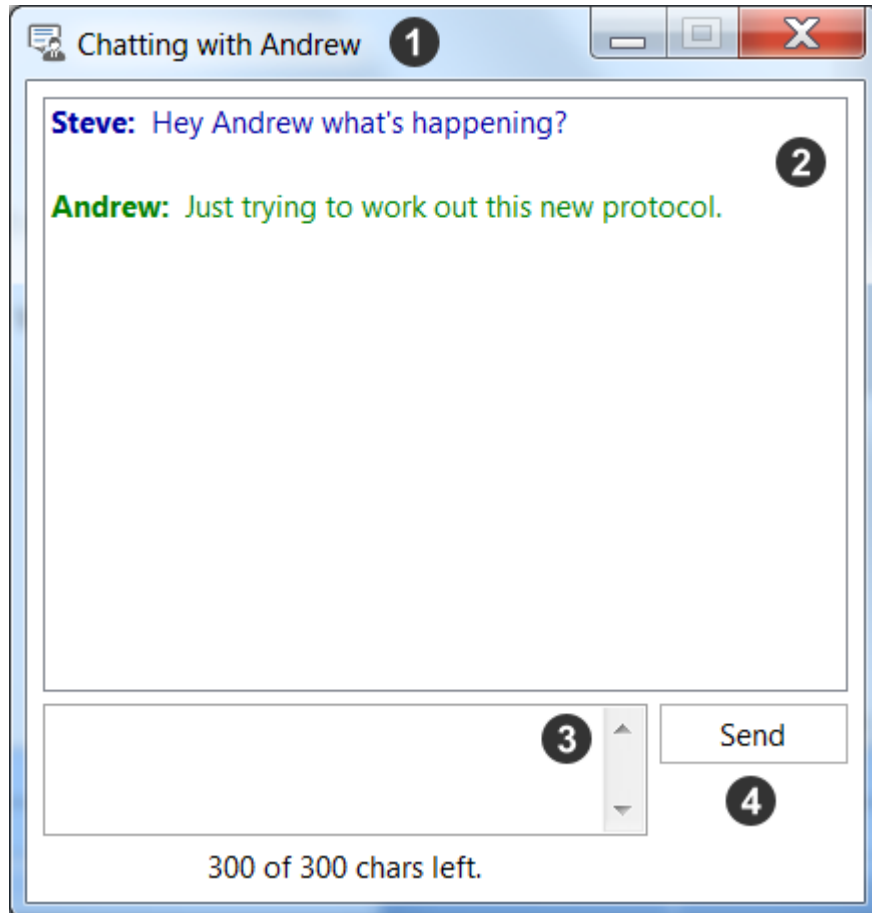

1	The title bar of the chat window shows who you are chatting with.
2	This is the conversation area where all of the chat text appears. The text you send will be blue and the text you receive will be green.
3	This is where you enter the text you want to send to the other person.
4	Click Send to send your text, or just press the <enter> key.

Although you can only chat to one person in the chat window, you can have multiple chat windows open at the same so you can chat with as many people as you like individually.

Receiving a New Chat

When someone else initiates a chat with you, a new chat window will open and a popup notification will be displayed.

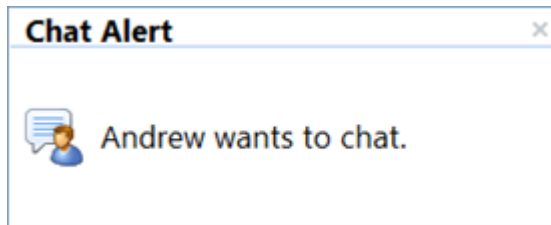

Ending a Chat

To finish a chat just close the chat window. You will be asked to confirm this (unless you have disabled this option).

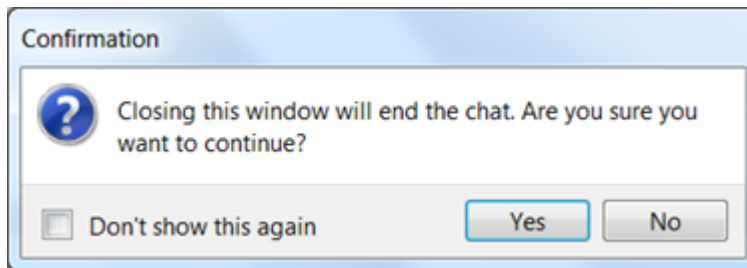

Click **Yes** to close the chat or click **No** to continue the chat. If you don't want these confirmation messages again check the **Don't show this again** check box before clicking **Yes** or **No**.

If the other person closes the chat window before you, you will receive a notification message from the system. System messages are always shown in black.

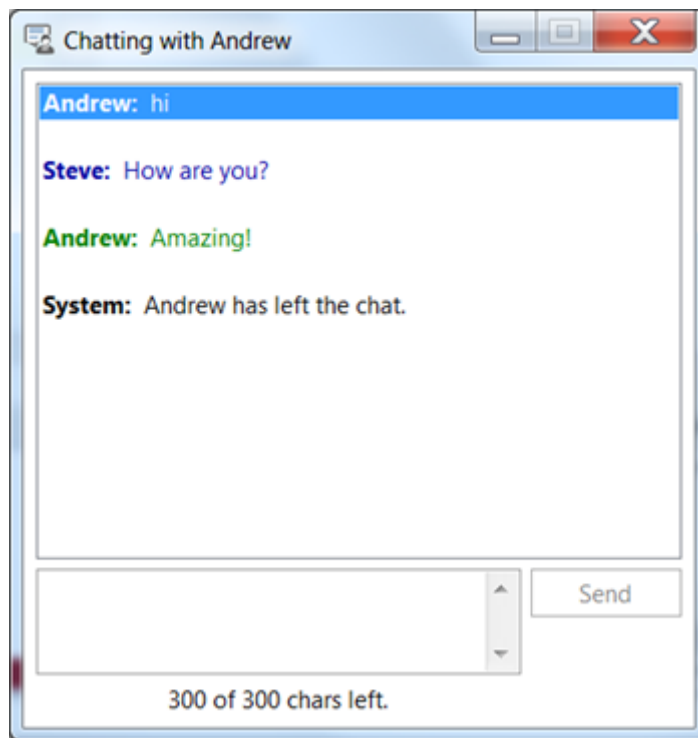

Once the other party has left the chat you will not be able to send any further text (so you don't end up talking to yourself).

Settings

Select **Settings** from the side menu to access the Instant Chat settings.

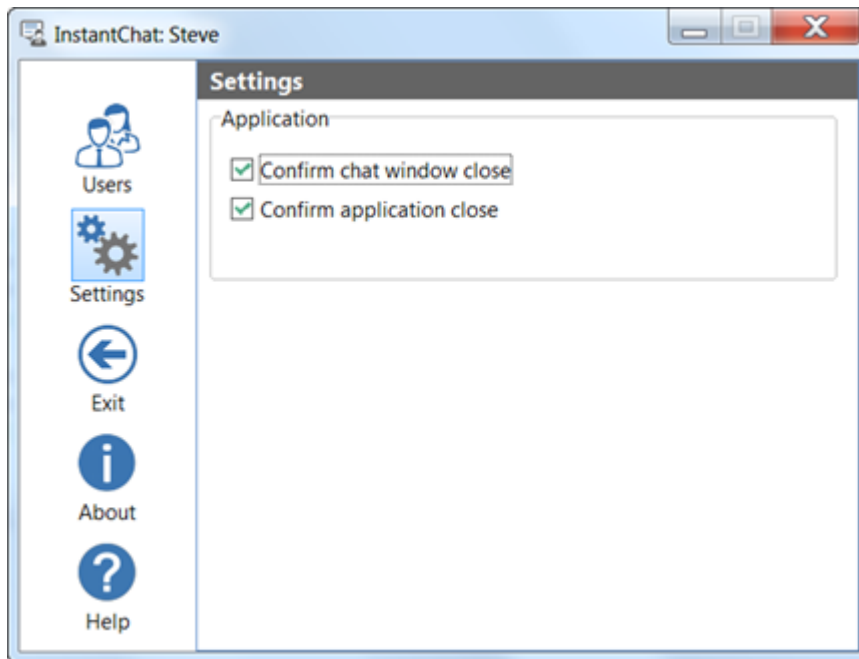

Confirm chat window close	When checked, you will be asked to confirm closing a chat window.
Confirm application close	When checked, you will be asked to confirm closing Instant Chat.

Closing Instant Chat

To close Instant Chat (rather than minimizing it), click the Exit button. You will be asked to confirm this (unless you have disabled this option).

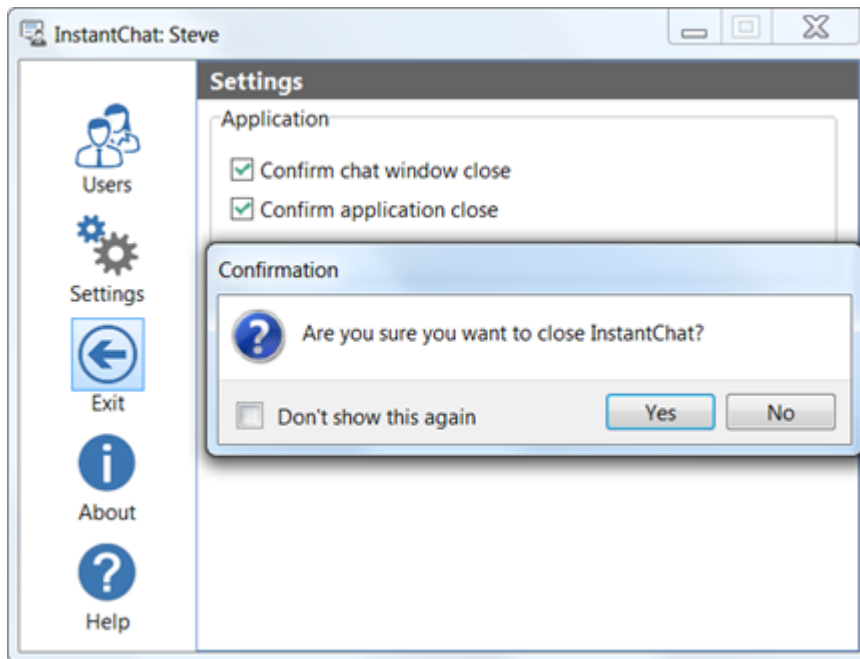

This page intentionally left blank.

Chapter

17

Message Alert

Message Alert

If you have access to multiple Inboxes then it can be awkward trying to monitor them all for new messages. That's where Message Alert comes in.

Message Alert will display a notification message above the system tray area each time one of the Inboxes you are monitoring receives a new message.

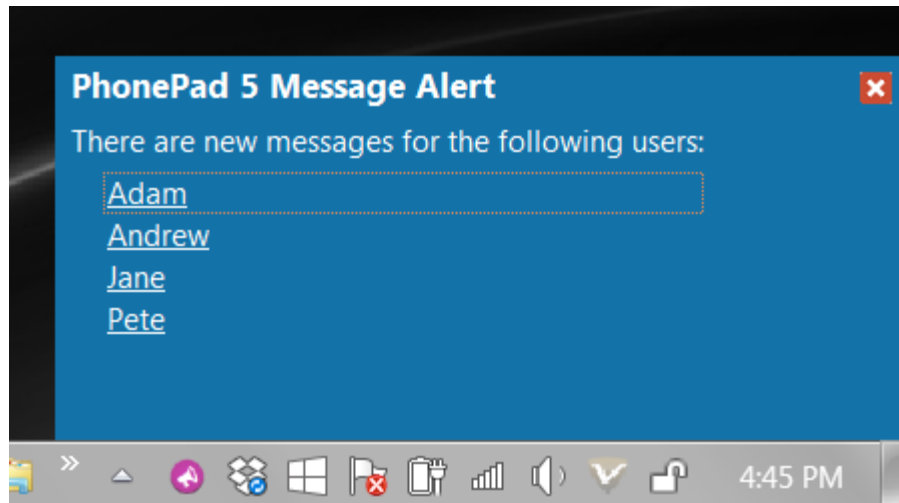

You can launch Message Alert by selecting **Message Alert** from the **Tools** menu. If you don't have access to other users' Inboxes then the option will be grayed out.

On start up Message Alert will minimize to the system tray/notification area.

Menu

Right-click on the Message Alert icon in the system tray/notification area to access the menu.

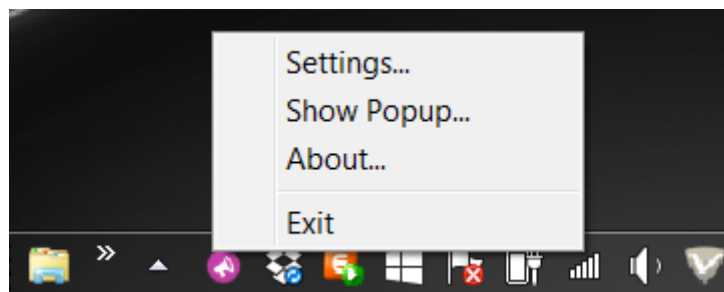

Settings	Opens the settings window.
Show Popup	Shows the popup notification window.
About	Displays information about MessageAlert, eg. Version Number.
Exit	Closes the application.

Setting Up Message Alert

Before you can start using Message Alert you will need to set it up:

1. Launch Message Alert by selecting **Message Alert** from the **Tools** menu.
2. Message Alert runs in the system tray/notification area of the Windows toolbar. When Message Alert starts it will minimize to that area.
3. Right-click on the purple Message Alert icon in the toolbar and select **Settings**.

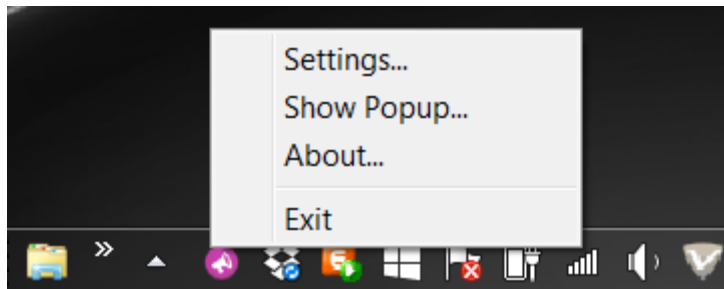

4. The Message Alert options window will open.

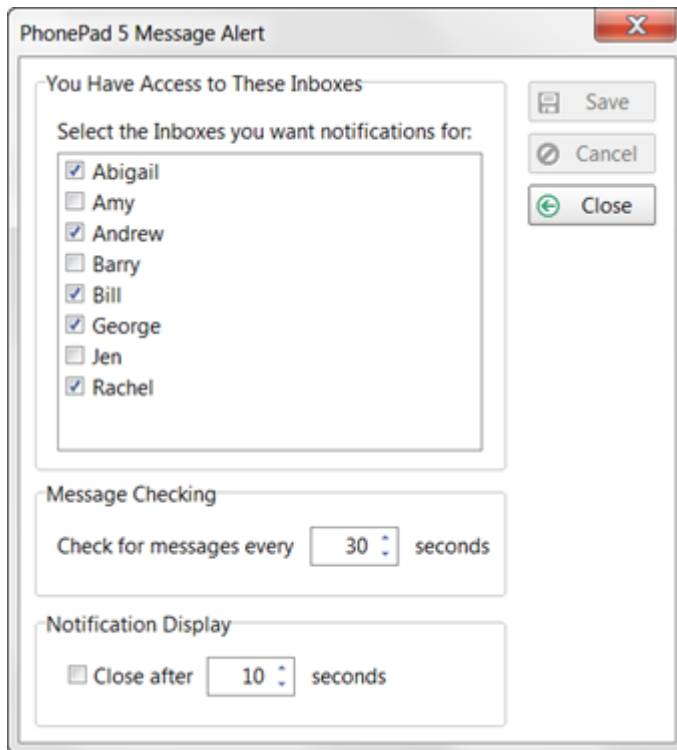

Select the Inboxes You Want to Monitor

This window displays a list of all Inboxes you have access to (your PhonePad Administrator sets this access).

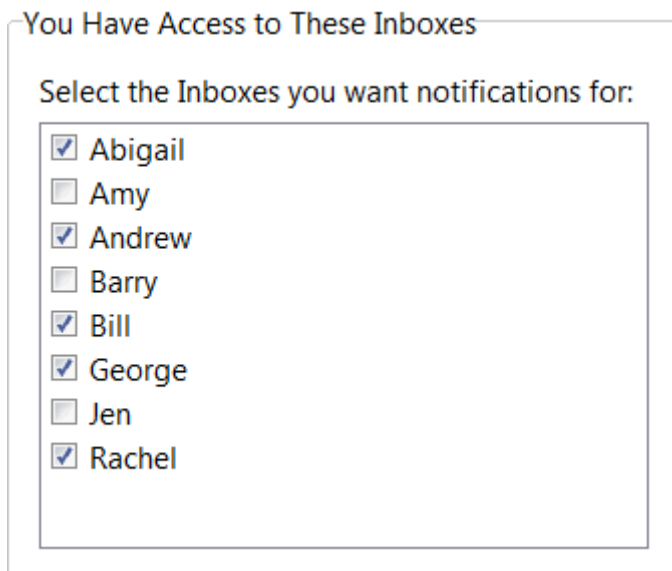

Select which Inboxes you want to receive new message notifications for by checking the check box next to each name

Set the Message Checking Frequency

Set how often you want Message Alert to check for new messages. The default is 30 seconds.

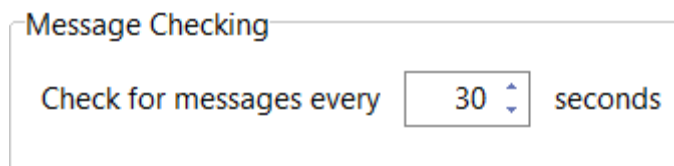

The screenshot shows a dialog box titled "Message Checking". Inside the dialog, there is a label "Check for messages every" followed by a spin box containing the number "30" and a small up/down arrow icon, and the word "seconds" to the right of the spin box.

Set the Notification Display

This setting determines how long the new message notification is displayed.

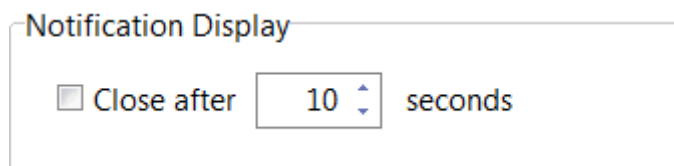

The screenshot shows a dialog box titled "Notification Display". Inside the dialog, there is a checkbox labeled "Close after" which is currently unchecked. To the right of the checkbox is a spin box containing the number "10" and a small up/down arrow icon, and the word "seconds" to the right of the spin box.

If you check the **Close after x seconds** check box, the message notification will automatically close after the specified number of seconds.

If you leave the **Close after x seconds** check box unchecked, the message notification window will stay open until you close it.

Save Your Settings

Click the **Save** button to save your settings, or click the **Cancel** button to cancel the changes.

Using Message Alert

When a new message is received in an Inbox you are monitoring, the user's name will appear in the Message Alert notification window.

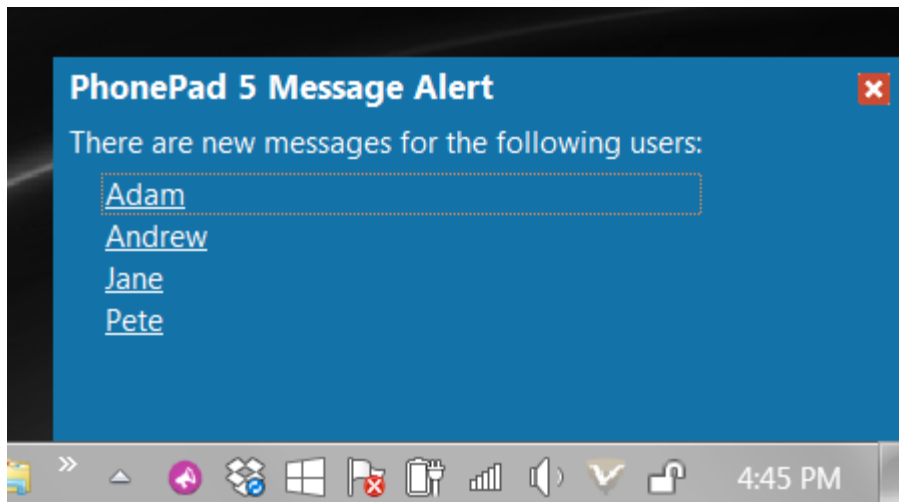

You can go directly to the Inbox for that user by clicking their name.

When new messages are read by a user their name will drop off the list.

Starting and Stopping Message Alert Automatically

You can either open and close Message Alert manually via the **Tools** menu, or you can set PhonePad to open and close it for you (see Preferences - Message Alert).

Chapter

18

ToDo List

ToDo List

The **ToDo List** add-on provides a "to-do" list style application that can be used to track tasks that you need to do. It complements the Follow Up features of PhonePad.

One of the main differences between PhonePad's ToDo List and other "to-do" lists integrates tightly with PhonePad.

To access the **ToDo List**, click on the **ToDo List** button on the **Follow Up** tab of the toolbar, or select **ToDo List** from the **Tools** menu.



Chapter

19

WhereRU

WhereRU

WhereRU provides a simple way for an organization to keep track of their staff. A quick glance at the screen tells you the availability of everyone in your office. Used in conjunction with PhonePad, you can pass on information to callers while taking a message for the person they called.

To open WhereRU, click the **WhereRU** button on the **Home** tab of the toolbar, or select **WhereRU** from the **Tools** menu.

User Interface

Main Window

The main window of WhereRU features a menu bar, a toolbar, a User Details pane, and a status bar. There is a splitter between the user list and the User Details pane that can be resized, opened or closed.

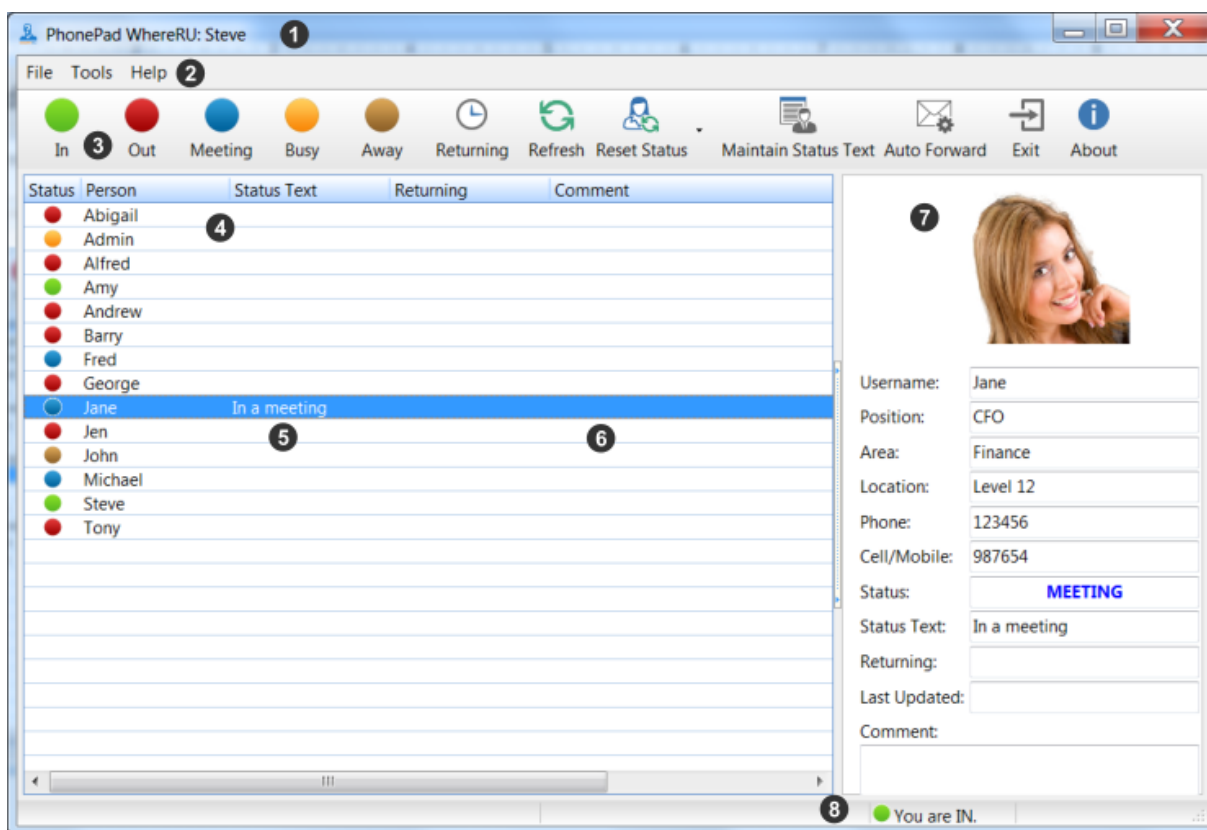

1	The title bar shows the name of the user logged in.
2	Menu bar.
3	Toolbar.
4	User list.
5	Status text field, which can be edited directly in the list.
6	Comments field, which can be edited directly in the list.
7	User information panel.
8	Your status.

Toolbar

WhereRU has its own toolbar.

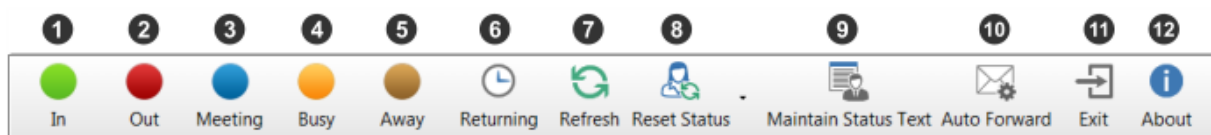

1	Change your status to IN.
2	Change your status to OUT.
3	Change your status to MEETING.
4	Change your status to BUSY.
5	Change your status to AWAY.
6	Set the time you will return.
7	Refresh the user list.
8	Reset your status.
9	Maintain status text used by all users. Only accessible to administrators.
10	Set your <i>Automatic Message Forwarding</i> settings. Administrators can also change these settings for other users.

11	Close WhereRU.
12	Display information about WhereRU.

Menus

File Menu

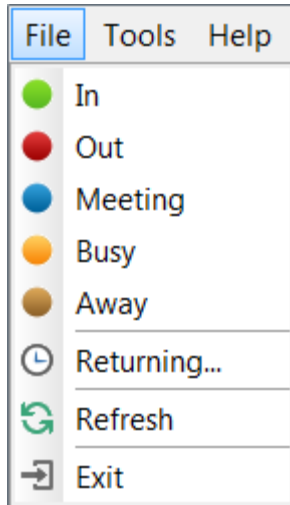

In	Change your status to IN.
Out	Change your status to OUT.
Meeting	Change your status to MEETING.
Busy	Change your status to BUSY.
Away	Change your status to AWAY.
Returning	Set the time you will return.
Refresh	Refresh the user list.
Exit	Close WhereRU.

Tools Menu

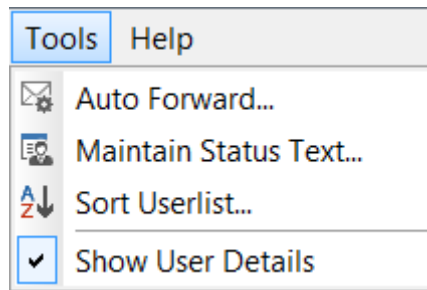

Auto Forward	Set your <i>Automatic Message Forwarding</i> settings. Administrators can also change these settings for other users.
Maintain Status Text	Maintain status text used by all users. Only accessible to administrators.
Sort Userlist	Used to specify the order of users displayed in the user list. Only accessible to administrators.
Show User Details	When checked, the <i>User Details</i> panel will be visible.

Help Menu

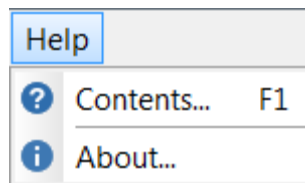

Contents	Display help.
About	Display information about WhereRU.

Setting Your Status

Setting your current status is easy. Just select your name in the list of users and click the appropriate status button (*In, Out, Meeting, Busy* or *Away*).

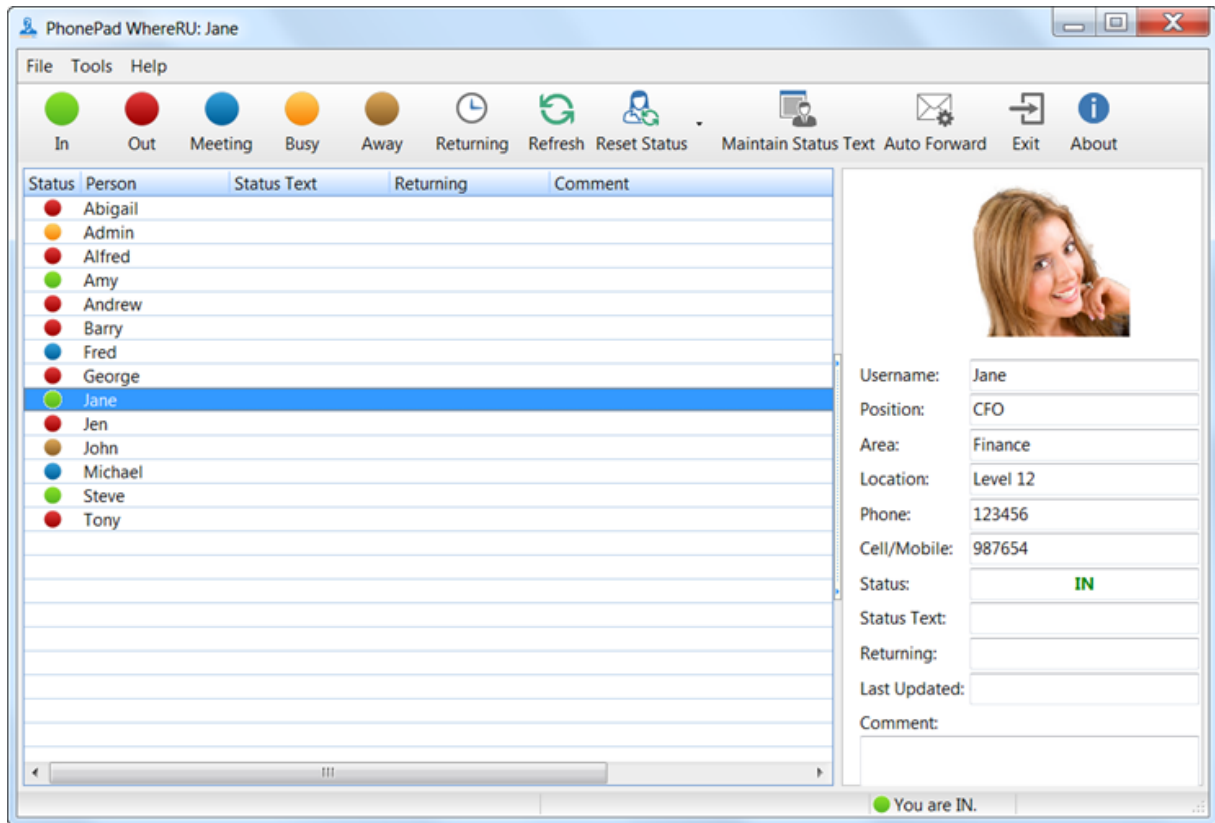

Setting a Return Time



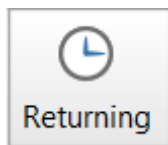

You can specify the time you expect to return. Select your name in the list, then click the **Returning** button on the toolbar, or select **Returning** from the **File** menu.

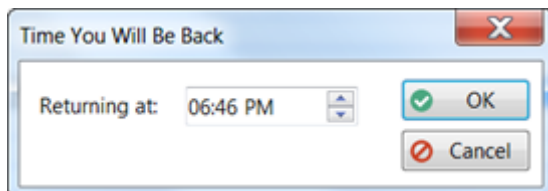

The *Time You Will Be Back* window will be displayed.



You can edit the time directly, or you can use the up and down arrows keys on your keyboard to change the hour, minutes and am/pm. You can also use the up and down arrow buttons of the **Returning at** field. Click **OK** when you have entered a time.

 Fred	
 George	
 Jane	6:46 PM
 Jen	
 John	

The time will be displayed next to your name in the user list.

Clearing a Return Time

To clear the return time, right-click on your name and select **Clear Return Time** from the popup menu.

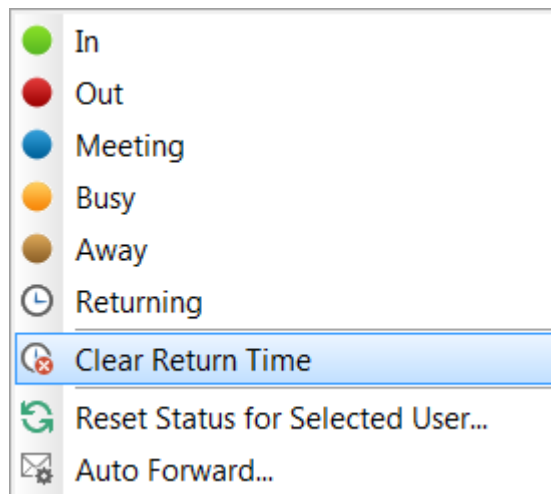

Setting Status Text

Pre-defined status text can be added to your status (or another user's status if you're an administrator) by clicking in the *Status Text* column and selecting from the drop-down list.

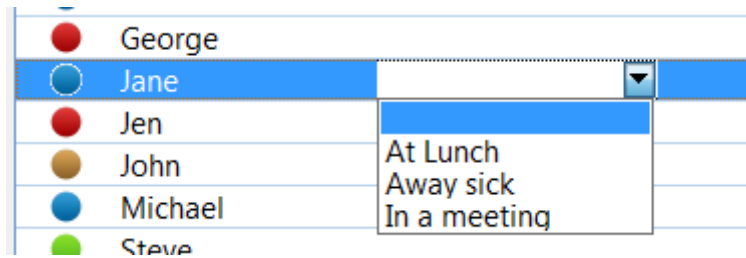

Comments

Comments can be entered directly in the user list against your name by clicking in the *Comments* column typing in a comment.

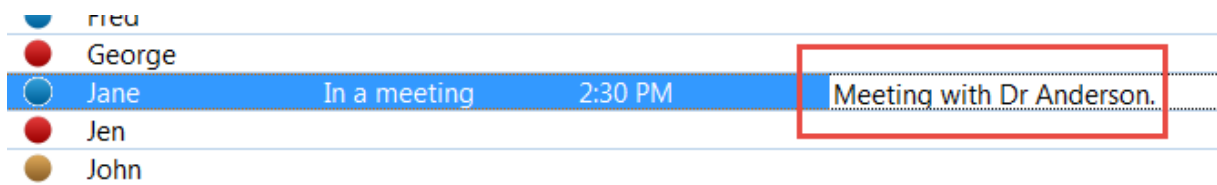

Resetting Your Status

You can reset your status by selecting your name and then clicking the **Reset Status** button on the toolbar and selecting **Reset Status for Selected User** from the menu.

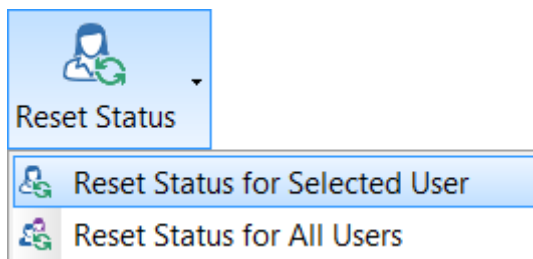

Administrators can reset other users' statuses by using the same option. They can also reset the status of all users at once by clicking the **Reset Status** button on the toolbar and selecting **Reset Status for All Users** from the menu.

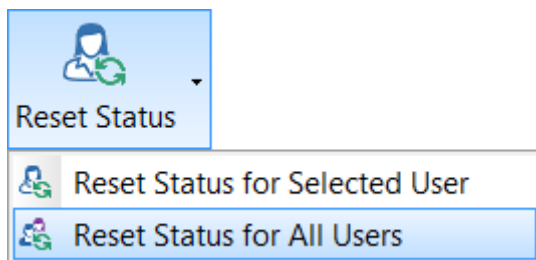

User Details

When a user is selected in the user list, their details will be displayed in the *User Details* panel on the right side of the main window.



Username:	Jane
Position:	CFO
Area:	Finance
Location:	Level 12
Phone:	123456
Cell/Mobile:	987654
Status:	MEETING
Status Text:	In a meeting
Returning:	2:30 PM
Last Updated:	
Comment:	Meeting with Dr Anderson.

Maintain Status Text

If you are an administrator you can maintain the status text that is used in WhereRU. Click the **Maintain Status Text** button on the toolbar, or select **Maintain Status Text** from the **Tools** menu.

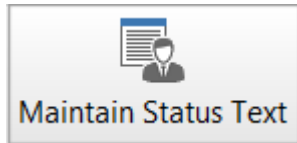

Use the **Add**, **Edit** and **Delete** keys to manage the status text, then click **OK** to save your changes.

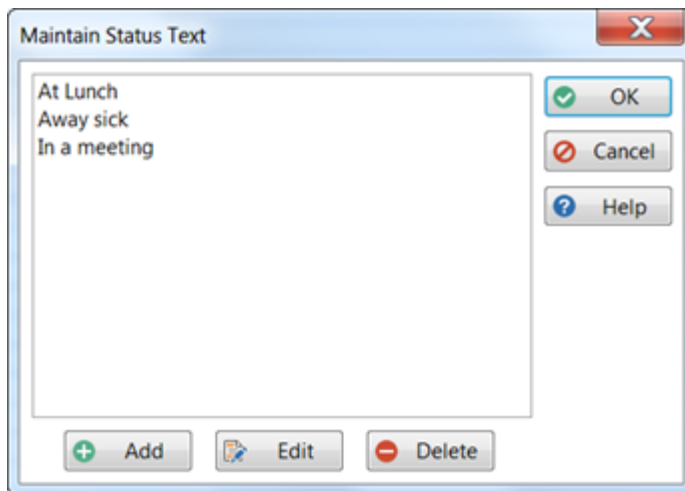

Sorting the User List

The user list in WhereRU defaults to alphabetical order. If you are an administrator you can manually change this order. Select **Sort Userlist** from the **Tools** menu.

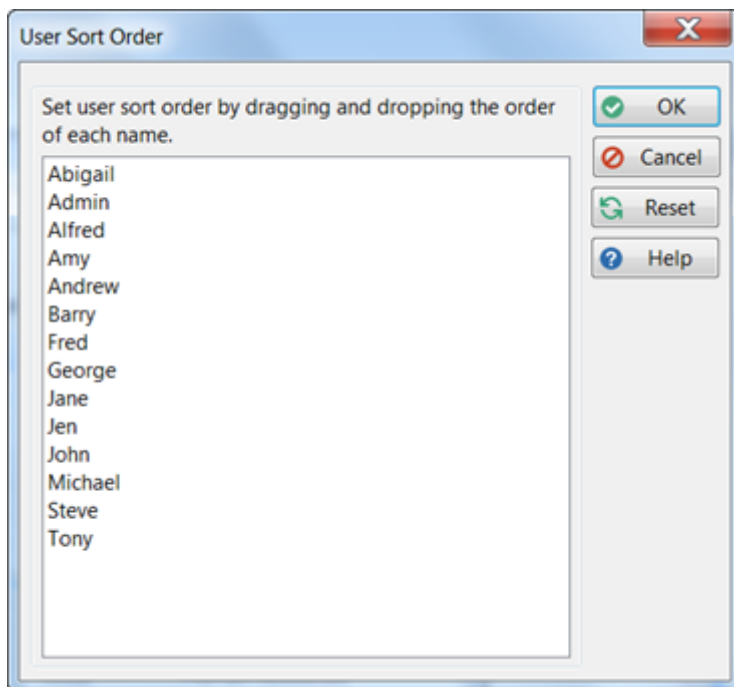

Order the usernames and by dragging and dropping them. Click **OK** to save your changes.

You can reset the list back to the default order by clicking the **Reset** button.

Automatic Message Forwarding

You can change your *Automatic Message Forwarding* settings (you can also do this in PhonePad) by clicking the **Auto Forward** button on the toolbar, or by selecting **Auto Forward** from the **Tools** menu.



If you are an administrator you can change these settings for other users.

This page intentionally left blank.

Chapter

20

WorkstationConfig

WorkstationConfig

The WorkstationConfig program is used to correct any issues you may have with PhonePad 5 Workstation.

It has 4 tabs:

- Server Auto Discovery
- Settings
- Comms
- Support

Server Auto Discovery

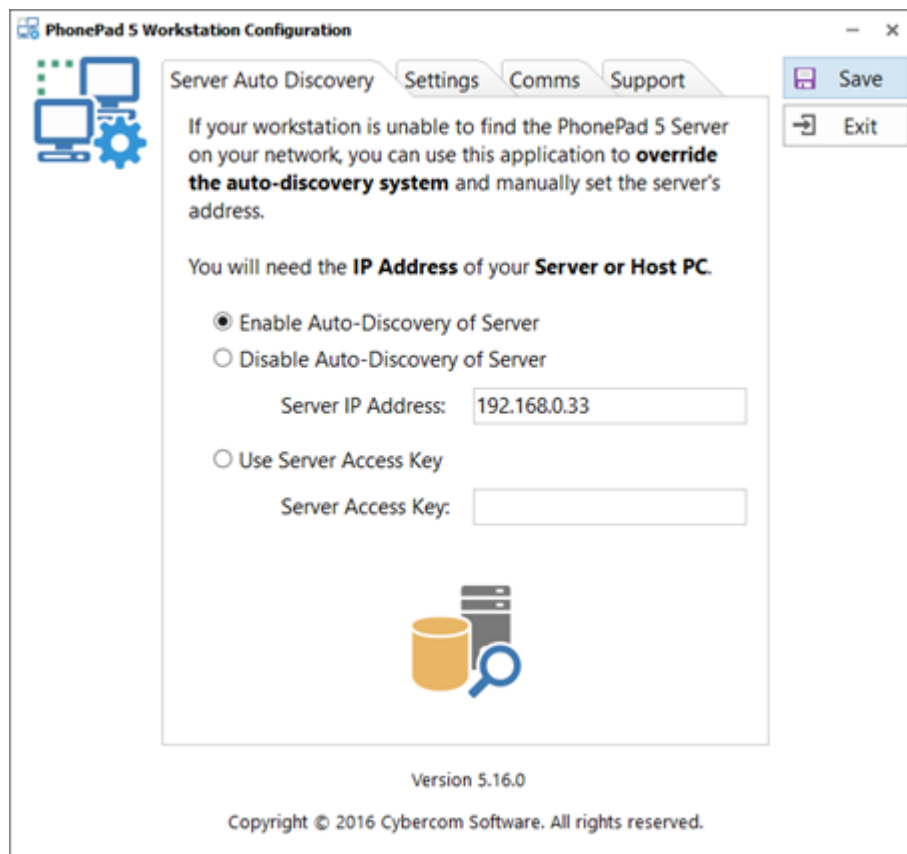

These settings are used to override the server auto-discovery system. You would use this in the following circumstances:

- UDP broadcasts are blocked on your network and so PhonePad is unable to find a server.
- You have a Wide Area Network.
- You have more than one PhonePad Server on your network.

Enable Auto-Discovery of Server

This is the default setting. PhonePad will try to locate a PhonePad Server on your network and establish a connection.

Disable Auto-Discovery of Server

If PhonePad is unable to locate a PhonePad Server on your network, and you have checked to make sure the server is running, then you may need to turn Auto-Discovery off and specify the IP Address of the Server.

There is a downside to using this method. If the Server's IP Address changes then the IP Address you entered here will no longer be valid. This means you will have connection problems again until you enter the Server's new IP Address.

If the Server's IP Address is likely to change, you are better off using the Server Access Key option instead of just disabling Auto-Discovery.

Use Server Access Key

This option also disables Auto-Discovery. Instead of specifying the Server's IP Address, it uses a Server Access Key to find out the Server's IP Address.

The way this works is that your PhonePad Administrator creates a Server Access Key on the Server using Control Center. They then give you this Access Key to enter under Server Access Key. Your PhonePad Server will regularly contact the Server Access Key system on our web server, updating its IP Address. When you start PhonePad it uses the Server Access Key to retrieve the Server's IP Address from the Server Access Key system using the Server Access Key.

In order for this to work, PhonePad needs to be able to access our web server via the Internet.

Settings

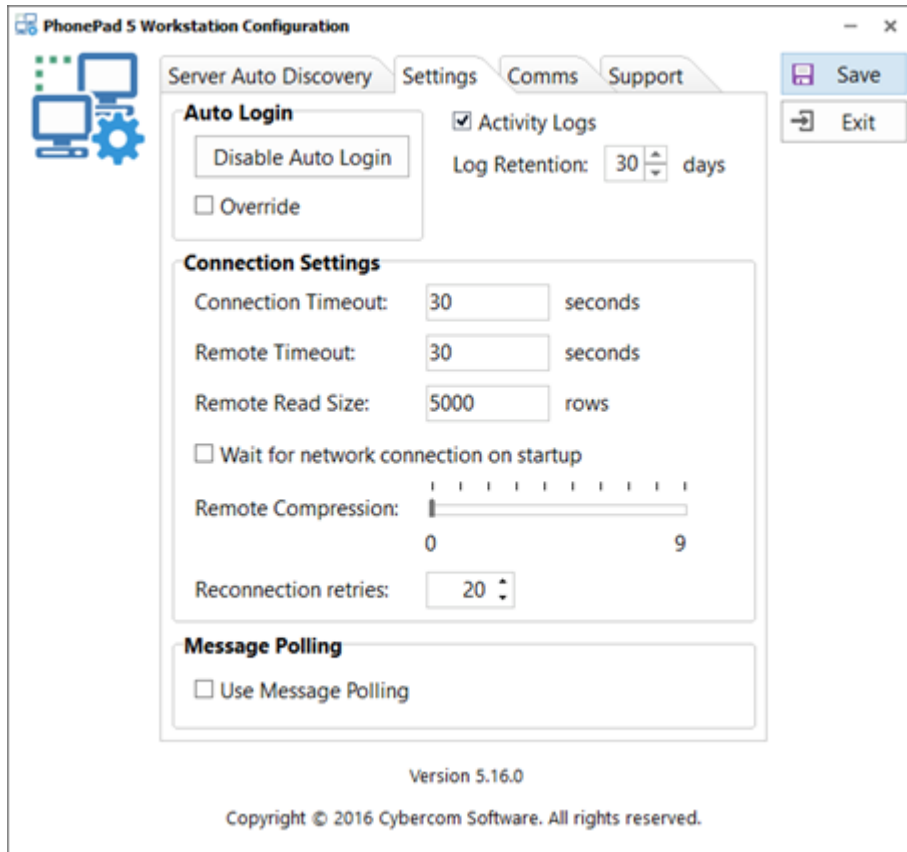

Disable Auto Login	Click this button to disable Auto Login for the logged in user.
Override	When checked, Auto Login is disabled.
Activity Logs	When checked, the workstation will produce activity logs. It is recommended you leave this option checked.
Log Retention	Specifies the number of days logs will be kept for. Any logs older than the set period will be automatically deleted. The default is 30 days.
Connection Timeout	Specifies how long PhonePad will wait to establish a connection.

Remote Timeout	Specifies how long PhonePad waits for a response from the server after a connection has been established.
Remote Read Size	Specifies how much data should be read for each data request.
Wait for Network Connection on Startup	When checked, PhonePad will wait for a network connection to become available before attempting to connect to the server.
Remote Compression	Determines whether or not data exchanged between the workstation and server is compressed or not, and the level of compress used. The default is 0.
Reconnection Retries	Specifies the number of times PhonePad should try to establish a connection with the server when the connection times out on initial connection.
Use Message Polling	When checked, PhonePad will poll the server checking for new messages. This option will override the Message Notification Service and can adversely affect performance.

Comms

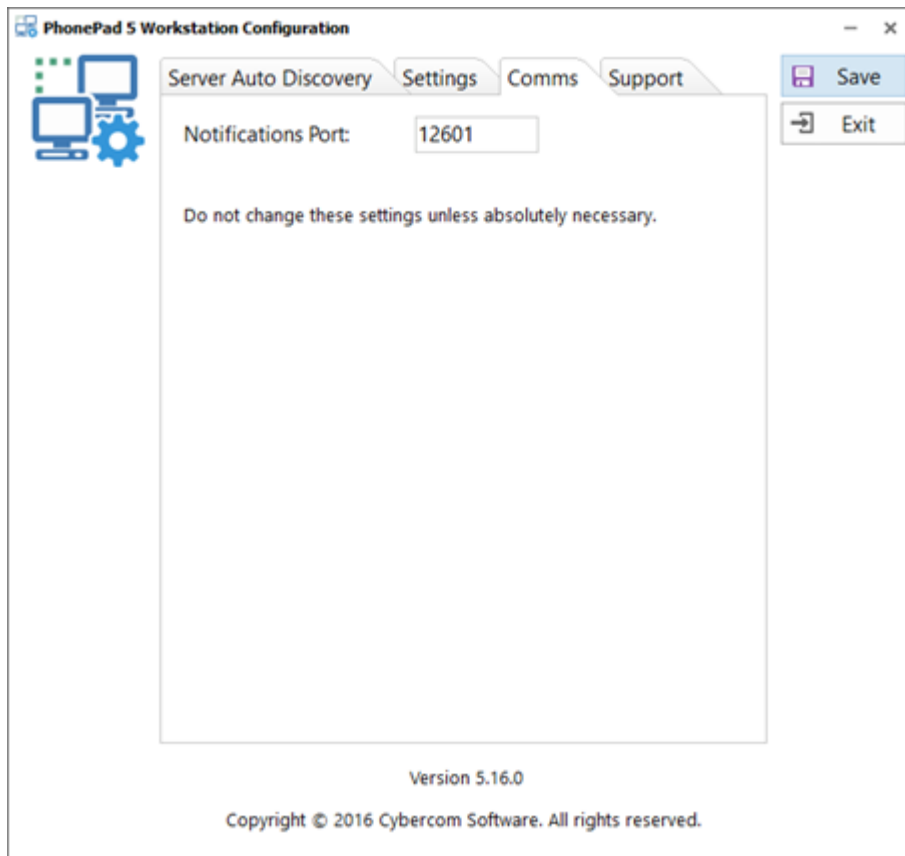

Notifications Port	This is the port used by PhonePad for notifications sent from the server. The default is 12601 and it should be left at this value.
---------------------------	---

Support

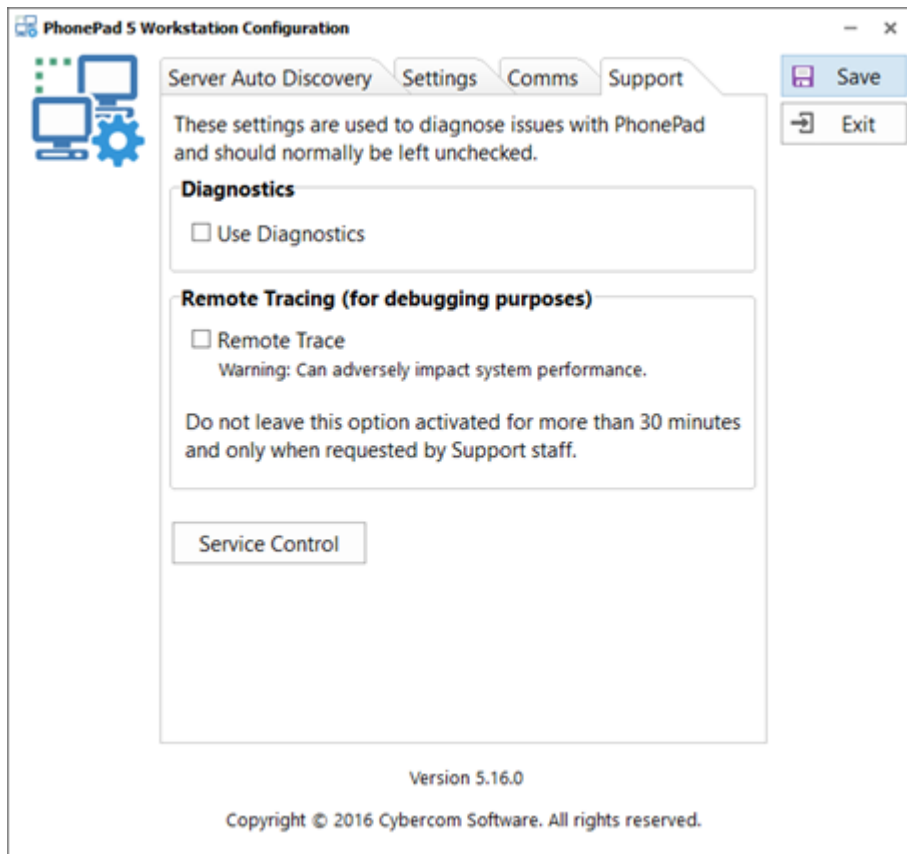

<p>Use Diagnostics</p>	<p>When checked, the workstation will add detailed information to activity logs. It is recommended you leave this option unchecked unless asked to turn it on by Support.</p>
<p>Remote Trace</p>	<p>This option is used to trace communication between a workstation and the server. It is strongly recommended you leave this option unchecked as it can severely impact application responsiveness and is only intended to be used for very short periods.</p>
<p>Service Control</p>	<p>Allows an administration to restart PhonePad services running on the Server or Host PC from any workstation.</p>

This page intentionally left blank.

Chapter

21

Workstation Service Center

Workstation Service Center

This application is used to control the PhonePad Windows services installed on a workstation. It is similar to the **Control Center** on the Server.

Currently there is only one PhonePad service running on workstations and you should normally never need to use this application.

To start **Workstation Service Center**, you need to right-click on it and select **Run as Administrator** from the popup menu (this is required by Windows because the application has to run with "elevated access").

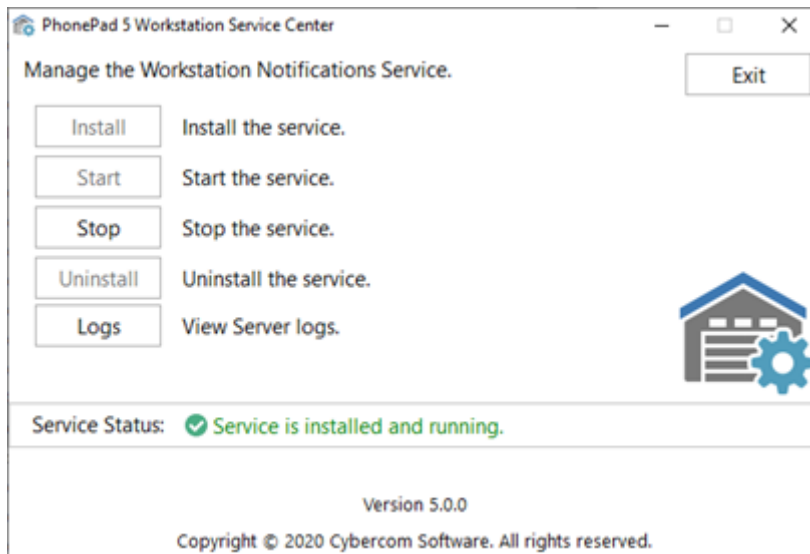

Chapter

22

Example Scenarios

Example Scenarios

This section covers examples on how PhonePad can be set up for different types of offices. More examples will be added in the future.

Setting Up a Common Inbox

If you want an Inbox that is easily accessible by all users, there are a couple of ways you can set this up.

A. Disabled User Account

The first method is to use a disabled user account:

1. Select **User Management** from the **Admin** menu.
2. Add a new user, eg. Sales.
3. Uncheck the **Login Enabled** check box.
4. Select a user from the list of users and click the **Access** button.
5. Give the user access to the new user account you created.
6. Repeat steps 3 to 4 for each user.

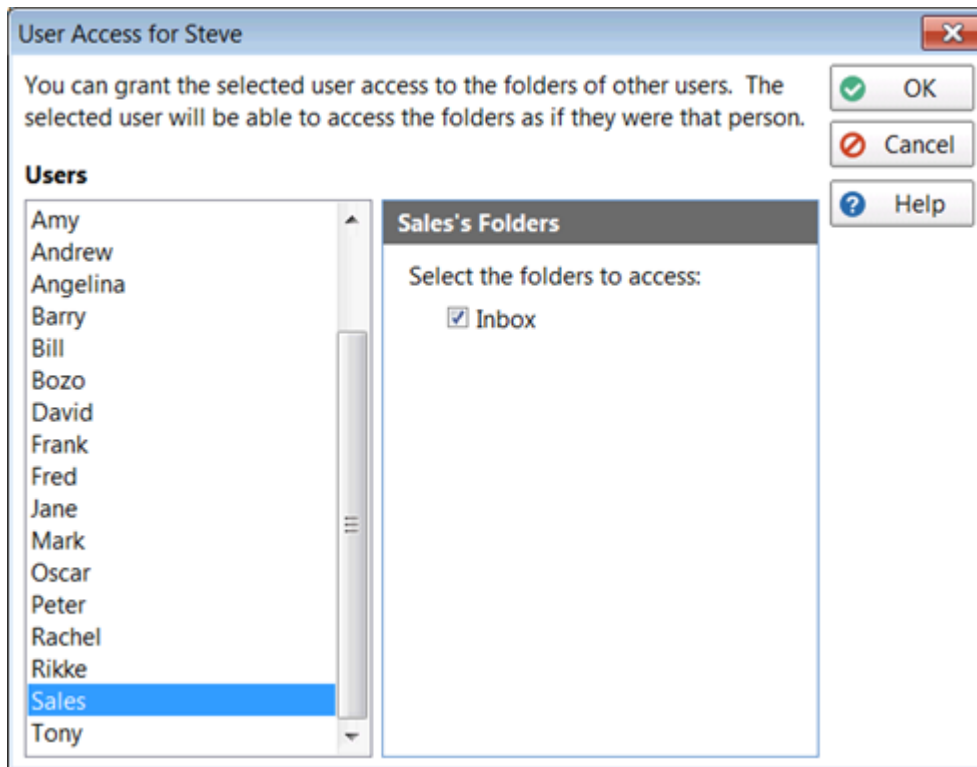

The new user will appear in the user list for each user.

Inbox for Sales		
Abigail	24	14
Amy	1	0
Andrew	58	40
Barry	3	2
Bozo	5	4
Frank	0	0
Rachel	0	0
Sales	1	0
Steve	45	28

When logging phone messages simply send them to the user you created. All users will be able to access the messages from that Inbox via the user list (as shown above).

B. Group Inbox

The second method is to create a Group Inbox:

1. Select **Groups** from the **Admin** menu.
2. Click **Add** to add a new group (or select an existing group and click **Edit**).
3. Select **Use a Group Inbox for receiving messages**.

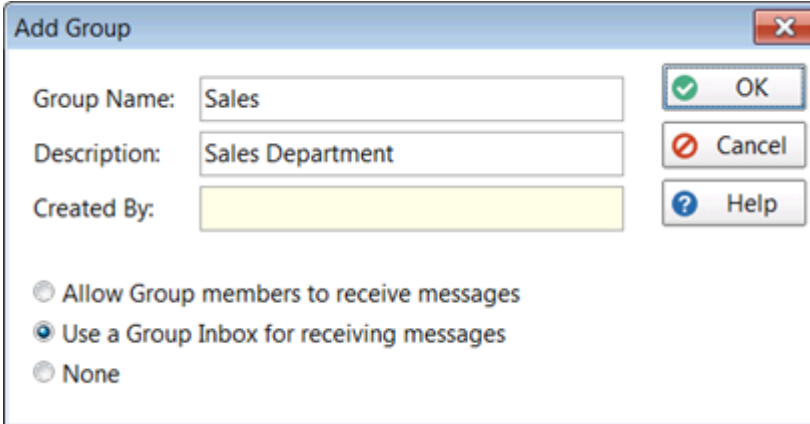

The screenshot shows a dialog box titled "Add Group". It contains the following fields and options:

- Group Name: Sales
- Description: Sales Department
- Created By: (empty field)
- Buttons: OK, Cancel, Help
- Radio buttons:
 - Allow Group members to receive messages
 - Use a Group Inbox for receiving messages
 - None

4. Click **OK**.

The Group Inbox will appear in the user list for each group member, usually at the top. Group Inboxes are always in uppercase and are prefixed with a #.

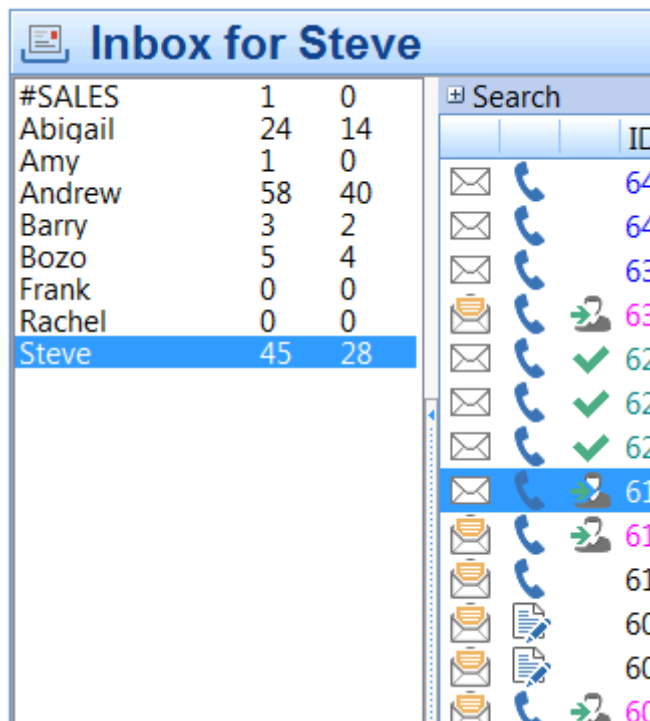

When logging phone messages, address them to the Group you created. Users will then be able to access the Group Inbox via the user list (as shown above).

The added advantage of using groups is that you can set up Group Inboxes for different areas within your organization. For example, auto details may want to set one up for Sales and another one up for Service.

When you click the **OK** button, PhonePad will create a Group Inbox and all group members will automatically be given access to it.

PhonePad for Answering Services

We often get asked if PhonePad can be used by an answering service. This is how many answering services use PhonePad 5 to manage their calls (this will need to be done by a PhonePad 5 administrator).

Step 1: Create a User Account for Each Client

1. Select **User Management** from the **Admin** menu.
2. Add a new user, eg. *John_Smith*.
3. Uncheck the **Login Enabled** check box.
4. Select your username from the list of users and click the **Access** button.
5. Give yourself access to the new user account you created.
6. Repeat steps 3 to 4 for each user.

Step 2: How to Use It

When logging phone messages simply send them to the relevant client you created.

The client's names will appear in your user list. You can access each client's messages by selecting their name from the user list.

When you have passed on a message onto a client, select the message and click the **Mark as Completed** button.



You could use **MessageSender** to automatically forward client's messages to an email address or their cell/mobile phone.

Chapter

23

**Connecting Remotely Over the
Internet**

Connecting Remotely Over the Internet

With **PhonePad Remote** you can connect and login to PhonePad in the office no matter where you are. All you need is a Windows desktop computer or laptop and an Internet connection.

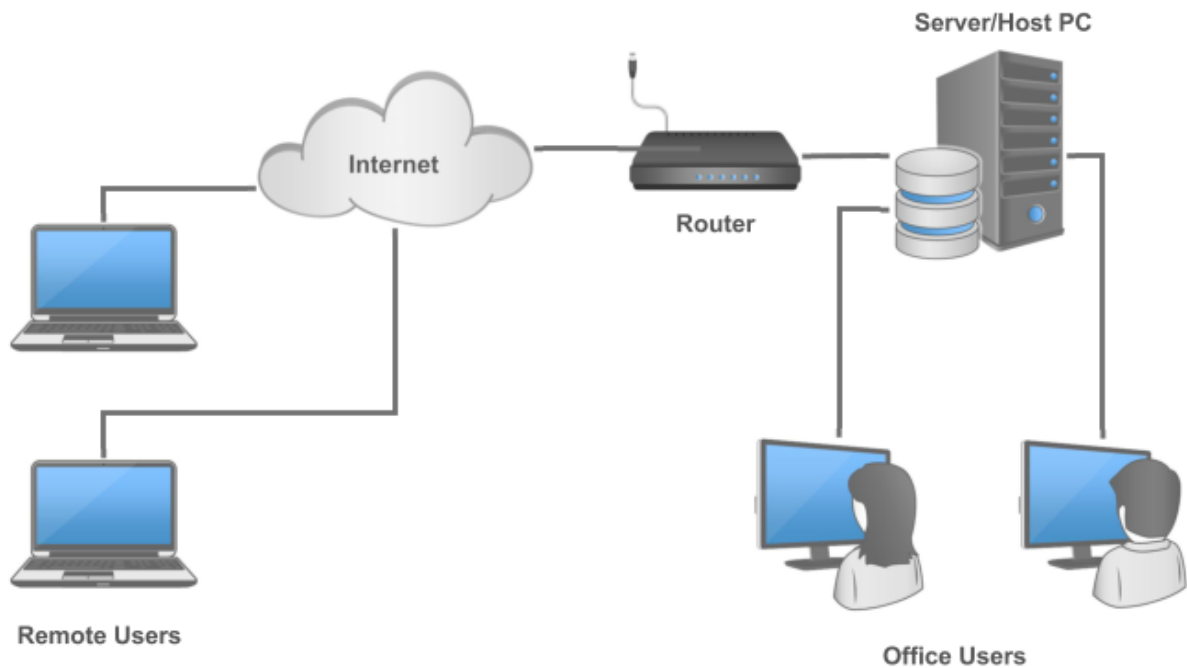

Before you can start connecting remotely there are some things that need to be done:

- Your PhonePad Administrator has to enable remote connections in PhonePad, and configure your router to allow the connections.
- You will need a Remote Access Code from your PhonePad Administrator.
- PhonePad 5 Workstation should be installed on the computer you will be using to connect remotely.

Once that's all be done, run PhonePad Remote on your remote computer.

1. Enter your **Remote Access Code**.



2. Click the **Connect** button



3. PhonePad Remote will attempt to connect to the PhonePad 5 Server in your office. If all goes well you should be presented with the PhonePad 5 login window.

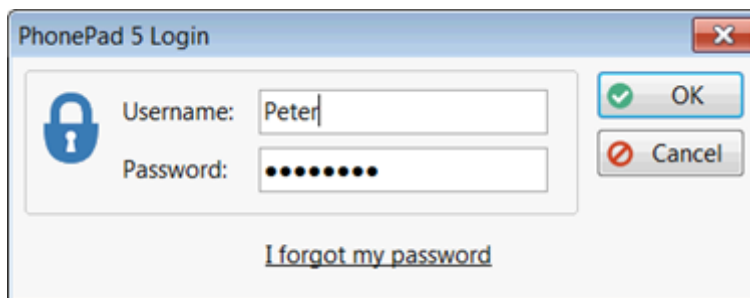

4. Login as you normally would. You will then be able to use PhonePad the same as you would when you are in the office.



PhonePad Remote will only be as fast as your Internet connection. If you have a slow connection then you should avoid using any features in PhonePad 5 that may take a long time to execute.

Chapter

24

Updating PhonePad

Updating PhonePad

PhonePad 5 includes an easy way to update your software to the latest version whenever one is released. Instead of going to the PhonePad website to look for updates, you can check from within PhonePad.

There are basically 3 types of updates in PhonePad 5:

- Server Updates
- Workstation Updates
- Database Updates

Server Updates

A server update includes updates to the server itself, support applications (eg. Database Restore), and documentation (help files, user guides, etc.).

These updates are handled by the application updates.

Workstation Updates

This includes updates to the PhonePad workstation applications (PhonePad5.exe, PhonePad5Run.exe, InstantChat.exe and WhereRU.exe) as well as documentation (help files, user guides, etc.).

These updates are handled by the application updates.

Database Updates

Database updates are changes to your PhonePad 5 database. These include altering your database to fix problems or adding new features.

These updates are handled by the application updates.

 **IMPORTANT WARNING:** Unless you want to start with a new **blank** database, do **not** try updating PhonePad by downloading the latest full server installer from the website. It is designed for fresh, clean installs **not** updates. You

need to download updates using the **Application Updates** feature, or by downloading updates from your account at www.myphonepad.com.

If you use the full server installer to update your Server or Host PC **it will delete your existing PhonePad database.**

How Updating Works

PhonePad 5 has a built-in update system that makes it easy to update your Server or Host PC and each workstation.

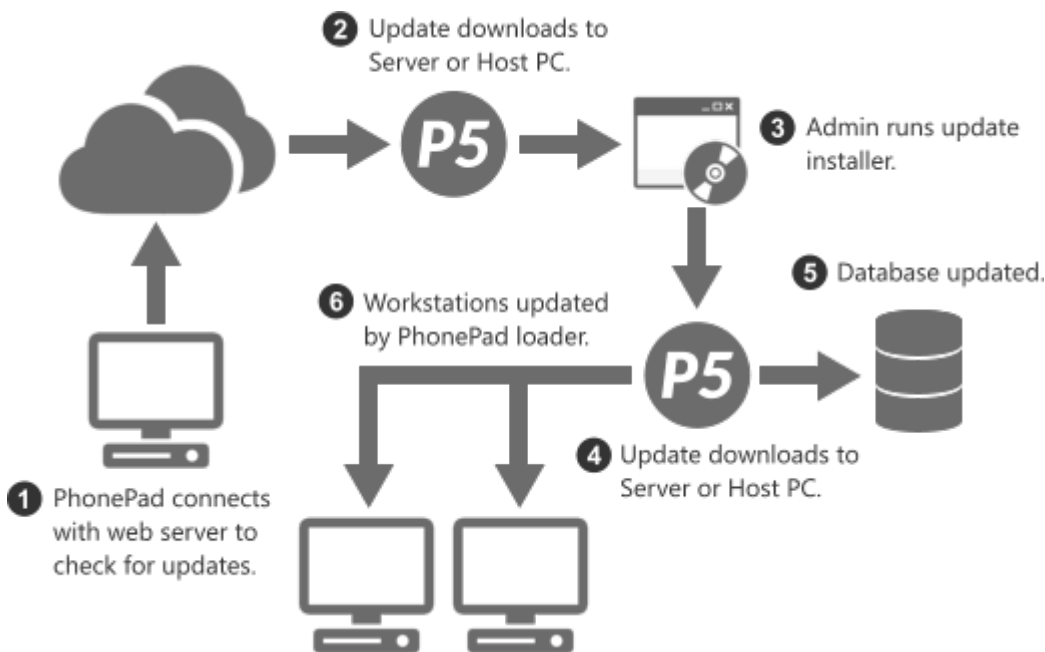

When you install an update on your Server or Host PC, each workstation will be automatically updated the next time the user logs in. No more walking around to each computer and installing an update manually - it's all done for you.

Your PhonePad database will be analyzed and updated to the latest version of the database.

Installing Server Updates

All PhonePad 5 updates are done in the form of server updates. These are always done on the Server or Host PC.

Select **Server Updates** from the **System Admin** menu, or click the **Server Updates** button on the **System Admin** tab.

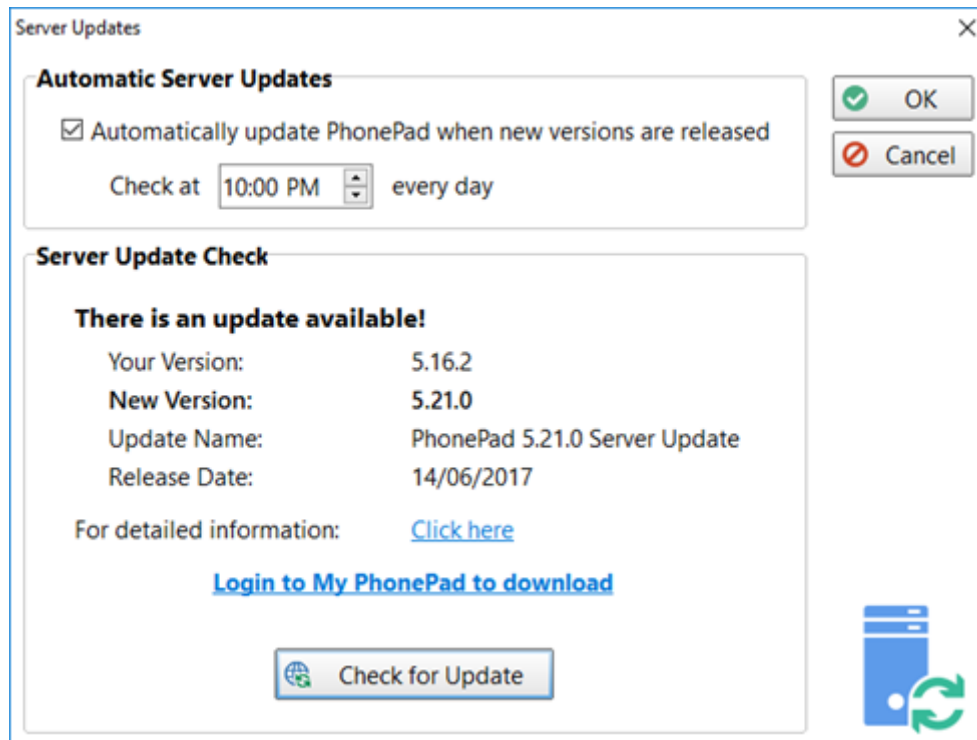

Automatic Server Updates

Check the **Automatically update PhonePad when new versions are released** checkbox to install server updates whenever they are released. They will then be propagated out to the workstations when users start PhonePad.

Set a time each day for PhonePad to check for new versions. Whenever one is found it will be automatically installed.

For Automatic Server Updates to work the **ServerAutoUpdates** service must be installed on the Server or Host PC.

Server Update Check

You can manually check for new versions at any time by clicking the **Check for Update** button. If there is one available, the details will be displayed. If you don't want to use automatic updates then you can login to your MyPhonePad account to download it. Remember, it must be downloaded to and installed on your Server or Host PC.

Updating PhonePad from My PhonePad

Login to your My PhonePad account at www.myphonepad.com.

1. Select **My Downloads**.

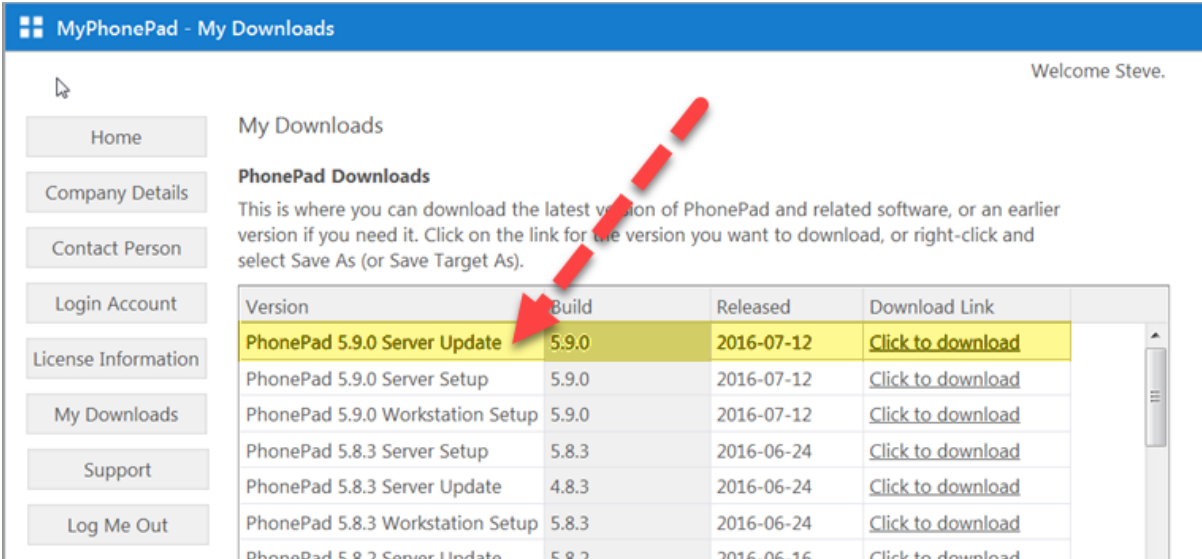

MyPhonePad - My Downloads

Welcome Steve.

Home

Company Details

Contact Person

Login Account

License Information

My Downloads

Support

Log Me Out

My Downloads

PhonePad Downloads

This is where you can download the latest version of PhonePad and related software, or an earlier version if you need it. Click on the link for the version you want to download, or right-click and select Save As (or Save Target As).

Version	Build	Released	Download Link
PhonePad 5.9.0 Server Update	5.9.0	2016-07-12	Click to download
PhonePad 5.9.0 Server Setup	5.9.0	2016-07-12	Click to download
PhonePad 5.9.0 Workstation Setup	5.9.0	2016-07-12	Click to download
PhonePad 5.8.3 Server Setup	5.8.3	2016-06-24	Click to download
PhonePad 5.8.3 Server Update	4.8.3	2016-06-24	Click to download
PhonePad 5.8.3 Workstation Setup	5.8.3	2016-06-24	Click to download
PhonePad 5.8.2 Server Update	5.8.2	2016-06-16	Click to download

2. The latest version will appear at the top of the list.
3. Select the latest *Server Update* and click the **Click to Download** link.
4. Save the download and run it on your Server or Host PC.

With each release there are 3 setup programs:

Server Update *eg. PhonePad 5.9.0 Server Update* This setup program is used to update your PhonePad 5 Server and PhonePad 5 Workstation to the specific version.

Server Setup *eg. PhonePad 5.9.0 Server Setup* This setup program is used for **new installations** of the PhonePad 5 Server on your Server or Host PC.

Caution: If you run it on a Server or Host PC that already has PhonePad 5 Server installed, it will overwrite your existing PhonePad 5 database.

Workstation Setup *eg. PhonePad 5.9.0 Workstation Setup* This setup program is used to install PhonePad 5 Workstation **on a new computer**.

It should not be used to update a workstation, unless you really want a fresh install.

Update Notifications

In addition to being able to check for new versions of PhonePad manually, administrators will get a popup notification in the system tray when a new version is available for download.

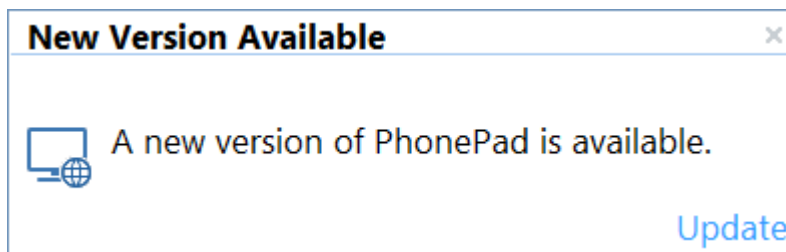

Clicking the **Update** link will take you to the Server Updates screen.

Chapter

25

Troubleshooting Problems

Troubleshooting Problems

These are the most common problems users have experienced.

Startup Problems

This section describes some of the most common start up errors.

Login Validation Error

If this error appears when starting PhonePad, it's usually an indication that your database configuration file has been damaged.

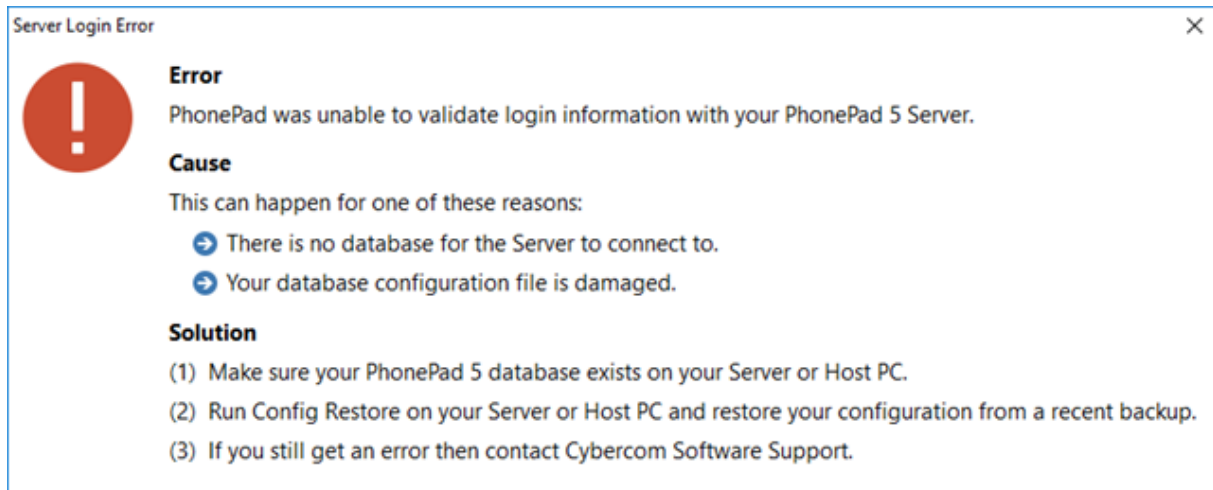

A damaged configuration file can be caused by:

- A Operating System issue.
- A hardware issue or fault.
- The Server or Host PC is powered down without going through the normal Windows shutdown process.
- The Server or Host PC crashes.
- Power surges or lightning strikes.

The PhonePad 5 Server automatically backs up your database configuration file on a daily basis, so if you do get this error you can quickly restore a backed up configuration file (provided that is not damaged as well).

Windows Startup

If you have PhonePad configured to start automatically when Windows starts, in some cases PhonePad may not be able to establish a connection with the Server or Host PC.

Sometimes it can take a few seconds or more for the workstation's network adapter to connect to your network. If this happens then PhonePad will be unable to locate your PhonePad 5 Server will probably display a connection error or may just sit there in a state of limbo.

To resolve this, you can configure PhonePad to wait until a network connection is available:

1. Go to the *PhonePad 5 folder* on your workstation.
2. Run **Workstation Config**.
3. Select the **Settings** tab.

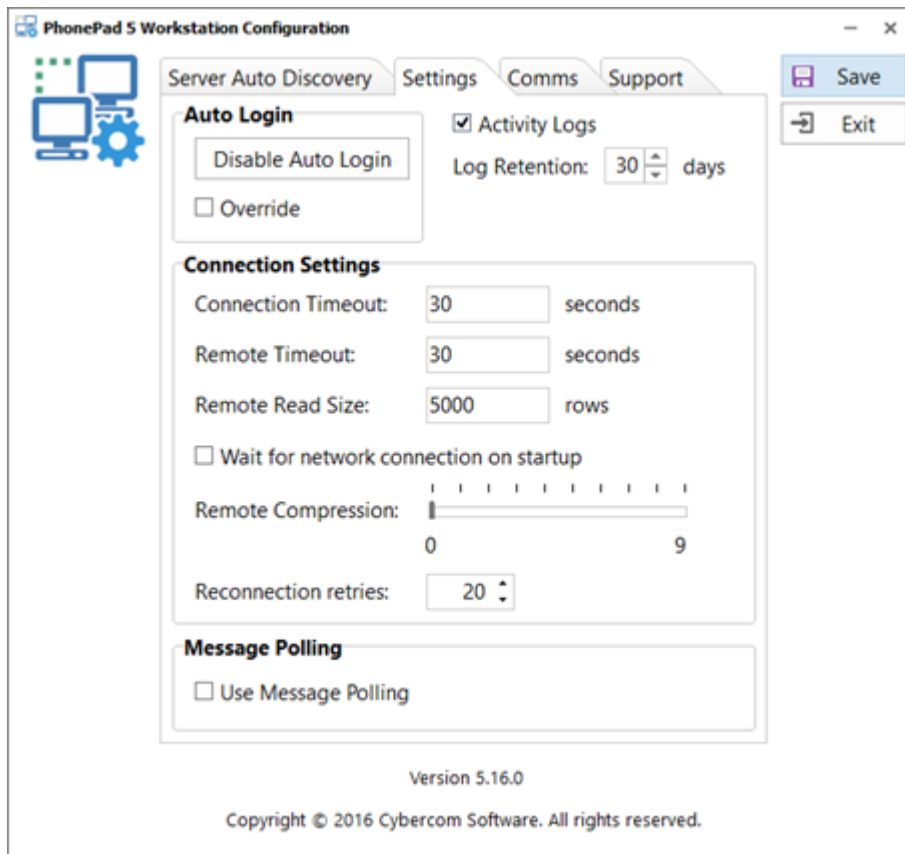

4. Check the *Wait for network connection on startup* check box.
5. Click **Save**.

When you start PhonePad now you will see that it waits for a network connection before proceeding.

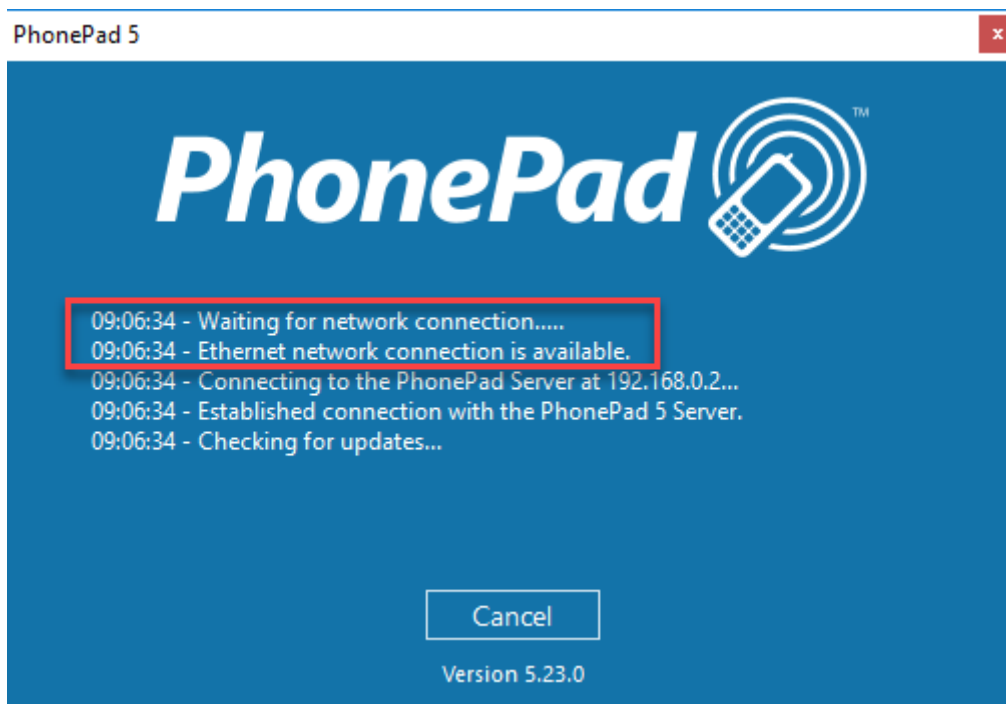

Freezing on Startup

If PhonePad freezes when starting it on your workstation, the most common cause is anti-virus software (or anti-malware, anti-spyware, etc.). This can happen in the following situations:

- You have installed PhonePad for the first time.
- You have updated PhonePad to a new version.
- Your anti-virus software has been updated.

Check your anti-virus software to make sure it is configured to allow PhonePad to run, and that it does not perform any type of real-time scanning of PhonePad. Unfortunately we cannot offer advice or instructions on how to do this as there are dozens of anti-virus products available, and their interfaces change frequently.

You may need to do these checks on both your workstation(s) and Server or Host PC.

Connection Issues

If PhonePad has trouble connecting to the PhonePad 5 Server, there is a program in the PhonePad 5 Server folder on your Server or Host PC called **Process Monitor**. You can use Process Monitor to check to make sure that PhonePad 5 Server has the appropriate ports open, which are: 12600, 12601, 12602, 12603 and 15350.

Run **ProcessMonitor**. You should see the following screen.

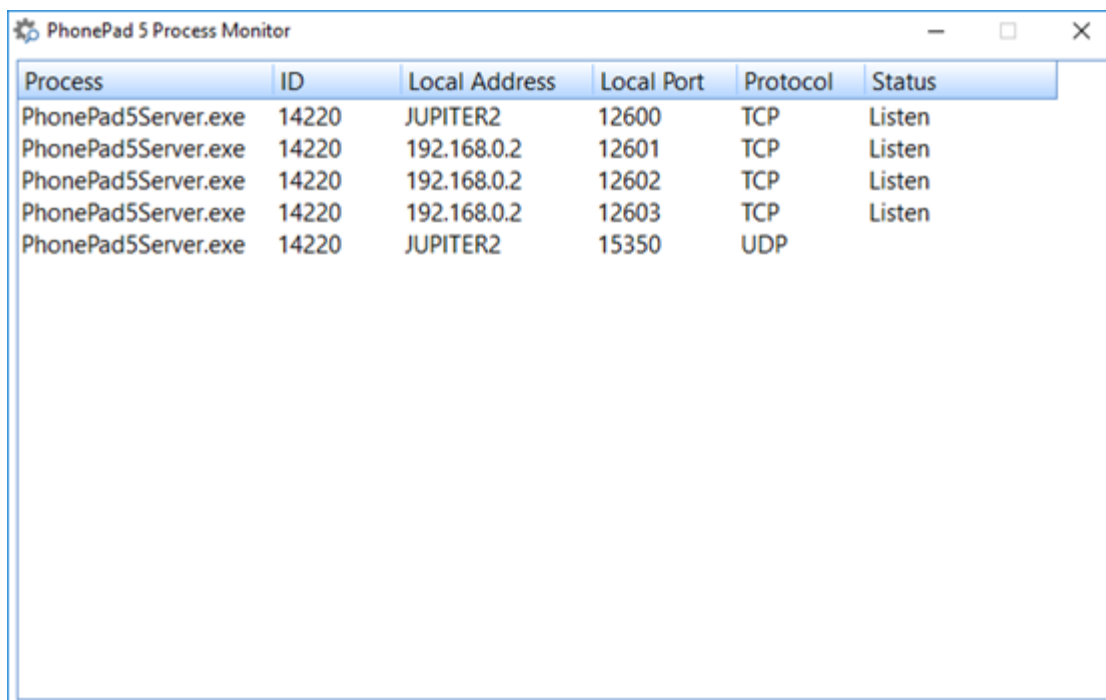

The screenshot shows a window titled "PhonePad 5 Process Monitor" with a table of listening processes. The table has six columns: Process, ID, Local Address, Local Port, Protocol, and Status. There are five rows of data, all for the process "PhonePad5Server.exe" with ID "14220".

Process	ID	Local Address	Local Port	Protocol	Status
PhonePad5Server.exe	14220	JUPITER2	12600	TCP	Listen
PhonePad5Server.exe	14220	192.168.0.2	12601	TCP	Listen
PhonePad5Server.exe	14220	192.168.0.2	12602	TCP	Listen
PhonePad5Server.exe	14220	192.168.0.2	12603	TCP	Listen
PhonePad5Server.exe	14220	JUPITER2	15350	UDP	

When PhonePad 5 Server is running you should see similar results. Of course, the process ID and Local Address will be different, but the Local Ports and Protocols should be the same.

If port 12600 is not displayed then there is a problem with the port.

1. **Try stopping and starting the PhonePad 5 Server** using Control Center to see if that resolves it.
2. Check to make sure there are no firewalls blocking the connection.
3. Check your anti-virus/anti-malware/anti-spyware software to see if that is blocking the connection.



Process Monitor can also be started from the Control Center. Just select **PhonePad Server** and then click the **Processes** button.

I/O Error 103

If you get this error when starting or using PhonePad 5, it is a Windows permissions problem, ie. you don't have sufficient access rights to specific folders on your workstation.

PhonePad often needs to be able to write to these folders so that it can automatically install updates and record log events.

Fortunately this is easily fixed, although you will need to login as a Windows administrator on the workstations getting this error.

What you need to do is set the user permissions to at least **Modify** for the following folders:

- **C:\PhonePad5**
- **C:\ProgramData\Cybercom Software\PhonePad5**

On many computers the **C:\ProgramData** folder is hidden by default by Windows. In that case you may need to type the path in on Windows Explorer's address bar.

These are the permissions that need to be set for both folders:

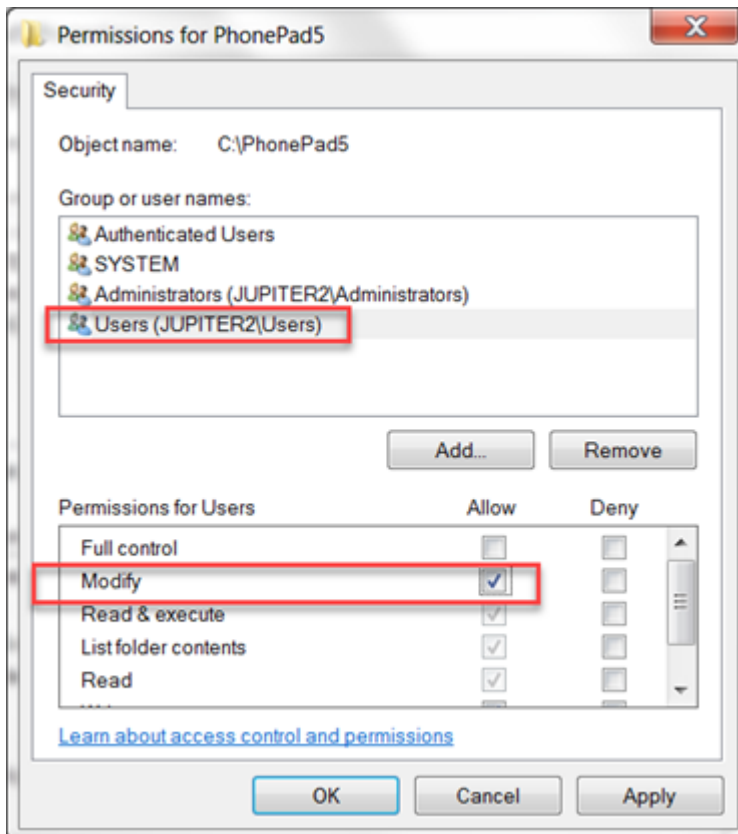
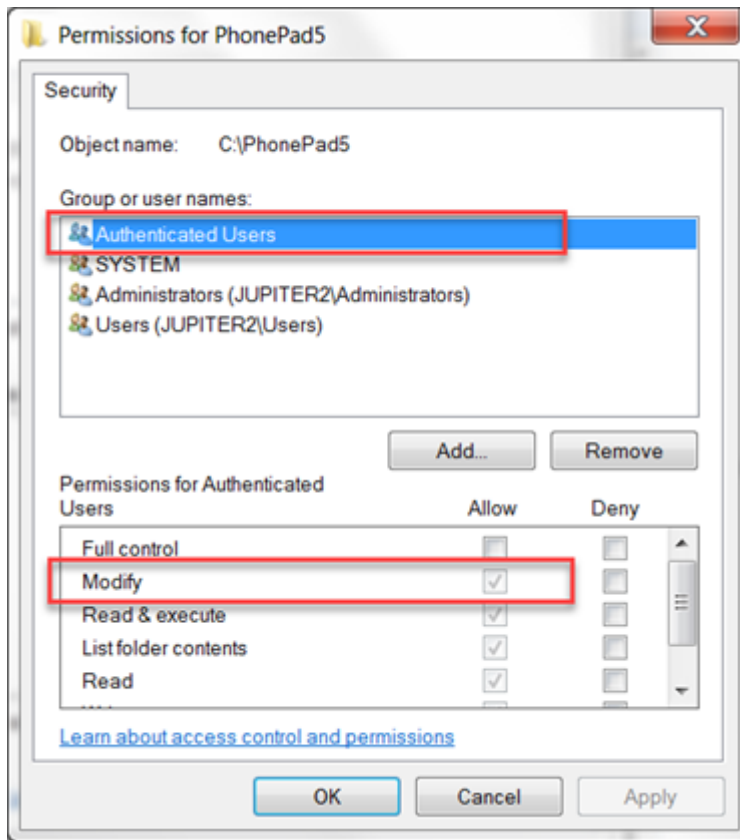

Checking Windows Permissions

You can easily check to see if your PhonePad folders and files have the correct permissions by downloading and running the **PermissionsCheck** application on your Server or Host PC, and your workstations.

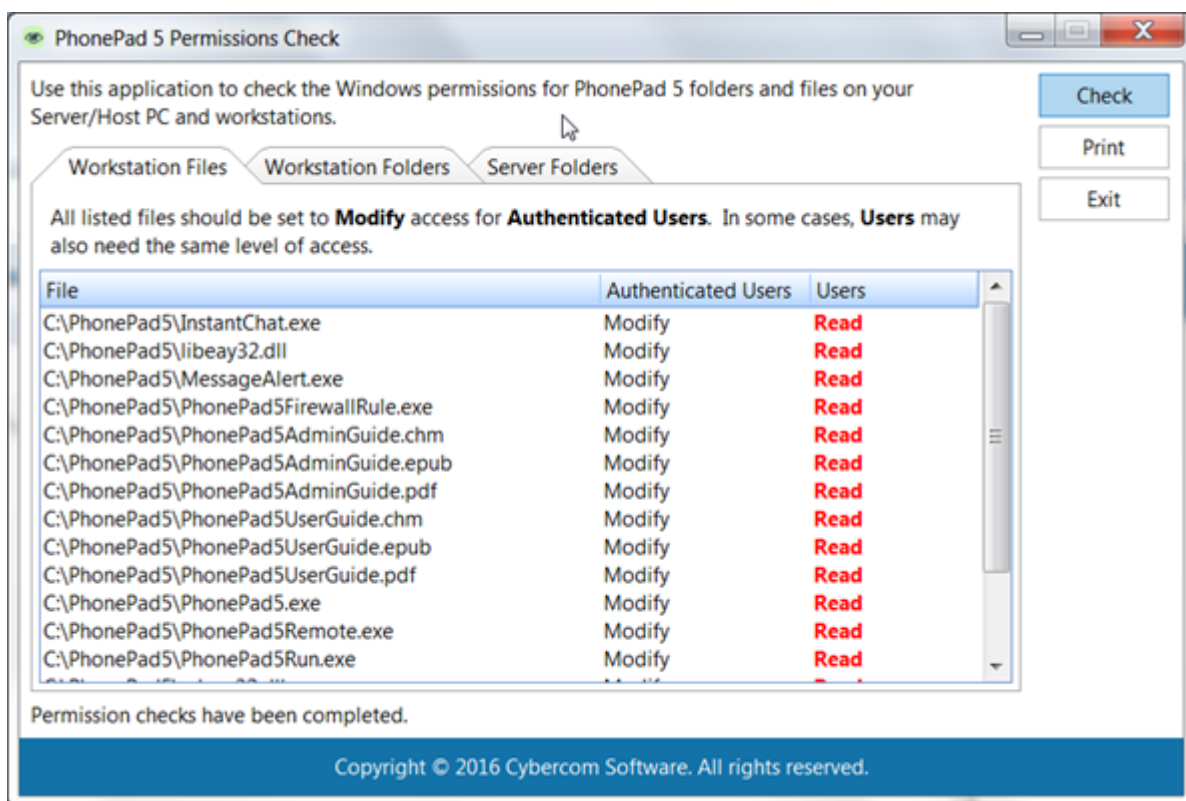

Any potential access rights problems will be show in red.

You can download it here.

Speed Issues

If you're experiencing performance problems with PhonePad 5 then there are a number of things that can cause this

Anti-Virus and Anti-Spyware Software

Anti-virus and anti-spyware can severely impact the performance of PhonePad 5. Read more about this in the section entitled **Anti-Virus, Anti-Spyware and Other Security Software** in the **Other Information** section of the **Admin Guide**.

Network Connectivity

If your network experiences connectivity issues like dropouts, loss of data packets, etc. this can significantly impact performance.

Loss of data packets will cause the data has to be resent, and this will be repeated until the complete packets are received at the other end.

Connectivity drop outs will trigger PhonePad to attempt to re-establish the connection. This takes time. Frequent dropouts will definitely slow things down.

You can check if there have been connection problems:

1. Select **System Logs** from the **System Admin** menu,
2. Click the **System Events** tab.
3. The following example screenshot shows that there were some network problems that caused loss of connection between the workstation and server.

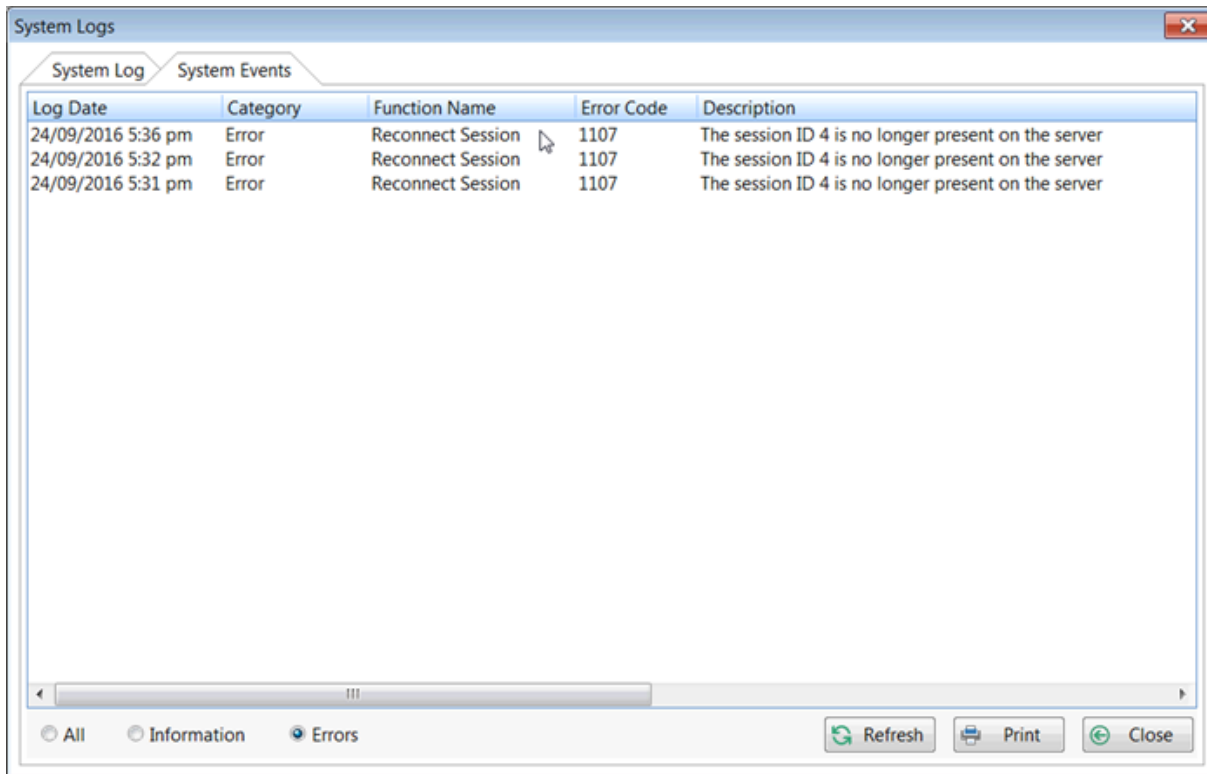

High Network Traffic

If your network is congested with activity this can also affect the speed of PhonePad. While you may be able to open documents over your network without much delay, keep in mind that PhonePad is a networked based data application that can access a lot of data within a short amount of time, so in some way it can be more sensitive to high levels of network traffic.

Heavy Server Load

An overworked Server can definitely affect the performance of any database-based system. A high number of users, high memory usage, and excessive disk activity can all reduce performance.

If you have a Host PC instead of a dedicated server, high amounts of processing on the Host PC can also affect the response time.

This page intentionally left blank.

Chapter

26

Connection Issues

Connection Issues

If PhonePad has trouble connecting to the PhonePad 5 Server, there is a program in the PhonePad 5 Server folder on your Server or Host PC called **Process Monitor**. You can use Process Monitor to check to make sure that PhonePad 5 Server has the appropriate ports open, which are: 12600, 12602, 12603 and 15350.

Run **ProcessMonitor**. You should see the following screen.

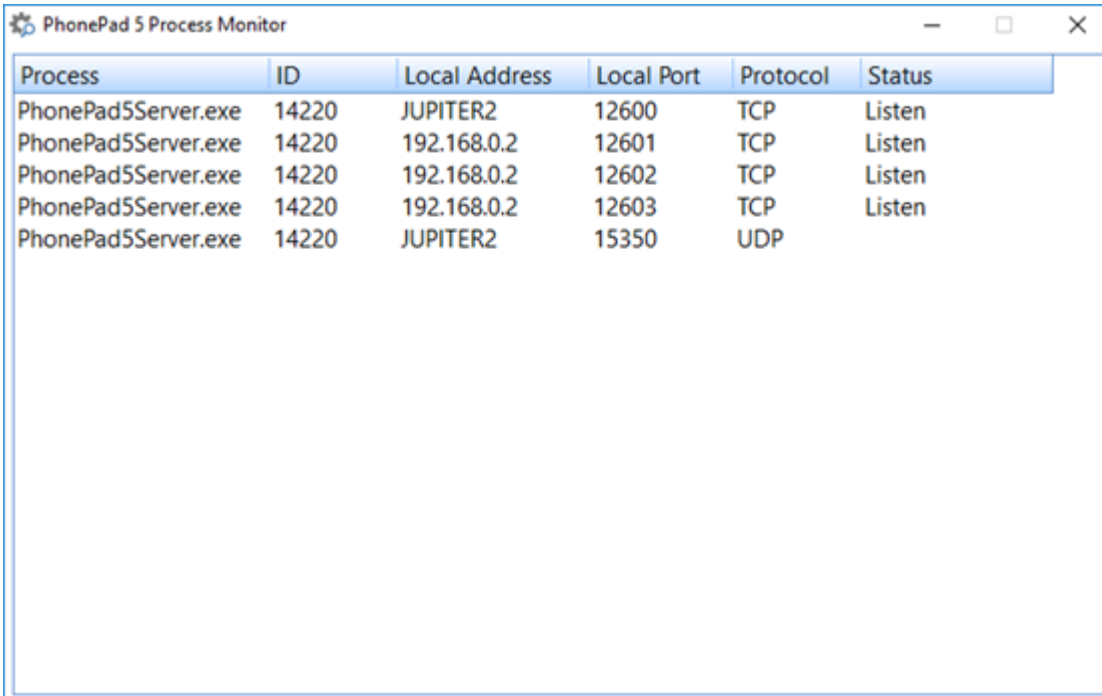

The screenshot shows a window titled "PhonePad 5 Process Monitor" with a table containing the following data:

Process	ID	Local Address	Local Port	Protocol	Status
PhonePad5Server.exe	14220	JUPITER2	12600	TCP	Listen
PhonePad5Server.exe	14220	192.168.0.2	12601	TCP	Listen
PhonePad5Server.exe	14220	192.168.0.2	12602	TCP	Listen
PhonePad5Server.exe	14220	192.168.0.2	12603	TCP	Listen
PhonePad5Server.exe	14220	JUPITER2	15350	UDP	

When PhonePad 5 Server is running you should see similar results. Of course, the process ID and Local Address will be different, but the Local Ports and Protocols should be the same.

If port 12600 is not displayed then there is a problem with the port.

1. **Try stopping and starting the PhonePad 5 Server** using Control Center to see if that resolves it.
2. Check to make sure there are no firewalls blocking the connection.
3. Check your anti-virus/anti-malware/anti-spyware software to see if that is blocking the connection.



Process Monitor can also be started from the Control Center. Just select **PhonePad Server** and then click the **Processes** button.

This page intentionally left blank.

Chapter

27

Support

Support

We have been supporting our products for over 20 years.

If you have any problems with downloading, installing, configuring or using PhonePad 5 please contact us instead of your normal IT support provider. As good as your IT people are, we know PhonePad better and can probably pinpoint the problem and fix it a lot faster.

Please visit the **Support** page for information on support options:
<https://www.cybercom-software.com/support>



Chapter

28

Update Plan

Update Plan

Developing software is a time consuming and expensive business. So that we can continue to develop PhonePad and provide more frequent releases, we have annual Update plans. An Update Plan provides you with all major and minor updates that are release during the period of the Update Plan. A 12 month update plan is provided with your purchase of PhonePad 5. After 12 months you have the option of renewing your update plan. PhonePad will continue to work regardless of whether or not you renew your update plan.

To check your Update Plan, select **Update Plan** from the **Help** menu.

In the first example it shows a current Update Plan that doesn't expire until the date shown.

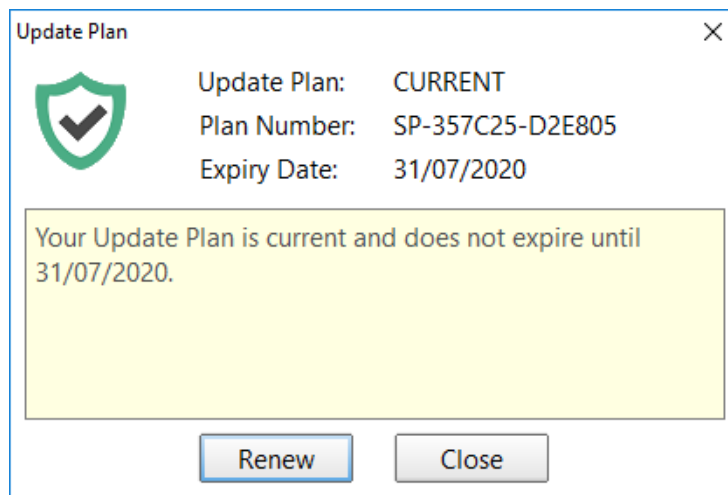

In the next example the Update Plan has expired.

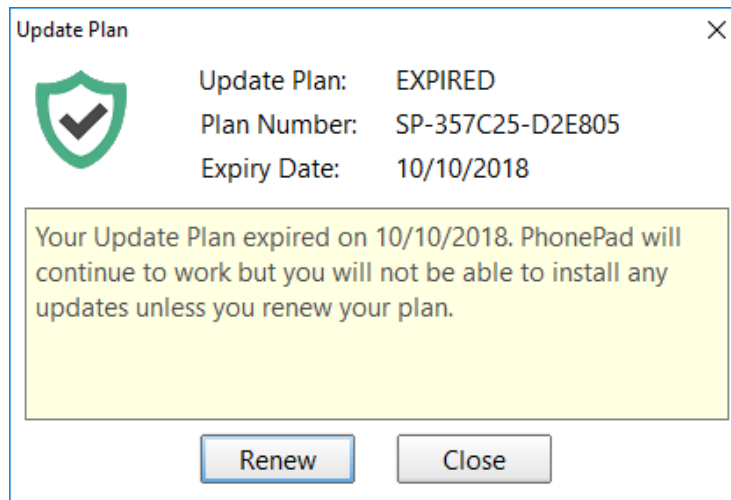

The Update Plan can be renewed at any time, either while your plan is current or when it has expired. If you renew your Update Plan while it is still current you will get a full 12 months added on to the end of your plan's expiry date, so you don't lose anything by renewing early.

If you are in the Trial period you will be on the Trial Update Plan. You are still eligible to updates during this period.

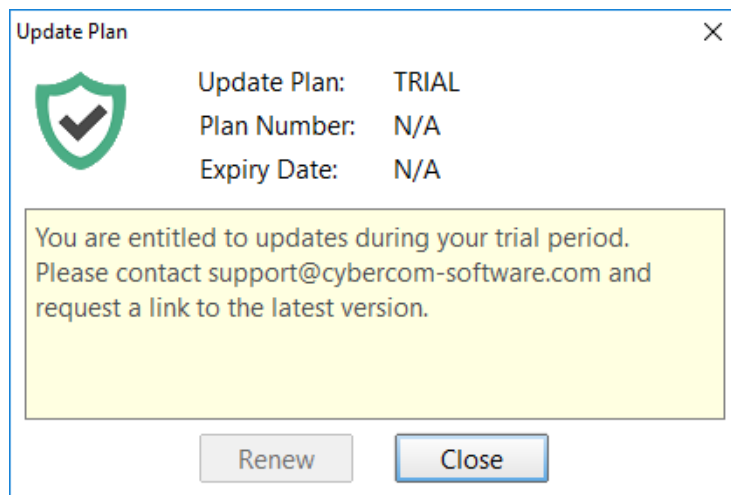

Renewing Your Update Plan

1. When you're ready to renew your Update Plan, click the **Renew** button.

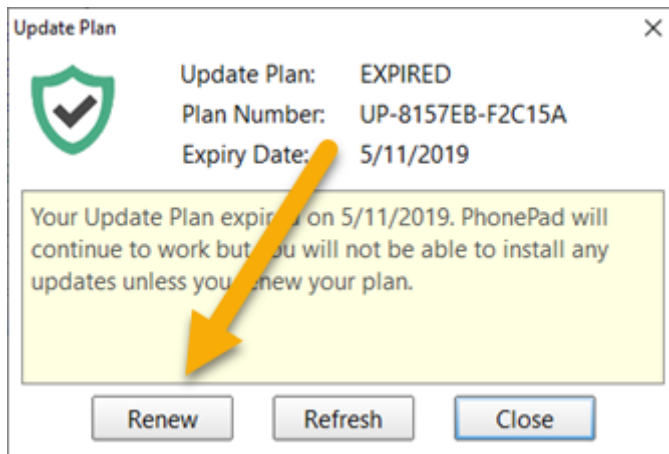

2. The **Update Plan Renewal** window will be displayed.

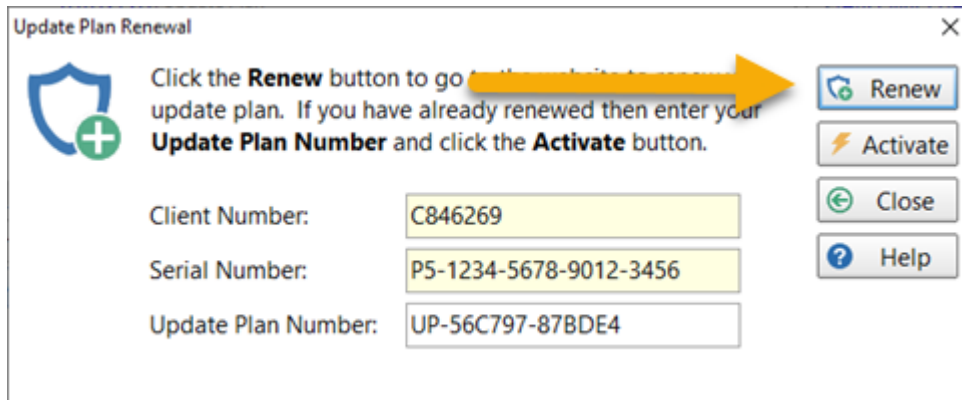

3. Click the **Renew** button on this screen. You will be taken to the Update Plan Renewal website.



Update Plan Renewal

Renew your Update Plan today for another 12 months and continue to receive major updates and minor updates.

Client Number: C846269
Company: Fluffy Rabbit Corporation
Serial Number: P5-1234-5678-9012-3456
No of Users: 5
Price: \$29.00

[Renew Now](#)

Your IP Address is 124.180.203.185

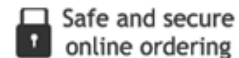

NOTE: Prices shown are in US dollars.

4. Your details will be automatically filled in and the renewal amount for 12 months will be calculated.
5. Click the **Renew Now** button to pay for the renewal and follow the prompts.
6. Once your payment has been processed you will receive an email containing your **Update Plan Number**.
7. Enter the **Update Plan Number** and click the **Activate** button. PhonePad will be updated with the new Update Plan.

Refreshing Your Update Plan

If you have renewed your Update Plan and haven't received an email from us, or you believe your Update Plan details aren't correct, you can click the **Refresh** button to

retrieve your Update Plan details from our system and update your PhonePad database.

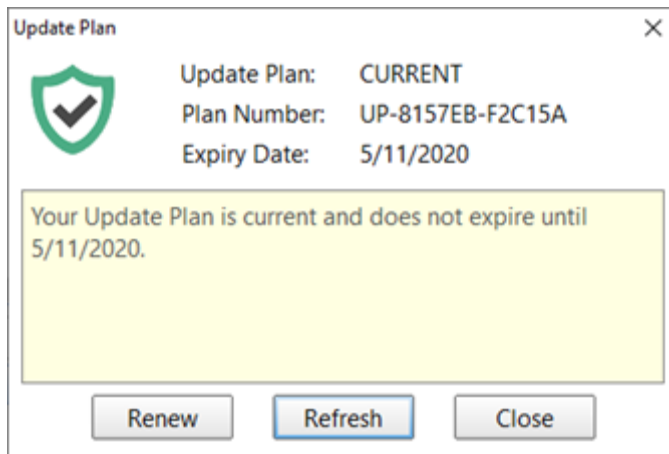
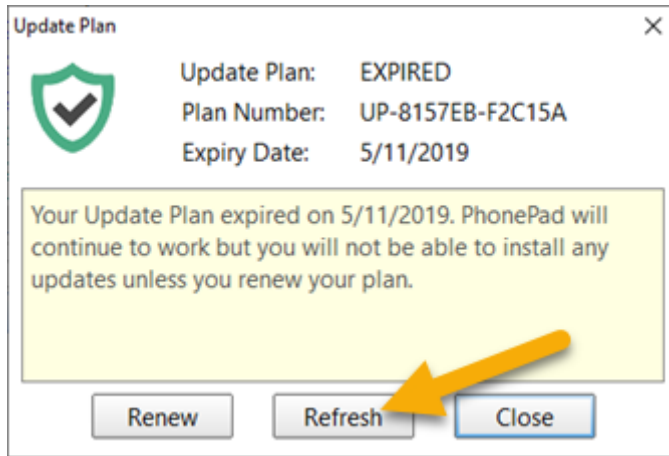

Index

- " -

"to-do" list 312

- < -

<alt> 117, 174

- A -

A to Z 261
 About 31
 Access 336
 access rights 359
 Access the PhonePad Address Book 28
 Accessing a Group Folder 170
 Accessing a Personal Folder 160
 Accessing a Public Folder 165
 Activate 371
 Activity Logs 216
 Add a Follow Up Note 184
 Add Follow Up note 30
 Add New Caller 73
 Add Reminder 30
 Adding a Document 280
 Adding a Group Folder 168
 Adding a Personal Folder 158
 Adding a Public Folder 163
 Adding a Sub-Folder 172
 Address Book 35, 45, 76, 236, 260, 261, 277
 Address Book settings 277
 Address Tabs 261
 Address Type 73
 Admin Guide 31, 38
 administrator access 133
 Advanced 37, 57, 58
 alert window 222
 All tab 261
 announcement 243
 answering service 339
 answering services 339
 anti-spyware 286

Anti-virus 286
 Anti-Virus and Anti-Spyware Software 360
 anti-virus software 355
 Application information 286
 Application minimizes when X button clicked 219
 Application Updates 350
 Appointment Calendar 244
 Appointment Notifications 244
 Appointment Reminders 244
 Archive Messages 35
 Attachment 115
 Auto Forward 317, 323
 Auto Suggest 137
 auto-discover 16, 20
 Automatic Message Forwarding 31, 35, 112, 248, 315, 317, 323
 automatically forward client's m 339
 Automatically Marking Messages for Follow Up 184
 Automatically refresh Follow Up Notes 233
 Automatically set follow ups 182
 Availability 256

- B -

Basic 37, 57
 built-in update system 347
 Button Size 289

- C -

Call 206
 Call History 200, 202
 Caller ID 31, 196, 203, 204, 238
 Caller ID hardware 201
 Caller ID Service 198
 Caller ID Settings 31, 204
 Caller Information 37, 40, 53, 199, 205, 225
 Caller Notes 64
 CallerID.com 200
 CallerID.com. 196
 CallFlow 37, 260
 calls received 206
 CAPS LOCK 24
 Category 45
 Change PhonePad 31

Change read message color when follow up has been completed 233

change the order of columns 47

change the width of columns 47

Change to Personal Folder 166

Change to Public Folder 161

Changing a Personal Folder to a Public Folder 161

Changing a Public Folder to a Personal Folder 166

Changing Your PhonePad Password 214

Check for new messages 28

Check Inbox 33

Checking Windows Permissions 359

Clear 276

Clear Return Time 319

close the chat window 300

Closing Instant Chat 302

Color Coding 50

Columns 45, 277

columns displayed in the message lists 48

Comments 320

Company 73

complete history 121

Configuring a TAPI Device 204

Configuring the Toolbars 58

Confirm Message Deleted 225

Confirm Message Deletions 225

congested 361

connecting 356, 364

connection 342

Connection Issues 356

Connection Troubleshooter 16

connectivity 360

connectivity issues 360

contact names 261

Contact Type 45, 262

Control Bar 35, 216, 288, 289

Control Center 198, 334, 356, 364

correct permissions 359

Create a new folder 29

Create a User Account for Each Client 339

Create new incoming phone message 28

Create new outgoing phone message 28

Create Reminder for Follow Up 233

Create text message 28

Creating a Text Message 99

Custom 37, 57, 58

Customize Toolbar 37

- D -

damaged configuration file 352

data packets 360

database configuration file 352

Database information 286

Database Statistics 286

Database Updates 346

Date of Birth 262

Date/Time Stamp 85

Default Message Action 225

Default Phone Message Settings 225

Delete 273, 282

Delete a folder 29

Delete a Follow Up Note 186

Delete Follow Up note 30

Delete Message 28, 33

Deleted 41, 173, 176

Deleted Folder 120, 156

Deleting a Document 282

Deleting a Group Folder 169

Deleting a Personal Folder 159

Deleting a Public Folder 164

Deleting All Entries 276

Deleting Messages 120

Description 280, 281

Dial 206

Dial Number 33, 206

Dial phone number 28

Display alert window in system tray 222

Display Caller Information 204

Display Follow Up Notes window on completion 233

Display popup balloon in system tray 222

Display popup messages 222

Document Name 280, 281

Document Type 280, 281

Documents 279

Documents Tab 262

Double Left Click 219

double-clicks 219

drag 174

drag and drop 117, 174

Drag and Drop Your Messages 174

dragging and dropping 176

dropouts 360

- E -

Edit 273
 Edit a folder 29
 Edit a Follow Up Note 185
 Edit an Address Book Entry 273
 Edit Follow Up note 30
 Editing a Group Folder 169
 Editing a Personal Folder 159
 Editing a Public Folder 163
 Editing Received or Sent Messages 119
 Email 248, 250
 Email Message 33, 132
 email message header 113
 Email Message Settings 133
 Email messages to these addresses 132
 Email selected message 28
 Empty a folder 29
 Emptying a Group Folder 170
 Emptying a Personal Folder 160
 Emptying a Public Folder 165
 Enter an email address 132
 establish a connection 353
 Ethernet 196
 Example Printouts 126
 excessive disk activity 361
 Exit 302
 Exit (and Logout) 33
 Exit PhonePad 28
 Export 276
 Exporting Your Contacts 276
 external copy of a document 282
 external user 70
 External Users 70

- F -

Family Tab 262
 Female 243
 File 132
 File Menu 33
 Filename 280
 Filter Messages 230
 firewall software 286
 Firstname 73

flashing 59
 Folder Message Counts 176
 Folder Navigation Bar 179
 Folder Tree 41
 Folders 150, 174
 Follow Up 33, 182, 183, 184, 185, 186, 187, 200, 233, 312
 Follow Up By Date 233
 Follow Up Notes 40, 52, 53, 184
 Follow Up Notes tab 53
 Follow Ups 225
 Following Up 182
 Forward message 28
 Forward to Other PhonePad Users 248
 Forward Via Email 250
 Forward Via Pushover 254
 Forward Via SMS 252
 Forwarding Messages 116

- G -

General settings 216
 Getting Started 16
 Global Search 210
 Global Searching 210
 Google Maps 73
 group 43
 group folder 174, 176
 group folders 167, 176
 Group Inbox 43, 338
 Group Inboxes 43
 Groups 176, 338
 Groups Folders 41
 Guided User Interface Help 55

- H -

Heavy Server Load 361
 Help 31, 286
 Help Menu 38
 high amounts of processing 361
 high memory usage 361
 High Network Traffic 361
 high number of users 361
 History 118
 History Graph 202
 History List 201

Home tab 260
 Horizontal 289
 How Updating Works 347

- I -

I Forgot My Password 24
 Identification 45, 262
 Import 273
 Important Information About Automatically Forwarded Emails 257
 Importing Your Contacts 273
 Inbox 40, 41, 150, 176, 210
 Inbox Filtering 33
 Incoming Calls 201, 202
 Insert Separator at Bottom 85
 Insert Separator at Top 85
 Installing the Caller ID Service 198
 Instant Chat 35, 298
 insufficient access rights 22
 Introduction 14

- J -

Jump On 289

- K -

Keywords 280, 281

- L -

Lastname 73
 Latest News 31, 38
 left mouse button 117, 174
 License 31, 38
 License Details 286
 Local Address 356, 364
 Local Ports 356, 364
 Logging In 24
 Login Enabled 336
 Login Validation Error 352

- M -

Maintain Status Text 317, 321

Male 243
 Manage Reminders 30
 Map 73
 Mark as Completed 339
 Mark Follow Up as Completed 30
 Mark Follow Ups as Completed 183
 Mark for Follow Up 183, 184
 Mark Messages for Follow Up 182
 Mark messages to be followed up 182
 Mark messages when follow up has been completed 182
 Mark/unmark message for Follow Up 30
 Menus 32
 Message Alert 35, 306
 Message Colors 225
 Message Confirmation Dialogs 225
 Message Counts 150, 176
 Message Filter 40, 152
 Message Filtering 152
 Message History 118
 Message List Columns 48
 message lists 45, 47
 Message Notification 222
 Message Notification Service 59
 Message Preview 37, 53, 225
 Messages 64
 Messages - 1 225
 Messages - 2 227
 Messages - 4 230
 Messages-4 176
 MessageSender 248, 254, 339
 MID (Message Identifier). 257
 MIDs 257
 minimize 219
 Move Completed messages to this folder 233
 Move messages to another folder 29
 Move Messages to Folder 174
 Move to Folder 174
 Moving Folders 176
 Moving Messages 174
 Moving Messages to Another User's Inbox 117
 multi-tab toolbar 28
 My Downloads 349
 My PhonePad 349

- N -

Navigation Bar 179
network adapter 353
network connection 353
new Address Book entry 262
New Outgoing Message 33
New Phone Message 33
New Text Message 33
Notes 64
Notes Tab 262
notification 350
Notification Sound 222

- O -

online PhonePad account 31
online support center 31
Opacity 289
Open Instant Chat 28
Open WhereRU 28
Opening a Document 282
Options 64, 85
order of columns 47
Orientation 289
Outgoing 41, 176
Outgoing Calls 201, 202
Outgoing Folder 154
Outgoing Messages 232
overworked Server 361

- P -

Password 35, 214
performance 359
PermissionsCheck 359
Personal 179
Personal Folder 174
Personal Folders 41, 158, 176
Phone Messages 86
Phone Messages (Incoming) 64
Phone Messages (Outgoing) 86
phone number 73
PhonePad 5 Server software 22
PhonePad 5 Workstation software 22

PhonePad freezes when starting 355
PhonePad Home Page 31
PhonePad license details 31
PhonePad Remote 342
PhonePad Web Password 35
PhonePad Workstation Service Center 59
Popup Hint Style 216
popup notification 300
ports open 356, 364
Position 289
preferences 37, 152, 176, 204, 216
Preview 40, 122
Print 33, 122, 273
Print message 28
Print Message List 28, 33, 131
Print Messages 122
Print Setup 33
Printing Follow Up Notes 187
Printing Messages 122
Printing Options 124
Private Entry 262
Processes 356, 364
ProcessMonitor 356, 364
Protocols 356, 364
Public 179
Public Folder 174
Public Folders 41, 162, 176
Purchase 38
Pushover 248, 254

- Q -

Quick Print 33, 131
Quick print message 28

- R -

Read Receipt 112
real-time scanning 355
reassign 117
Received Calls 37, 206
red icon 59
Reference 45
Refresh 316, 373
Refresh User List 35
Refreshing Your Update Plan 373

Reminder 233
 Reminder for Follow Up 233
 Reminders 234
 Remote Access Code 342
 Renew Now 371
 renewal 371
 Renewing Your Update Plan 371
 Reply to message 28
 Replying to Messages 116
 Resend message 28
 Resending Messages 117
 Reset Status 320
 Reset Status for All Users 320
 Reset Status for Selected User 320
 Reset your status 315
 Return Time 318
 Return to Inbox 210
 Returning 316, 318
 Run as Administrator 334
 Run from system tray 219
 Run minimized on startup 219
 Run on Windows startup 219

- S -

Saving a Document 282
 search 35, 40, 51, 178, 210, 277
 Search Bar 51
 Search for a message 28
 Search Text 51
 Searching for Documents 283
 Searching for Folders 178
 Sending Options 33
 Sent 41, 176
 Sent Folder 155
 Server Setup 349
 Server Update 349
 server updates 346, 348
 Set Follow Up By Date to x days after message date 233
 Set reminders 182
 Setting Up the Connection to the Server 16
 Setting Your Status 317
 Settings 133, 301
 Short Messaging Service 252
 shortcuts 296
 Show Due Reminders Popup 234

Show follow ups on startup 233
 Show Follows Ups 37
 Show Message Counts 150, 176, 225
 Show new message forms on top 230
 Show Platform 289
 Show User Details 317
 Show Zeroes 150
 Smart Assistance 137, 216
 Smart Suggest 137
 Smart Suggestions 216
 SMS 248, 252
 SMTP Port 133
 SMTP Server 133
 Sort Userlist 317
 Speed Issues 359
 splash screen 25
 Splitters 54
 Standard 37, 57
 Start Chat 298
 starting PhonePad 20, 352
 Startup 219
 Startup Errors 352
 Startup Options 219
 status 315, 317
 status bar 44, 59
 status text 319, 321
 sub-folder 172
 sub-folders 179
 Subject 257
 Suggest 216
 suggestions 31
 Support 38
 Support Plan 38
 Switch to Inbox 222
 Switch User 33
 System Events 360
 System information 38, 286
 System Logs 360
 system tray 219, 306
 System Tray Notifications 222

- T -

Take a Message 199, 205
 TAPI 196, 204, 206
 TAPI Device 204
 TAPI devices 203

TAPI-compliant device 204
 taskbar 288
 Taskbar Notifications 222
 Telephone Setup 204, 238
 Text Messages 97
 Time You Will Be Back 318
 Tip of the Day 26, 31, 38
 ToDo List 312
 toolbar 58
 Toolbar Configuration 57
 Tools 312
 Tools menu 35, 323
 total number of messages 176
 track emails 257
 transparency 289
 Trial Period 23
 Trial Update Plan 370

- U -

unable to locate your PhonePad 5 Server 353
 Uncompleted Follow Ups 225
 Undelete a message in the Deleted folder 29
 Undelete Messages 120
 Undeleted Folder 173
 Unmarking a Message for Follow Up 184
 Unread Messages 225
 update 347
 Update Entry 76
 Update Plan 31, 370, 371, 373
 Update Plan Number 371
 update system 347
 update your Server or Host PC 347
 Updating PhonePad 5 346
 Updating PhonePad from My PhonePad 349
 Updating PhonePad Using Application Updates 348
 upgrade 31
 Use a Group Inbox for receiving messages 338
 User Details 317, 321
 User Guide 31, 38
 User Information 286
 User Interface 27
 User Interface Mode 37, 57, 58
 User Interface Modes 57
 User List 43, 150
 User Management 336
 User Preferences 31

Userlist 322

- V -

version mismatch 22
 Vertical 289
 Video Tutorials 31, 38
 View 176, 273
 View a Follow Up Note 187
 View CallFlow 28
 View Follow Up note 30
 View Menu 37
 View Message 28, 33
 View Reminders 30
 Viewing Attachments 115
 Viewing Message Receipts 111
 Viewing Phone Messages (Incoming) 106
 Viewing Phone Messages (Outgoing) 108
 Viewing Text Messages 110
 Voice Announcements 243

- W -

Wait for network connection on startup 353
 Welcome Screen 25, 37
 What's New 31
 WhereRU 35, 314
 width of columns 47
 Windows Startup 219, 353
 Workstation Config 326, 353
 Workstation Configuration 18
 Workstation Service Center 334
 Workstation Setup 349
 Workstation Updates 346
 WorkstationConfig 18, 326
 WorkstationConfig.exe 18
 www.myphonepad.com 346, 349

- Y -

Your License Information 38



Copyright © 2026 Cybercom Software